

PLANMECA



Planmeca Compact™ i Classic

user's manual

The manufacturer, assembler and importer are responsible for the safety, reliability and performance of the unit only if:

- installation, calibration, modification and repairs are carried out by qualified authorised personnel
- electrical installations are carried out according to the appropriate requirements such as IEC 60364
- equipment is used according to the operating instructions.

Planmecca pursues a policy of continual product development. Although every effort is made to produce up-to-date product documentation this publication should not be regarded as an infallible guide to current specifications. We reserve the right to make changes without prior notice.

COPYRIGHT PLANMECCA

Publication number 30031240 Revision 15

Released 12 September 2025

Table of contents

1	Introduction.....	1
1.1	Intended use.....	1
1.1.1	Indications for use.....	1
1.1.2	Contraindications.....	1
1.1.3	Intended patient population.....	1
1.1.4	Intended users.....	2
1.2	Disclaimer.....	2
2	Associated documentation.....	3
3	Training.....	5
4	Registering your product.....	6
5	Annual maintenance.....	7
6	Symbols.....	8
6.1	Symbols on product labels.....	8
6.2	Symbols on package.....	10
7	For your safety.....	11
7.1	Safety precautions.....	11
7.2	Safety switches.....	16
7.3	Stopping chair movements quickly.....	18
7.4	Reporting serious incidents.....	18
8	MSO and ME Systems.....	19
9	Planmeca Compact i dental unit.....	20
9.1	Unit configuration.....	20
9.1.1	Over-the-patient delivery with balanced instrument arms.....	20
9.1.2	Over-the-patient delivery with hanging-tube instruments.....	22
9.1.3	Side delivery with hanging-tube instruments.....	23
9.2	Bowl.....	23
9.3	Monitor.....	25
9.4	USB connectivity.....	25
9.4.1	Instrument console.....	25
9.4.2	Cuspidor.....	26
9.5	Water and air quick-connectors.....	26
9.6	Planmeca Romexis connection.....	27
9.7	Planmeca ProX X-ray unit.....	28
9.8	Planmeca intraoral scanner.....	28
10	Planmeca Solanna and Planmeca Solanna Vision operating lights.....	30
11	Instrument system.....	31
11.1	Delivery arms.....	31
11.1.1	Over-the-Patient (OP) delivery arm.....	31
11.1.2	Side delivery arm.....	32
11.2	Instrument console.....	33
11.2.1	Instrument console with balanced instrument arms.....	33
11.2.2	Instrument console with hanging-tube instruments.....	35
11.3	Quick-connector hoses.....	35

11.4	Instrument functions.....	37
11.4.1	Instrument spray.....	38
11.4.2	Automatic chip blow.....	38
11.4.3	Instrument light.....	38
11.4.4	Reverse rotation of micromotor.....	38
11.4.5	Quickstart of air driven instruments.....	38
11.4.6	Instrument speed/power limit.....	38
11.4.7	Torque limit.....	39
11.4.8	Apical action.....	39
11.5	Trays.....	39
11.5.1	Quick-connect tray.....	39
11.5.2	Integrated tray.....	40
11.5.3	Top tray.....	41
11.5.4	Rotating tray.....	42
11.5.5	Double tray.....	42
11.5.6	Column tray.....	42
11.5.7	Cuspidor tray.....	43
11.6	Sterile water system.....	44
11.6.1	Introduction.....	44
11.6.2	Setting up sterile water system.....	46
11.6.3	Extending sterile water tube.....	48
11.6.4	Adjusting sterile water flow rate.....	49
11.6.5	Adjusting sterile water volume.....	50
11.6.6	Removing sterile water bag holder (OP deliveries).....	50
12	Suction system.....	51
12.1	Suction arms.....	51
12.1.1	Adjustable suction arm.....	51
12.1.2	Adjustable suction arm with Flexy holder.....	51
12.1.3	Left/right suction arm with Flexy holder.....	52
12.1.4	Chair-mounted adjustable suction arm with Flexy holder.....	52
12.1.5	Chair-mounted left/right suction arm with Flexy holder.....	53
12.2	Flexy holder.....	54
12.3	Removing and replacing suction tubes.....	56
13	Patient chair.....	58
13.1	Patient recognition.....	58
13.2	Automatic legrest.....	59
13.3	Trendelenburg position.....	60
13.4	Armrests.....	60
13.5	Headrest.....	61
13.5.1	Adjusting height of headrest.....	62
13.5.2	Adjusting headrest angle.....	63
13.5.3	Adjusting headrest for children or short patients.....	64
14	Control panel.....	68
14.1	Control panel on instrument console.....	68
14.1.1	Touchpad functionality.....	69
14.2	Control panel on Flexy holder.....	71
15	Foot control.....	72
15.1	Introduction.....	72
15.2	Foot control pedal.....	73
15.3	Foot control functions.....	74
15.3.1	Centre knob functions.....	74
15.3.2	Left-side and right-side knob functions.....	74
15.3.3	Pedal functions.....	74

15.4	Disconnecting standard foot control from dental unit.....	75
15.5	Wireless foot control.....	76
16	Switching unit on and off.....	78
17	Signing in and out.....	79
17.1	Signing in.....	79
17.2	Signing out.....	81
18	Managing users and personal settings.....	82
18.1	Introduction.....	82
18.2	Creating new user.....	82
18.3	Deleting user.....	83
18.4	Editing user settings.....	84
18.4.1	Editing user name.....	85
18.4.2	Editing language.....	86
18.4.3	Editing colour theme.....	88
18.5	Resetting personal settings.....	89
19	Assigning PlanID card to user.....	90
20	Checking dental unit details.....	93
20.1	About this unit.....	93
20.2	Unit type.....	94
20.3	Unit serial number.....	94
20.4	Unit software version.....	94
20.5	Service.....	94
20.5.1	Service contact details.....	94
20.5.2	Annual maintenance.....	94
20.5.3	Storage information.....	94
20.5.4	GUI diagnostics.....	95
20.5.5	PlanID.....	95
20.5.6	Clock calibration.....	95
20.5.7	Product registration.....	95
20.5.8	Peripherals.....	95
20.5.9	Dental unit model.....	95
20.5.10	Screensaver.....	95
20.6	Network settings.....	95
20.7	Message history.....	96
20.8	Bluetooth.....	96
20.9	Licences.....	96
21	Operating patient chair.....	97
21.1	Manual operation.....	97
21.2	Automatic operation.....	99
21.2.1	Overview.....	99
21.2.2	Extended vs. traditional view.....	100
21.2.3	Selecting automatic position.....	100
21.2.4	Selecting rinsing position.....	102
21.2.5	Stopping chair movements.....	103
22	Operating dental unit.....	104
22.1	Language.....	104
22.2	Bowl rinse.....	105
22.3	Cup fill.....	105
22.4	Timer.....	106
22.5	Door open / assistant call.....	107
22.6	Planmeca Solanna and Planmeca Solanna Vision operating light.....	108
22.6.1	Indicator lights.....	108

22.6.2	Switching operating light on/off.....	110
22.6.3	Switching composite mode on/off.....	111
22.6.4	Adjusting intensity of operating light.....	112
22.6.5	Adjusting intensity of operating light in composite mode.....	114
22.6.6	Changing light tone of operating light.....	115
22.7	Planmeca Solanna Vision camera.....	116
22.7.1	Starting to use cameras.....	117
22.7.1.1	Activating camera from Planmeca Romexis.....	117
22.7.1.2	Activating camera from dental unit.....	118
22.7.2	Adjusting camera settings from dental unit.....	119
22.7.2.1	Selecting camera and zoom level.....	119
22.7.2.2	Adjusting video settings.....	120
22.7.3	Switching video streaming on/off.....	122
22.7.4	Recording video.....	123
22.7.5	Capturing image.....	124
22.8	X-ray film viewer.....	124
23	Operating instruments.....	125
23.1	Instrument logic.....	125
23.2	Micromotor.....	126
23.2.1	Speed/power.....	126
23.2.2	Reverse rotation.....	127
23.2.3	Speed/power limit.....	127
23.2.4	Instrument spray.....	127
23.2.5	Momentary spray.....	129
23.2.6	Automatic chip blow.....	129
23.2.7	Manual chip blow.....	129
23.2.8	Instrument light.....	130
23.3	Bien-Air MCX and KaVo KL703 LED micromotors.....	131
23.3.1	Torque.....	131
23.3.2	RPM.....	132
23.4	Bien-Air MX2 Plus and KaVo KL703 LED with endo micromotors.....	132
23.4.1	Torque.....	133
23.4.2	RPM.....	134
23.4.3	Presets.....	134
23.5	Bien-Air MX-i micromotor.....	138
23.5.1	Sterile water.....	138
23.5.2	Torque.....	139
23.5.3	RPM.....	139
23.5.4	Presets.....	139
23.6	Morita TORX micromotor.....	140
23.6.1	Torque.....	140
23.6.2	RPM.....	142
23.6.3	Apical action.....	142
23.6.4	Presets.....	144
23.7	Apex locator.....	146
23.7.1	Before using apex locator.....	147
23.7.2	Using apex locator.....	150
23.7.3	Testing apex locator function.....	152
23.8	Turbine.....	154
23.8.1	Speed/power.....	155
23.8.2	Quickstart.....	155
23.8.3	Instrument spray.....	155
23.8.4	Speed/power limit.....	157
23.8.5	Momentary spray.....	157

23.8.6	Automatic chip blow.....	158
23.8.7	Manual chip blow.....	158
23.8.8	Instrument light.....	158
23.9	Scaler.....	159
23.9.1	Speed/power.....	159
23.9.2	Instrument spray.....	159
23.9.3	Momentary spray.....	161
23.9.4	Satelec Newtron scaler.....	161
23.9.5	LM scaler.....	162
23.9.6	Planmeca Piezon LED (EMS) scaler.....	162
23.9.7	Instrument light.....	163
23.10	Planmeca Lumion Plus polymerisation light.....	163
23.11	Intraoral camera and Planmeca Romexis.....	164
23.11.1	Intraoral camera placed in instrument console.....	165
23.11.2	Intraoral camera placed in suction holder.....	167
23.12	Planmeca intraoral scanner.....	169
23.12.1	Operating intraoral scanner from foot control.....	170
24	Operating suction handpieces.....	172
24.1	Saliva and high-volume suction.....	172
24.2	Tilting high-volume suction.....	173
25	Programming.....	174
25.1	Introduction.....	174
25.2	Organising items on control panel.....	175
25.3	Automatic chair positions.....	175
25.3.1	Extended view.....	176
25.3.2	Traditional view.....	177
25.4	Instrument settings.....	178
25.4.1	Instrument speed/power limit.....	178
25.4.2	Instrument spray.....	178
25.4.3	Enabling/disabling sterile water mode.....	179
25.4.4	Automatic chip blow.....	180
25.4.5	Instrument light.....	180
25.4.6	Bien-Air MCX and KaVo KL703 LED micromotors.....	181
25.4.7	Bien-Air MX2 Plus and KaVo KL703 LED with endo micromotors.....	183
25.4.7.1	Modifying preset values.....	183
25.4.7.2	Saving modified preset values.....	185
25.4.8	Bien-Air MX-i micromotor.....	186
25.4.8.1	Modifying preset values.....	186
25.4.8.2	Saving modified preset values.....	187
25.4.9	Morita TORX micromotor.....	188
25.4.9.1	Modifying preset values.....	188
25.4.9.2	Saving modified preset values.....	190
25.4.10	Planmeca Lumion Plus polymerisation light.....	191
25.5	Timer settings.....	191
25.6	Bowl rinse and cup fill.....	192
25.6.1	Adjusting cup fill and bowl rinse flow rates.....	192
25.6.2	Duration of bowl rinsing.....	193
25.6.3	Duration of cup filling.....	193
25.7	Planmeca Solanna and Planmeca Solanna Vision operating lights.....	194
25.7.1	Intensity.....	194
25.7.2	Colour temperature and brightness.....	195
25.7.3	Gesture sensor.....	196
25.8	Duration of door open / assistant call.....	197

25.9	Clock.....	198
25.10	Date.....	199
25.11	Wireless foot control.....	200
25.11.1	Pairing wireless foot control.....	200
25.11.2	Viewing battery charging information.....	202
25.11.3	Adjusting radio settings.....	202
26	Calibrating clock.....	204
27	Flushing and cleaning programs.....	206
27.1	When to use cleaning programs.....	206
27.2	Before you start.....	206
27.3	Short instrument flushing.....	209
27.4	Long instrument flushing.....	212
27.5	Suction cleaning.....	214
27.6	Waterline cleaning.....	217
27.6.1	Introduction.....	217
27.6.2	Starting waterline cleaning cycle.....	218
27.6.3	Waterline flushing.....	224
27.6.4	Maintenance.....	228
28	Cleaning and disinfection.....	229
28.1	Introduction.....	229
28.2	Dental unit surfaces.....	229
28.3	Instruments.....	232
28.4	Instrument console.....	233
28.4.1	Oil collector.....	233
28.5	Cuspidor.....	233
28.5.1	Bowl.....	233
28.5.2	Instrument flushing holder.....	235
28.5.3	Suction tube cleaning holder.....	235
28.5.4	Disposable filters.....	236
28.5.5	Spittoon valve coarse filter.....	236
28.5.6	Amalgam collector.....	237
28.5.7	Deposit cup.....	238
28.5.8	Clean-water bottle.....	239
28.6	Suction system.....	239
28.6.1	In the morning.....	240
28.6.2	After each patient.....	240
28.6.3	After each working day.....	240
28.6.3.1	OroCup.....	241
28.6.4	Weekly cleaning procedures.....	242
28.6.4.1	During working day.....	242
28.6.4.2	After working day.....	243
28.6.5	Cleaning suction handpieces.....	243
28.7	Planmeca ProX.....	244
28.8	Planmeca ProSensor.....	244
28.9	Planmeca intraoral scanner.....	245
28.10	Cleaning external PC.....	245
29	Clean water system.....	246
29.1	Introduction.....	246
29.2	Waterline cleaning.....	247
29.2.1	After the working day.....	247
29.2.2	In the morning.....	250
30	Planmeca Patrol by BWT.....	252

30.1	Replacing Planmeca Patrol filter.....	252
31	Help and error messages.....	256
31.1	Overview.....	256
31.2	Viewing help and error message history.....	257
31.3	Help messages.....	259
31.4	Error messages.....	270
31.4.1	General error messages.....	270
31.4.2	Power supply related error messages.....	273
31.4.3	Control panel related error messages.....	275
31.4.4	Instrument related error messages.....	275
31.4.5	Instrument multiplexer related error messages.....	276
31.4.6	Suction holder related error messages.....	278
31.4.7	Foot control related error messages.....	279
31.4.8	Operating light related error messages.....	280
31.4.9	Separator system related error messages.....	280
31.4.10	Patient chair related error messages.....	281
31.4.11	MAIN CPU related error messages.....	282
31.4.12	Headrest related error messages.....	282
31.4.13	Water leak related error messages.....	283
31.4.14	Maintenance related errors.....	283
31.4.15	Software upgrade error messages.....	283
31.4.16	Error messages generated by control panel.....	284
32	Disposal.....	286
33	Technical information.....	287
33.1	Technical specifications.....	287
33.2	Detachable parts.....	290
33.3	Applied parts.....	296
33.4	Instrument classifications.....	297
33.5	Dimensions.....	298
33.5.1	Positioning of patient, dentist and assistant.....	298
33.5.2	Patient area.....	298
33.5.3	Over-the-patient delivery with balanced instrument arms.....	301
33.5.4	Over-the-patient delivery with hanging-tube instruments.....	303
33.5.5	Side delivery with hanging-tube instruments.....	305
33.6	Planmeca Compact i dental unit water consumption.....	306
34	Planmeca as EU importer.....	307
35	Certifications.....	308
35.1	CE.....	308
35.2	EU Declaration of Conformity for PlanID RFID-reader.....	308
35.3	EAC Declaration of Conformity for PlanID RFID-reader.....	308
35.4	FCC Class B Notice for wireless foot control.....	308
35.5	FCC Class B Notice for PlanID RFID-reader.....	308
35.6	Industry Canada (IC) Compliance Statement.....	309
35.7	Industrie Canada (IC) Déclaration de conformité.....	309
35.8	RF Exposure.....	309

1 Introduction

This manual describes the Planmeca dental unit and how to use it.

Depending on the configuration of your dental unit, this manual may contain parts that do not apply to your dental unit. Please read this manual carefully before using the unit.

NOTE

This manual is valid for software revision 7.13.0 or later.

NOTE

In error situations, this manual is the primary source of information.

NOTE

For information on OEM products, please refer to OEM documentation.



This Planmeca dental unit fulfils the requirements of Medical Device Regulation (EU) 2017/745, RoHS, REACH and WEEE.

BASIC UDI-DI (Global Model Number): 6430035420075R



All button illustrations indicate that the button on the control panel should be pressed. Pressing a button will either switch a function on or off, depending on the original setting, or change the value.

The settings and values shown in this manual are only examples and should not be interpreted as recommended values unless otherwise stated.

1.1 Intended use

Planmeca Compact i is a Planmeca dental unit. The system is intended for use in dental care medical operations. The system is to be used by authorised professionals within the scope of his/her education, training and experience.

The system provides the dental practitioner a motorised patient chair, dental instruments and suction system for removal of bodily fluids.

1.1.1 Indications for use

Dental care medical operations include evaluation, diagnosis, prevention and/or treatment of diseases, disorders and/or conditions of the oral cavity, maxillofacial area and/or the adjacent and associated structures and their impact on the human body.

1.1.2 Contraindications

There are no known contraindications other than the patient weight limit.

1.1.3 Intended patient population

Age	Both children and adults, no specific age limitations
Weight	Less than or equal to 185 kg + 15 kg accessories

1.1.4 Intended users

Intended healthcare user

Education Authorised professionals within the scope of his//her education, training and experience

Intended service user

Education Planmeca authorised dental unit service and maintenance professionals

1.2 Disclaimer

NOTE

IMPORTANT SAFETY NOTICE!

Planmeca Solanna Vision is equipped with a network connection. Planmeca claims no responsibility for the end user's data security or for any malfunction in the system that may lead to data loss. User organisation must take care of protecting the network by using a firewall.

NOTE

IMPORTANT DATA PRIVACY NOTICE!

Planmeca Solanna Vision is equipped with camera and microphone functionalities. These can be used to record patient and employee personal data. User organisation must take into account national regulations concerning the fundamental rights and freedoms of natural persons and in particular their right to the protection of personal data.

2 Associated documentation

This Planmeca dental unit is delivered with the following manuals and diagrams:

- User's manual
For dental care professionals. Describes the dental unit and its different parts as well as instructs how to operate and clean the dental unit.
- Installation manual
For service personnel. Describes how to install the dental unit.

NOTE

Use the installation template (included in delivery) to position the unit correctly.

- Technical manual
For service personnel. Gives instructions for service situations.
- Wiring diagrams (10030500)
- Pneumatic diagrams (30014222)
- Planmeca Compact i v2 / i3 / i5 / iSim electrical safety measurements according to IEC 62353 (D0011675 and D0011692)
For service personnel. Contains electrical safety measurements that must be performed after installation and electrical parts replacement, and during annual maintenance.
- User's manual for optional WEK water disinfection system
For dental care professionals. Gives instructions for use and maintenance.

Planmeca Romexis software is delivered with the following manuals:

- Planmeca Romexis user's manual
For dental care professionals. Describes how to monitor and control the activities as well as gather data related to dental treatments.
- Planmeca Romexis quick installation guide
For service personnel. Describes how to install Planmeca Romexis software.
- Planmeca Romexis technical manual
For service personnel. Gives instructions for service situations.

The Planmeca Solanna or Planmeca Solanna Vision operating light is delivered with the following manuals:

- User's manual
For dental care professionals. Describes the operating light and instructs how to operate and clean it.
- Installation and technical manual
For service personnel. Describes how to install the operating light to the ceiling or wall, and gives instructions for service situations.
The operating light's installation to the dental unit is described in the dental unit's installation manual.

The intraoral X-ray unit Planmeca ProX can be installed to the Planmeca dental unit. Planmeca ProX is delivered with the following manuals:

- User's manual
For dental/health care professionals. Describes the intraoral X-ray unit and its different parts as well as instructs how to operate and clean the X-ray unit.
- Installation manual
For service personnel. Describes how to install the intraoral X-ray unit.
- Technical manual
For service personnel. Gives instructions for service situations.

The Planmeca intraoral scanner is delivered with the following manuals:

- Planmeca FIT user's manual
For dental care professionals who take digital impressions for dental restorations.
- Planmeca FIT installation manual
For service personnel. Describes how to install the intraoral scanner.

The Planmeca ProSensor sensor is delivered with the following manuals:

- User's manual
For dental care professionals. Describes the sensor that is intended to be used for capturing digital intraoral X-ray images and instructs how to use it.
- Installation manual
For service personnel. Describes how to install the sensor.

The user's manuals are also available in the Planmeca [Material bank](#) > Manuals > Dental units.

The installation and technical manuals are also available in [Planmeca One](#) > Documents and downloads > Documents.

Before using surface disinfectants, upholstery disinfectants, dental unit water and waterline disinfectants, or suction disinfectants, read the disinfectant's material safety data sheet and the document *Planmeca approved disinfectants* (30007097). The document can be found in the Planmeca [Material bank](#).

Before using an instrument, read the instrument's user's manual.

For a full list of accessories, refer to the Planmeca product price list.

3 Training

A hands-on user's training is given in connection with the installation of this device.

4 Registering your product

About this task

Before you start using your Planmeca product, you must register it to activate the warranty.

NOTE

As an alternative to navigating to the registration website as described below, you can enter www.planmeca.com/register/ in your Internet browser.

Steps

1. Go to Planmeca's Product registration page.

- 1.a. Sign in to the dental unit.

- 1.b. Press **Program**.



- 1.c. Press **About this unit**.



- 1.d. Select **Service > Product registration**.

- 1.e. Read the QR code with a QR code reader to enter the registration website.

2. Follow the instructions on the website.

5 Annual maintenance

To guarantee the dental unit's proper operation, the unit must be checked and serviced by a qualified Planmeca service technician according to the maintenance schedule that has been set for your dental unit.

The expected service life of this Planmeca dental unit as defined in standard IEC 60601-1 is 10 years.

In the annual maintenance, the service technician replaces all parts specified by the maintenance kit. These include, but are not limited to, parts in contact with air, water and suction systems. In addition, the service technician checks and services all dental unit parts suspect to wear and tear in normal use. These include parts in the cuspidor, foot control, instrument console, delivery arms, patient chair, suction arm and operating light. Also, the mechanical stability and electrical safety inspection is performed.

The default maintenance interval is 365 days.

In the *About this unit* window you can check when the annual maintenance was last performed and when it should be performed next.

A notification will remind you about the annual maintenance well in advance.

6 Symbols

6.1 Symbols on product labels



Fulfils the requirements of Medical Device Regulation (EU) 2017/745.



Certification mark of the Eurasian Customs Union.



SGS listing marking according to US and Canadian standards (ANSI/AAMI ES60601-1 and CAN/CSA C22.2 No. 60601- 1).



Manufacturer (Standard ISO 15223-1).



Date of manufacture (Standard ISO 15223-1).



Serial number (Standard ISO 15223-1).



Medical Device (Standard ISO 15223-1).



Type B applied part (Standard IEC 60417).



Type BF applied part for specified dental instruments (Standard IEC 60417).



On/Off switch (Standard IEC 60417).



Alternating current (Standard IEC 60417).



Consult electronic instructions for use (Standard ISO 15223-1).



Refer to instruction manual/booklet (Standard ISO 7010).



General warning (Standard ISO 7010).



Warning, crushing hazard: hand (Standard ISO 7010).



Warning, hot surface (Standard ISO 7010).



Warning: Electricity (Standard ISO 7010).

To avoid risk of electric shock, this equipment must only be connected to a supply mains with protective earth.



Health hazard (acc. to EC regulation no. 1272/2008).



Do not put fingers inside mechanical parts.



Strong magnet. Remove the tray mounting arm when treating patients who have a cardiac pacemaker. (Standard ISO 7010.)



Safe working load and total mobile equipment mass.

IPX1

Protected against dripping water (Standard IEC 60529).



Disposable item. Do not reuse (Standard ISO 15223-1).



Sterilised using steam or dry heat (Standard ISO 15223-1).

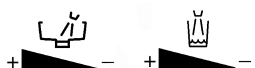

Indicates the direction of rotation for increasing/ decreasing the water flow for the bowl rinse and cup fill. (Standard ISO 7000.)



Separate collection for electrical and electronic equipment according to Directive 2012/19/EU (WEEE).



Protective earth (Standard IEC 60417).



Radio certification label (Japanese Radio Law).

Note that the mains voltage is always present at the mains terminal under the cover, when the unit is switched on. Do NOT open the cover. (Standard IEC 60601-1.)

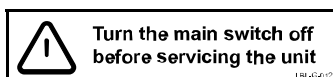

6.2 Symbols on package



Stack height



This way up (Standard ISO 7000).



Fragile; handle with care (Standard ISO 15223-1).



Keep dry (Standard ISO 15223-1).



Temperature limit (Standard ISO 15223-1).



Humidity limitation (Standard ISO 15223-1).



Atmospheric pressure limitation (Standard ISO 15223-1).



General symbol for recovery/recyclable (Standard ISO 7000).

7 For your safety

7.1 Safety precautions

**WARNING**

No modification of this dental unit is allowed.

**WARNING**

Only instruments or equipment approved by Planmeca may be connected to this dental unit.

**WARNING**

Do not simultaneously touch the patient and the PC.

**WARNING**

Do not simultaneously touch the patient and the USB ports, or any electrical connectors of external instrument modules.

**WARNING**

Do not touch the patient when opening the cuspidor door or when the cuspidor door is open.

**WARNING**

Applies only to Planmeca dental units without a patient chair
Do not lift the patient when the patient is placed under the delivery arm. Risk of trapping!

**WARNING**

Maintenance procedures shall not be performed while equipment is in use with a patient.

**WARNING**

The patient must not be in contact with instruments when the patient is resuscitated with a defibrillator.



WARNING

The worm screw securing nut (1) in the chair lift motor must always be attached to the worm screw and must not be removed. If the securing nut is faulty or displaced, immediately stop using the dental unit and contact your Planmeca dealer.



CAUTION

A faulty or broken dental unit must not be used.

CAUTION

Do not perform other maintenance procedures than those instructed in this manual.

CAUTION

When servicing the unit, always switch the unit off.

CAUTION

Do not connect a multiple portable socket-outlet or extension cord to the system.

CAUTION

Guide the patient to sit on the chair. Make sure no one sits on the legrest, the backrest or any other part of the dental unit.

CAUTION

When the patient is in the chair, ensure that the patient's arms and legs are resting on the chair.

CAUTION

Do not allow the patient to grab the operating light or its arm when getting seated or getting up from the patient chair.

CAUTION

Instrument hoses have a limited lifespan and should be replaced after 5 years of use.

CAUTION

Drops of water on the touch display might disturb the functioning of the control panel.

CAUTION

Lock the control panel from the Maintenance window before using a table-top instrument.

CAUTION

As Planmeca supplies two types of power supply for the wireless foot control, check the label on the power supply to ensure whether the battery can be charged while treating a patient.

CAUTION

The dental unit must not be used simultaneously with the intraoral X-ray unit Planmeca ProX.

CAUTION

The light source of the operating light may cause retinal injury if viewed upon directly.

Protect the patient's and dental treatment staff's eyes with protective glasses that block high-energy visible light (HEV light), or limit the direct exposure to 4 minutes.

CAUTION

Switch off the unit before using an electrosurgical knife.

CAUTION

The use of the electrosurgical knife may affect the function of an implanted pacemaker or defibrillator. Please refer to the manufacturer's own documentation.

CAUTION

Do not use the scaler or the polymerisation light on patients with cardiac pacemakers. The instrument can cause disturbance on the pacemaker's function.

CAUTION

Electromagnetic interference between the equipment and other devices can occur in very extreme conditions. Do not use the equipment in close conjunction with sensitive devices, or devices creating high electromagnetic disturbances.

CAUTION

Do not use the equipment in close conjunction with anaesthetic gas or in highly oxygenated environments (oxygen content >25%).

CAUTION

Before using the dental unit, ensure that the instruments have been properly flushed and that the suction tubes as well as the dental unit's waterlines have been cleaned as instructed in this manual.

CAUTION

If the drain is blocked, the dental unit might overflow with contaminated water and excessive water could flow onto the floor. Shut down the unit and contact your property's caretaker and your Planmeca dealer.

CAUTION

When a water leak is detected, error E90 is displayed. Turn off the clinic's main water tap and contact your Planmeca dealer.

CAUTION

For surgical procedures, use sterile irrigating solutions, such as sterile water or saline. Appropriate delivery devices should be used to deliver sterile irrigating solutions during surgery. This may include a dedicated surgical irrigation system with components including handpieces that are single-use disposable or compatible with heat sterilisation methods used in outpatient dental settings.

CAUTION

A power cut will shut down the software-controlled backflow prevention system. If you are using a turbine without a built-in backflow prevention system, contaminated water can enter into the turbine and turbine hose in the event of a power cut.

CAUTION

In extreme operating conditions the temperature of the chair lift and backrest motors might rise significantly. **DO NOT TOUCH THE MOTORS!**

CAUTION

In extreme operating conditions the surface temperature of the seat upholstery may rise to 44°C (111°F). When applying maximum allowed load on the patient chair in hot climate conditions, ensure sufficient time for the seat upholstery to cool down.

NOTE

Before switching on the dental unit, make sure that the main water feed, air pressure and suction motor are turned on.

NOTE

National regulations concerning the quality of dental water and dental air must be followed when using the Planmeca dental unit.

NOTE

The water used by the dental unit instruments and cup fill are to be used for rinsing only. For more information, please contact your Planmeca dealer.

NOTE

The main water feed must be turned off when the dental unit is not in use.

NOTE

If your dental unit is not equipped with an internal water/waterline cleaning system, you must connect the dental unit to an external water/waterline cleaning system.

NOTE

The user must monitor the microbial load of the water used by the dental unit.

NOTE

If using air abrasives with the air polisher, please consult instructions for use given by the air polisher manufacturer. Make sure that adequate flushing of dental unit is performed immediately after using air polishers.

NOTE

The air used by the dental unit instruments must be dry, clean and oil-free.

NOTE

Never place heavy objects or containers of liquid on any part of the unit or hang objects from the unit's arm structures.

NOTE

Care should be taken when other movable equipment is used in conjunction with the dental unit.

NOTE

The dental unit shall only be connected to a trusted private network (and not, for example, the Internet).

NOTE

EMC requirements have to be considered, and the equipment must be installed and put into service according to the specific EMC information provided in the accompanying documents.

NOTE

Portable and mobile RF communications equipment can affect the dental unit.

NOTE

External equipment intended for connection to signal input, signal output or other connectors, shall comply with relevant IEC standard (e.g. IEC 60950 for IT equipment and the IEC 60601 series for medical electrical equipment). In addition, all such combinations - systems - shall comply with the IEC 60601-1 standard. Equipment not complying to IEC 60601-1 shall be kept outside the patient area.

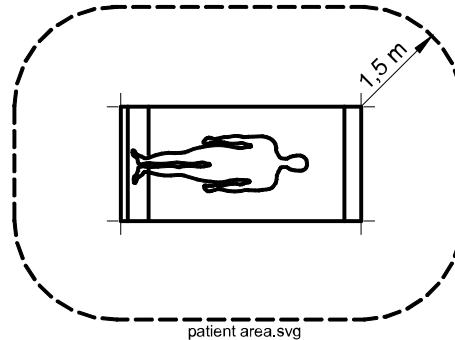

Any person who connects external equipment to signal input, signal output or other connectors has formed a system and is therefore responsible for the system to comply with the requirements of IEC 60601-1. If in doubt, contact a qualified technician or your local representative.

7.2 Safety switches

Care should be taken when driving the patient chair from one position to another. Obstructions in the patient chair's line of movement activate safety switches that stop the motorised movements. The safety switches and their functions are described below.

1. Backrest

An obstruction between the backrest and the floor when driving down the chair and/or the backrest stops downwards chair and backrest movements. Remove the obstruction to resume normal operation.

2. Chair-mounted left/right suction arm, joint

The suction arm is in the upmost position and prevents the chair and backrest from being driven downward. They can be driven normally when the suction arm has been moved downward.

3. Chair-mounted left/right suction arm, arm underside

An obstruction under the suction arm prevents the chair and backrest from being driven downward. Remove the obstruction to resume normal operation.

4. Chair bottom and lift adapter

An obstruction between the chair and the floor stops downwards chair and backrest movements. Remove the obstruction to resume normal operation.

5. Legrest

The position of the legrest is identified as 'locked' or 'unlocked' (= hangs freely). Based on this information, the chair can be driven lower when it is locked.

6. Adjustable legrest (all lengths)

An obstruction between the legrest and the floor stops downward chair movements. Remove the obstruction to resume normal operation.

7. Bowl

The bowl is above the patient chair and stops upward chair movements. Move the bowl into home position to resume normal operation.

8. Cuspidor door

The patient chair up/down movement is inhibited when the cuspidor door is open. Also, the operation of instruments is inhibited. Close the door to resume normal operation.

9. Side delivery; delivery arm joint (down)

The delivery arm is below its mechanical limit and downward backrest movements are stopped. After stopping, the backrest can be driven upward.

10. Side delivery; delivery arm joint (up)

The delivery arm is above its mechanical limit and upward backrest movements are stopped. After stopping, the backrest can be driven downward.

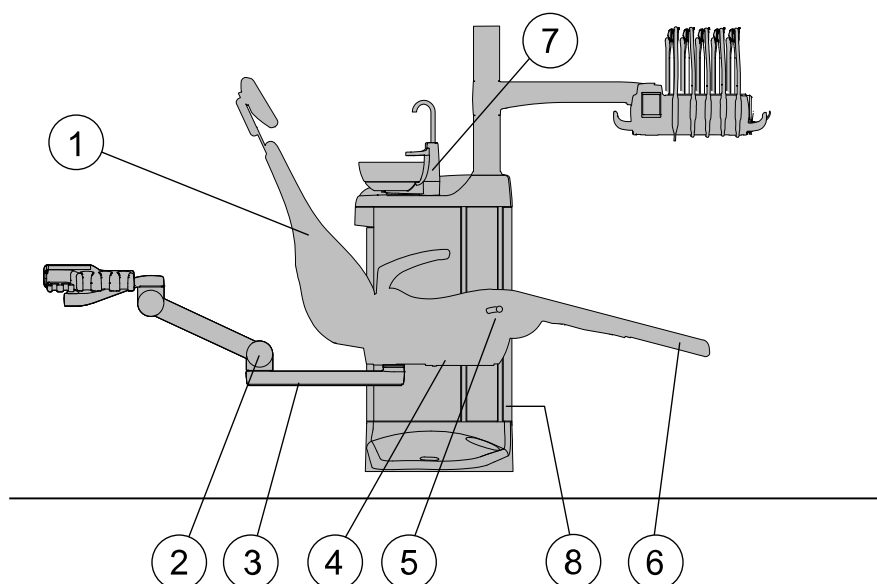

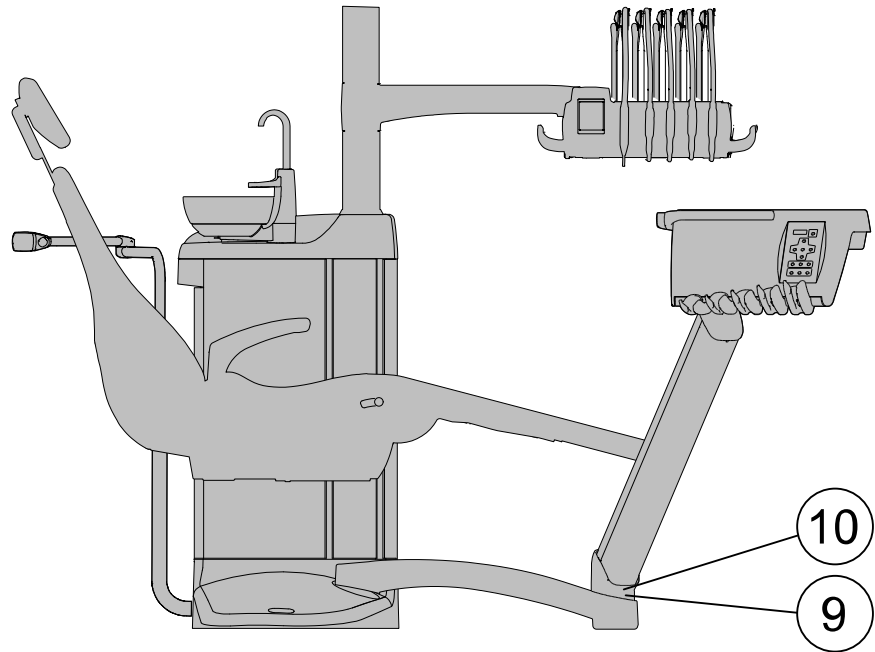

7.3 Stopping chair movements quickly

The chair movements can be stopped quickly by:

- touching anywhere on the control panel display,
- kicking safety switch number 4 on the chair bottom,
- pushing the foot control pedal or the centre knob in any direction, or by
- pressing the handle of the foot control.

NOTE

If the wireless foot control has been idle for 2 hours and has gone to sleep mode, you must press the handle twice to stop the chair movements. (The first press wakes the foot control up from sleep mode and the second press stops the movements.)

7.4 Reporting serious incidents

Serious incidents that have occurred in relation to the equipment must be reported to the manufacturer and the local competent authority.

8 MSO and ME Systems

Optionally, the Planmeca Compact i dental unit is equipped with a Multiple Socket Outlet (MSO). When Planmeca Compact i and some other medical device are inter-connected by the use of an MSO, the combination is recognised as a Medical Electrical System (ME System). ME Systems have a whole set of requirements and restrictions to consider. The rules given below help to maintain patient/operator safety and ensure compliance with the medical device regulation.

- Only Planmeca recognised devices may be connected to Planmeca Compact i. Otherwise, the organisation making the inter-connection between Planmeca Compact i and the other device becomes the responsible manufacturer of the ME System and is responsible for the SYSTEM to comply with IEC 60601-1:ed3.2 (or later edition).
- Only one device may be connected to the MSO at a time.
- Only the device forming the ME System may be powered from the MSO.
- The device connected to the MSO shall meet safety requirements set in the standard IEC 60601-1 edition 3.1 or later.
- The maximum allowed load power is 300 VA.
- The connected device shall not feed power to Planmeca Compact i.
- The maximum cord length of the device is 1.5 m and the minimum wire cross section is 1.5 mm².
- It is absolutely forbidden to connect an extension cord or additional MSOs to the Planmeca Compact i MSO.
- The cord shall be inspected before connection and use. A cord showing any marks of damage shall be replaced with an intact cord.
- Contact your local Planmeca dealer for service if the MSO is damaged or becomes loose.
- To separate the other device from the mains, disconnect the cord from the MSO.
- Never connect the cord to the MSO when the other end of the cord is detached from the device.

If given rules are not followed, patient/operator safety may be compromised and the risk of electric shock is substantially increased. All devices connected with a cord having a maximum length of 1.5 m are within the patient area and are considered as medical equipment.

9 Planmeca Compact i dental unit

9.1 Unit configuration

9.1.1 Over-the-patient delivery with balanced instrument arms

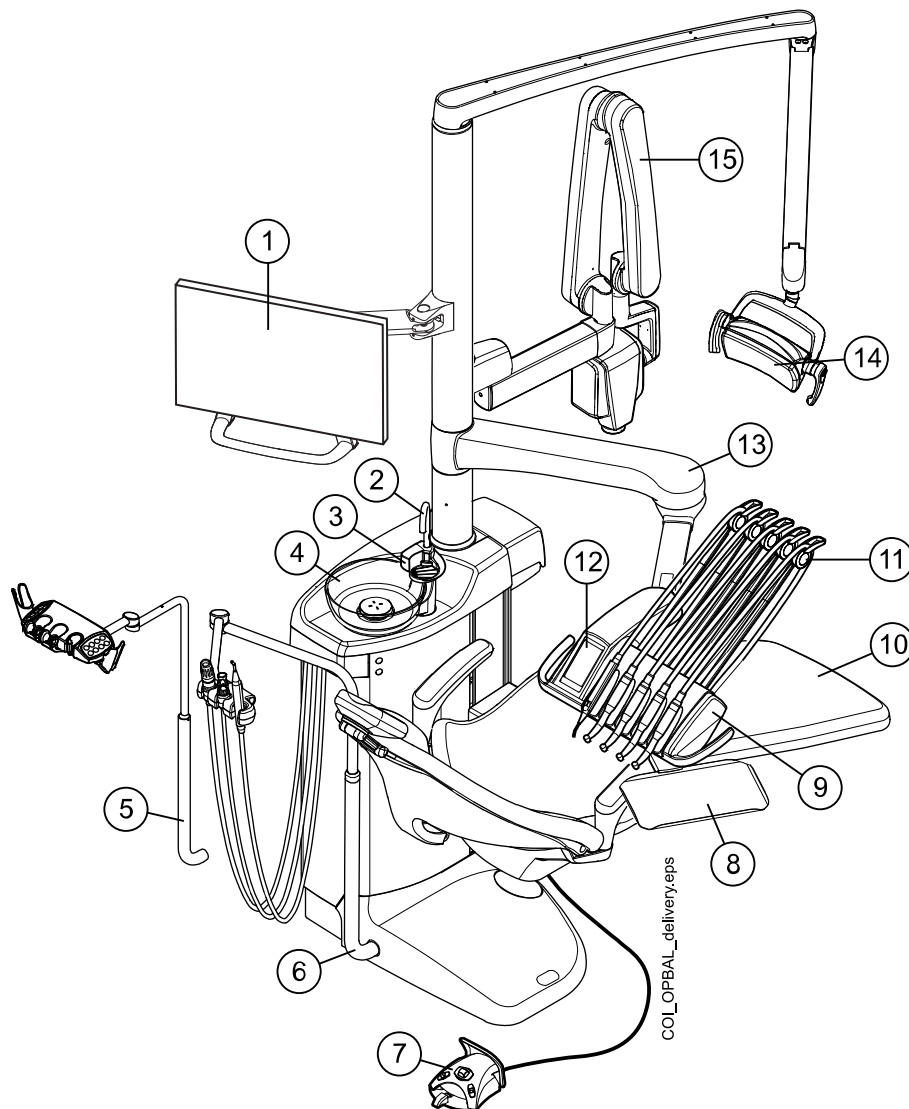

1. Monitor	6. Adjustable suction arm	11. Balanced instrument arms
2. Cup fill tube	7. Foot control	12. Control panel
3. Bowl rinse tube	8. Tray	13. OP delivery arm 520 mm
4. Bowl	9. Instrument console	14. Operating light
5. Adjustable suction arm with Flexy holder	10. Patient chair	15. ProX X-ray unit

This type of dental unit configuration has the option of a shorter OP delivery arm (340 mm). The shortened console arm (1) allows easy access to the patient chair if the instrument console is placed on the assistant's side during patient change. The shortened console arm is especially well suited for dental units without bowl.

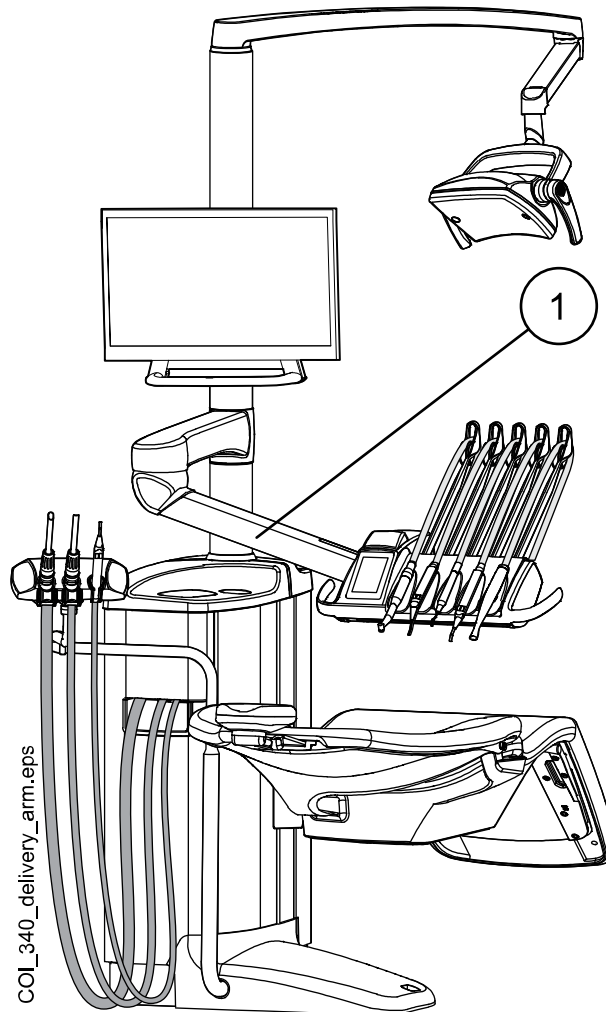

9.1.2 Over-the-patient delivery with hanging-tube instruments

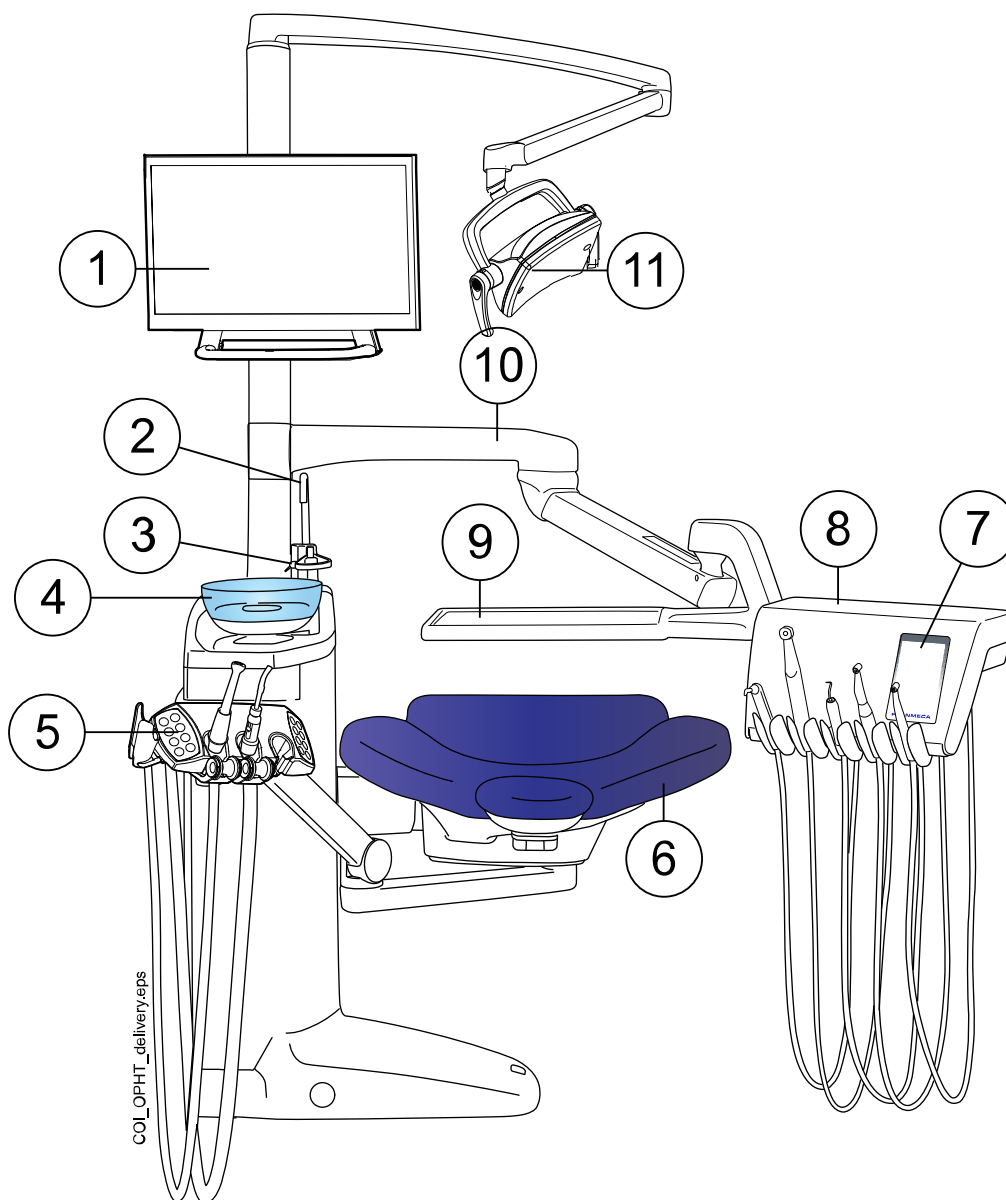

COI_OPHT_delivery.eps

1. Monitor	7. Control panel
2. Cup fill tube	8. Instrument console with hanging-tube (HT) instruments
3. Bowl rinse tube	9. Tray
4. Bowl	10. OP delivery arm
5. Chair-mounted left-right suction arm with Flexy holder	11. Operating light
6. Patient chair	

9.1.3 Side delivery with hanging-tube instruments

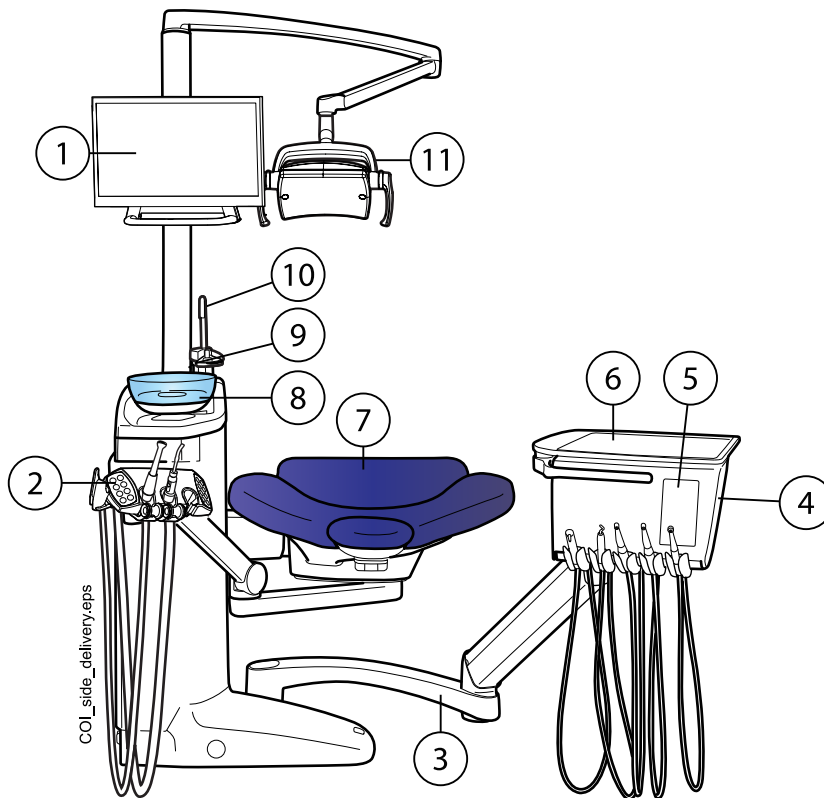

1. Monitor	7. Patient chair
2. Chair-mounted left-right suction arm with Flexy holder	8. Bowl
3. Side delivery arm	9. Bowl rinse tube
4. Instrument console with hanging-tube (HT) instruments	10. Cup fill tube
5. Control panel	11. Operating light
6. Tray	

9.2 Bowl

CAUTION

Do not allow the patient to grab the bowl when getting seated or getting up from the patient chair.

NOTE

Always place the bowl in home position.

NOTE

Make sure that the bowl is not above the patient chair when you drive the chair upward.

The glass bowl is attached to the top of the cuspidor.

It can be rotated 110° around its axis according to the figure below.

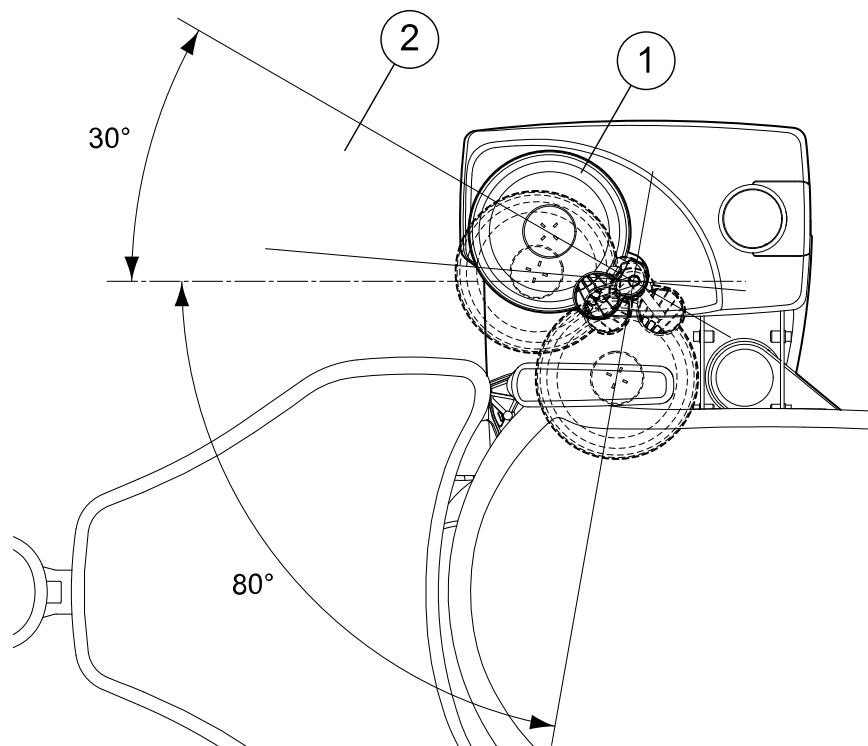

- 1 Home position
- 2 To avoid a collision between the patient chair and the bowl when driving the chair upward, position the bowl within this area.

If the bowl assembly for some reason comes off the cuspidor, you can put it back as follows:

1. Place the ring to the underside of the bowl assembly
This is shown by item 1 in the picture below.
2. Make sure that the peg goes into the slot as shown in the picture below.

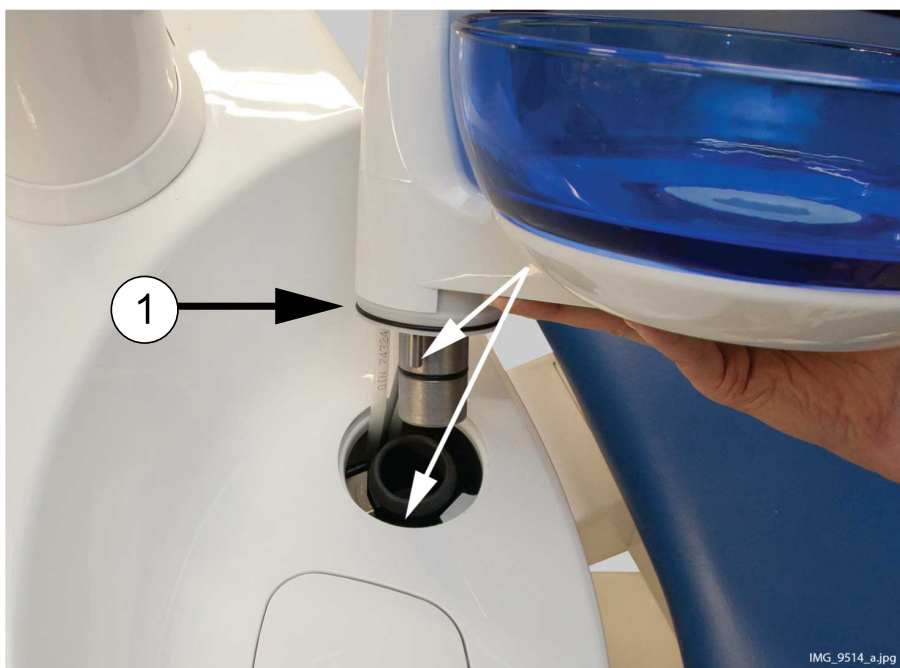

3. Push the bowl downwards at the same time making sure that no cables are squeezed.
4. Turn the bowl assembly into place. You will know that it is in place when you hear the clicking sound of the micro switch

9.3 Monitor

The monitor can be moved from its handle.

CAUTION

Do not allow the patient to grab the monitor handle or monitor arm when getting seated or getting up from the patient chair.

NOTE

Never spray water on the monitor.

Refer also to OEM documentation delivered with the monitor.

9.4 USB connectivity

9.4.1 Instrument console

The USB port on the underside of the instrument console offers a USB connection for the dentist's intraoral camera.

NOTE

Connect only intraoral cameras supplied by Planmeca to the USB port.

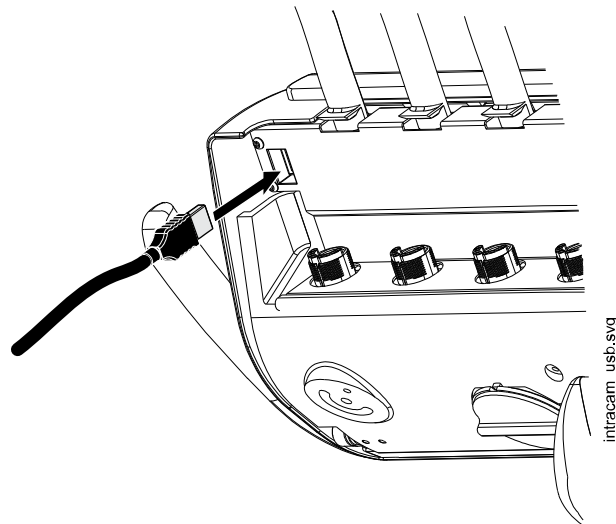

9.4.2 Cuspidor

There are two optional USB ports on the cuspidor.

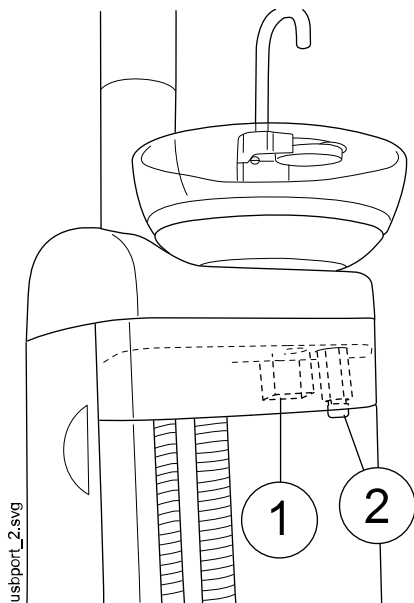

1. USB port for charging
2. USB port for connecting the intraoral camera.

Connect only intraoral cameras supplied by Planmeca to the USB port.

9.5 Water and air quick-connectors

The water and air quick-connectors can be used with external devices. When you connect a device to the quick-connector, water/air flows to the device.

The water and air quick-connectors are located on the cuspidor, next to the suction hoses.

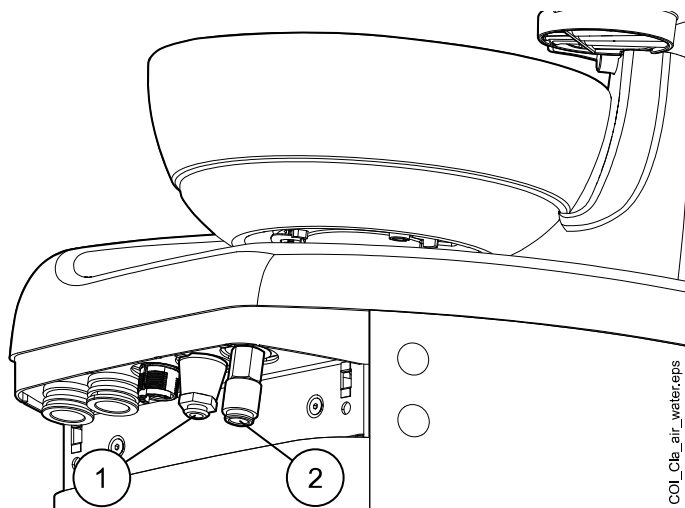

- 1 Water quick-connector
- 2 Air quick-connector



To avoid stagnant water inside the dental unit, regularly use enough water with external devices connected to the water quick-connector, as the quick-connector's waterline is not included in the dental unit's flushing and cleaning programs.

9.6 Planmeca Romexis connection

The dental unit must be connected to Planmeca Romexis software when you want to use Planmeca Romexis Clinic Management, the intraoral camera, the intraoral scanner, the touchpad functionality, or sign in with a PlanID card.

Planmeca Romexis Clinic Management software allows time stamped recording and real-time monitoring and control of most dental unit activities. The features and gathered data can be used for remote assistance, service and maintenance support, as well as preventive maintenance planning.

The Romexis symbol on the dental unit's control panel indicates the state of the connection.

Symbol	Dental unit network settings	Connection between Planmeca Romexis and dental unit
	Romexis connection enabled	On
	Romexis connection enabled	Off
No symbol	Romexis connection disabled	Off

The settings for the Planmeca Romexis connection can only be changed by a qualified Planmeca service technician. If, for example, your dental unit configuration includes the Planmeca Romexis Clinic Management module, but the connection is disabled (no symbol displayed on control panel), contact your Planmeca dealer.

For information on how to use Planmeca Romexis Clinic Management software, see *Planmeca Romexis user's manual*.

9.7 Planmeca ProX X-ray unit

The Planmeca ProX X-ray unit can be mounted to the dental unit pylon.

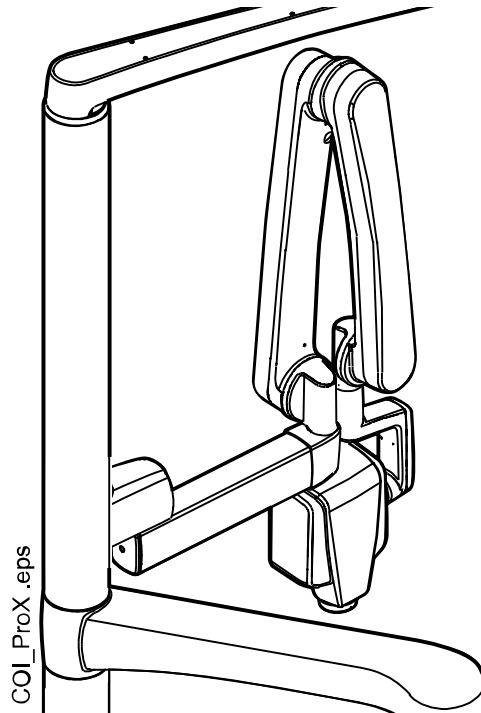

CAUTION

Drive the chair carefully when positioning the ProX X-ray unit.

CAUTION

Do not drive the chair during the exposure.

CAUTION

Do not touch the external PC and the patient at the same time.

CAUTION

Move the ProX X-ray unit behind the pylon when it is not being used.

For more information about Planmeca ProX, see Planmeca ProX User's Manual.

9.8 Planmeca intraoral scanner

The intraoral scanner can be placed in the Flexy holder.

Before using the scanner you must connect it to the dental unit. The connector on the scanner must be carefully attached to the port for the scanner on the cuspidor (1).

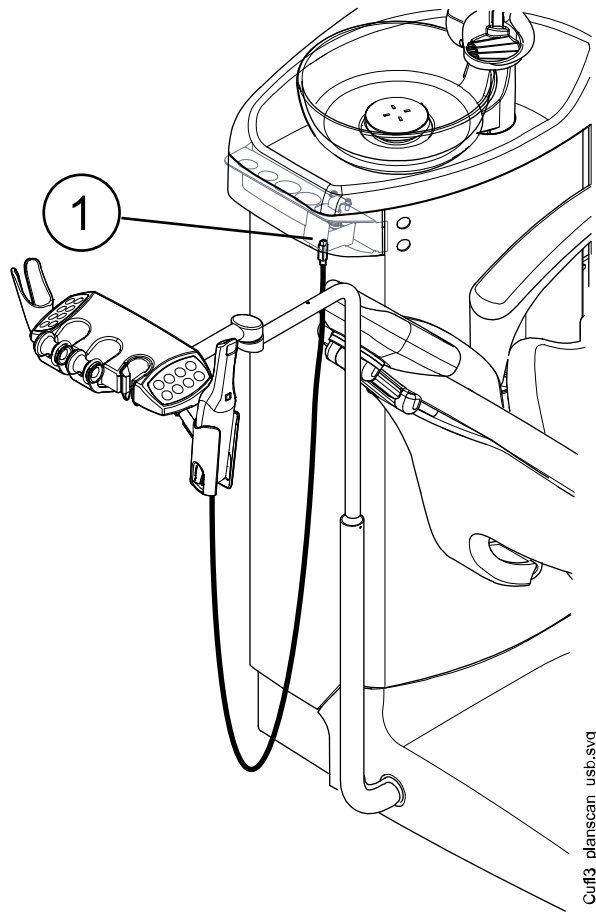

Cuff3_planscan_usb.svg

CAUTION

Make sure that you attach the intraoral scanner connector the right way into the port for the scanner. If the connector is turned the wrong way, it will not go into the port. Use of unnecessary force will break the connector.

NOTE

There are two ports on the cuspidor. One is the port for the intraoral scanner, and the other is a USB port. Make sure you attach the connector to the right port.

NOTE

To avoid splashes on the scanner, remove it from the dental unit after use and place it on the table stand.

For more information about the intraoral scanner, see *Planmeca FIT user's manual*.

10 Planmeca Solanna and Planmeca Solanna Vision operating lights

CAUTION

Do not allow the patient to grab the operating light or its arm when getting seated or getting up from the patient chair.

You can operate the Planmeca Solanna operating light either from the light itself, or from the dental unit's control panel or foot control. It also features a "no touch" function, which means that you can operate the light by waving your hand in front of the sensor.

The Planmeca Solanna Vision operating light has all the features of the Planmeca Solanna operating light and is also equipped with two cameras and a microphone that can be used for video streaming, capturing still images and recording videos.

You can operate the Planmeca Solanna Vision operating light either from the light itself, from the dental unit's control panel or foot control, or from Planmeca Romexis software. All data is stored in Planmeca Romexis.

For information on how to operate the operating light, see section "Planmeca Solanna and Planmeca Solanna Vision operating light" on page 108.

For information on how to operate the camera, see section "Planmeca Solanna Vision camera" on page 116.

For instructions on how to program the operating light, see section "Planmeca Solanna and Planmeca Solanna Vision operating lights" on page 194.

11 Instrument system

11.1 Delivery arms

11.1.1 Over-the-Patient (OP) delivery arm

The OP delivery arm is attached to the top of the dental unit and swings over the chair.

CAUTION

Do not lean on the OP delivery arm.

CAUTION

Do not allow the patient to grab the OP delivery arm when getting seated or up from the patient chair.

The instrument console can be positioned using the handles on the console. The rotation area of the delivery arm is presented in the illustrations below. The items do not need to be locked into position.

The following presents the OP delivery arm with balanced instrument arms.

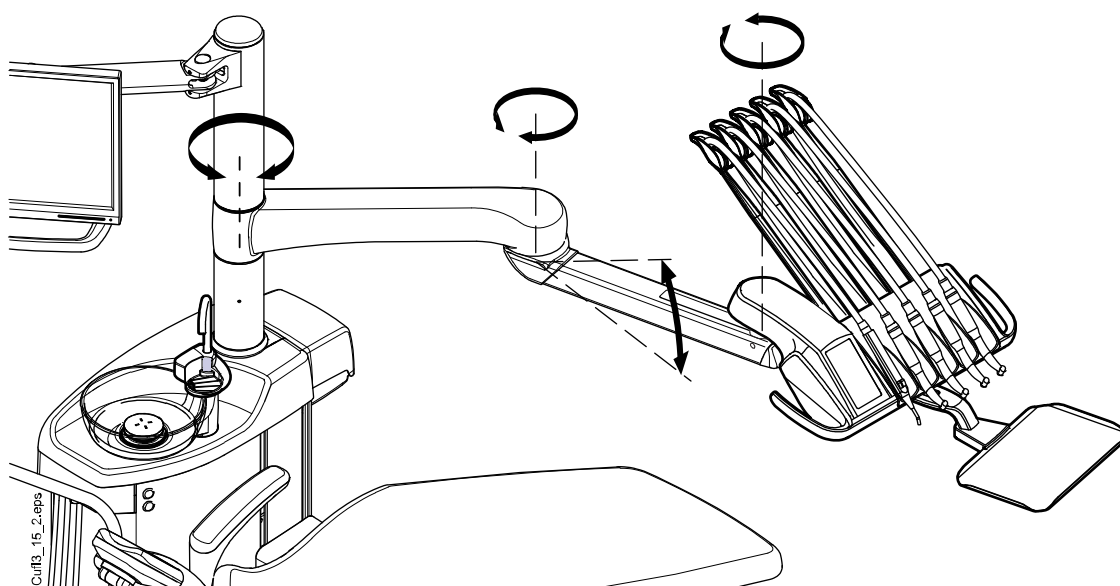

The following presents the OP delivery arm with hanging-tube instruments.

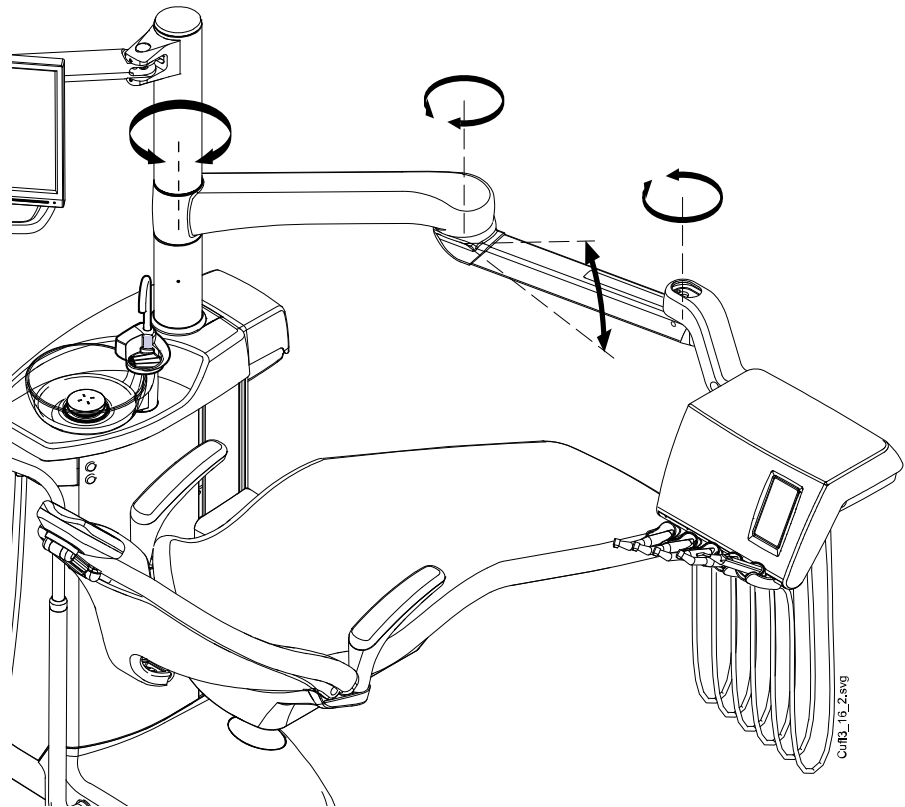

11.1.2 Side delivery arm

The side delivery arm is attached to the cuspidor base and swings under the chair.

CAUTION

Do not stand on the side delivery arm.

The instruments can be positioned using the handle on the instrument console. The arm does not need to be locked into position.

The rotation area of the side delivery arm is presented in the illustration below.

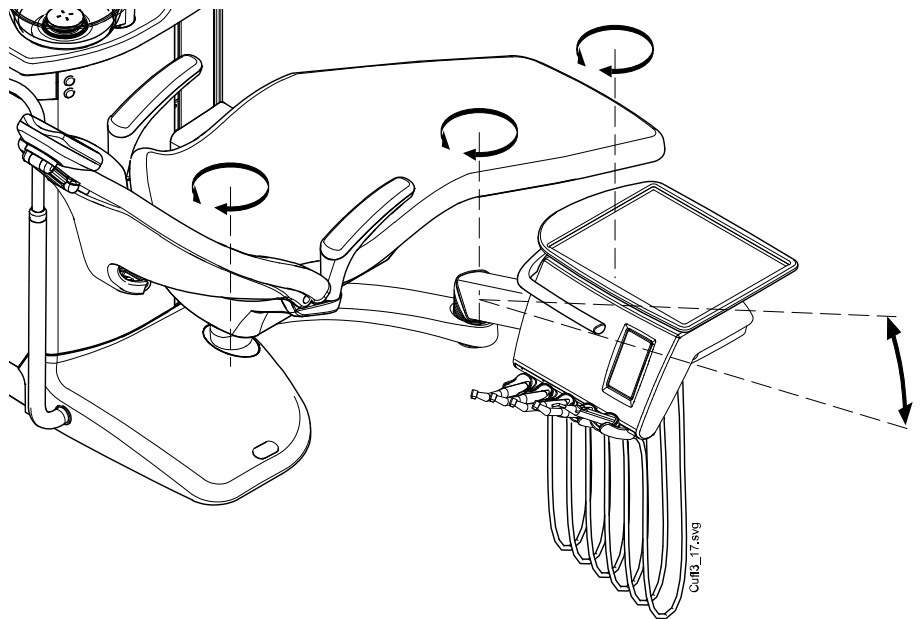

11.2 Instrument console

11.2.1 Instrument console with balanced instrument arms

The console can be equipped with up to five instruments.

The leftmost position is reserved for the syringe only. The other instruments can be positioned in any order in the four remaining positions.

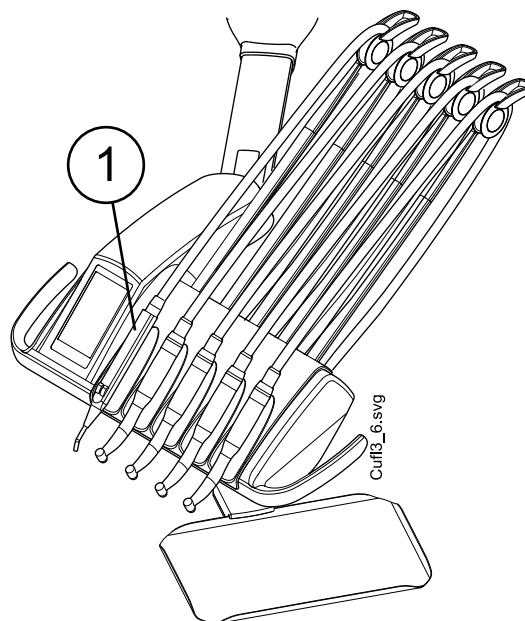

1. Syringe

The instrument arms can be removed by pulling them out from their holders, for example for cleaning or for covering with protective sleeves. The arms are replaced simply by pushing them firmly into their places.

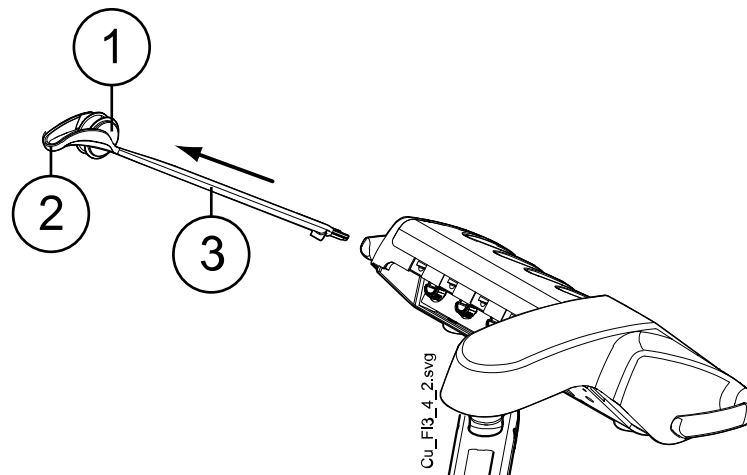

- 1 Roller
- 2 Hose guide
- 3 Instrument arm

When placing the instrument hose back in the roller, bend the hook of the hose guide carefully and pass the hose over the roller.

The balance of the instrument arms can be changed according to the weight of the instrument and personal preferences. Their flexibility can be adjusted as follows:

1. Pull out the roller.
2. Adjust the balance of the instrument arm by moving the roller to a desired position. Note that by positioning the roller higher up, the arm is lighter to bend.
3. Push the roller back in to lock its position

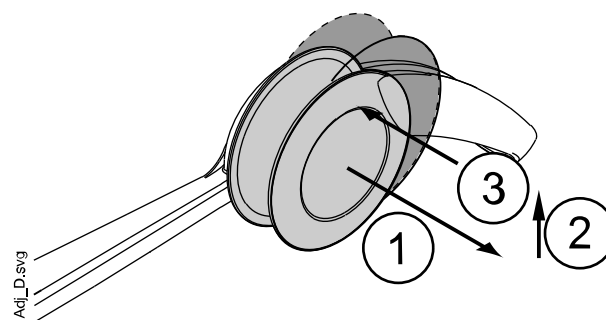

NOTE

When balancing/adjusting the instrument arms, bear in mind that the instruments shall under no circumstances fall over the patient.

11.2.2 Instrument console with hanging-tube instruments

The console can be equipped with up to five instruments. The leftmost position is reserved for the syringe only. The other instruments can be positioned in any order in the four remaining positions.

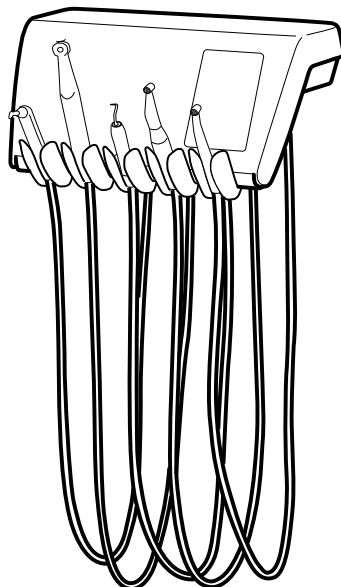

The instrument holders can be removed by pulling them out from their openings, for example for cleaning. The holders are replaced simply by pushing them firmly into their places. The angle of the instrument holder can be slightly adjusted.

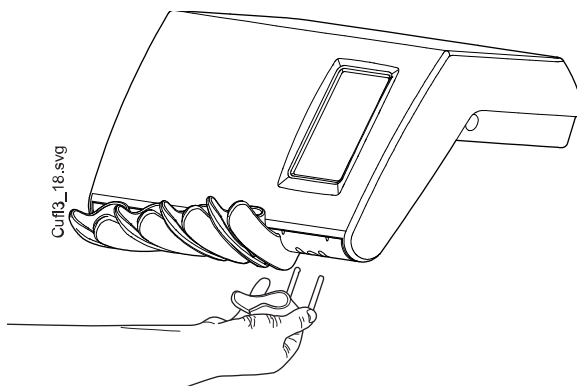

11.3 Quick-connector hoses

The instruments are equipped with quick-connector hoses to be connected to the instrument console. If a syringe and/or a polymerisation light are placed in the Flexy holder, they are connected to the cuspidor.

The hose is connected into place by turning the connector locker clockwise, and removed by turning the connector counter-clockwise. Make sure that the flat side of the connector is upward when connecting the quick-connector hose to the dental unit.

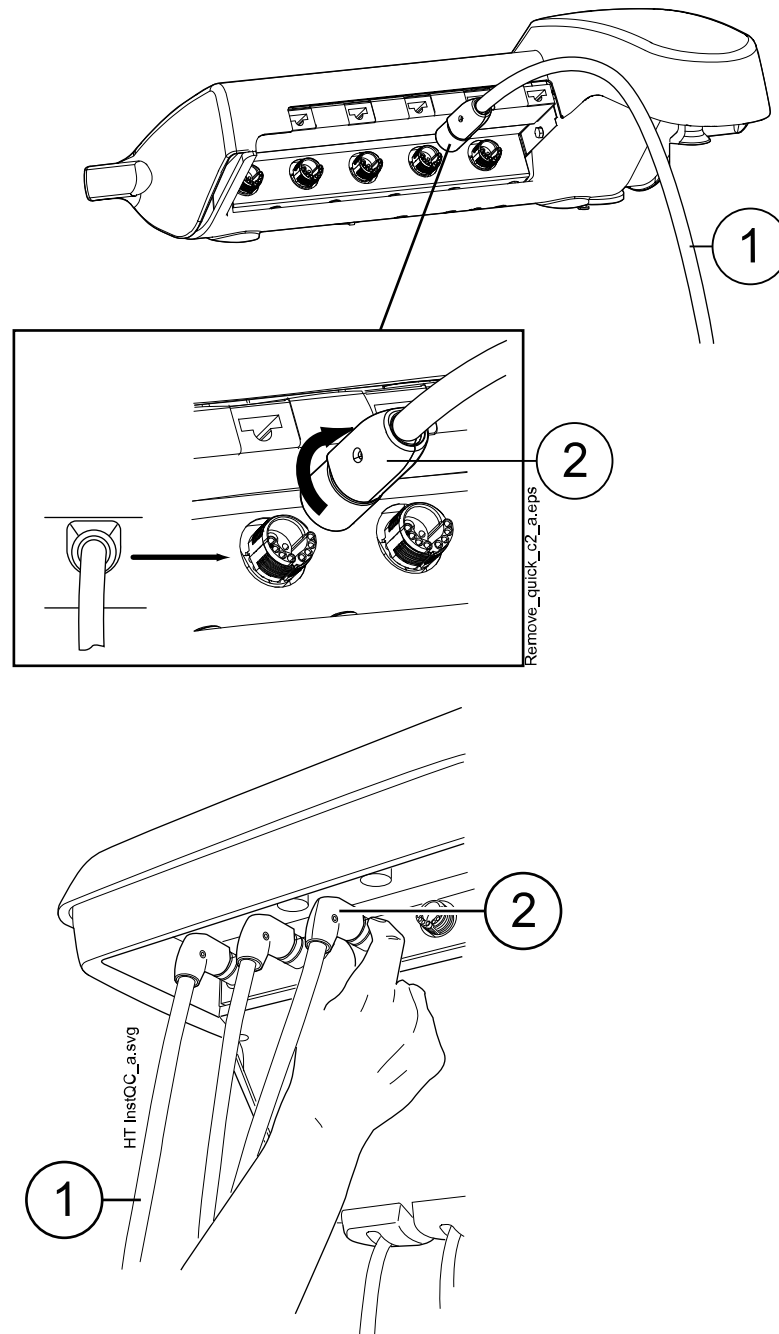

1. Instrument hose
2. Quick-connector

Switch the unit off before opening the quick-connectors. When disconnecting the syringe, empty the water and air from the hose before opening the connector.

The instrument location on the instrument console can be changed simply by removing the instrument with its hose and reconnecting it to the new place. The old instrument settings will remain the same despite of the new location of the instrument hose.

The instrument selection on the instrument console can also be interchanged. The settings of the eight last used instruments are stored in the memory, and are recalled when the instrument is reconnected.

NOTE

Make sure that the hoses are properly connected to avoid any leakage.

NOTE

Always make sure that the instrument hose is correct for the used instrument. The control system identifies the instrument hose, not the instrument. The control system does not recognise if an instrument has been changed on the instrument hose.

NOTE

If the outer casing of the instrument hose is broken, the entire hose must be replaced, although the hose itself might still be functioning.

NOTE

The instrument sealings must be correct and unbroken, and the instrument must be attached properly to the hose connector. The leakage between the instrument and the connector causes leakage air to drift into the hose lining.

NOTE

A scaler requires additional electronics and the scaler type can not be changed without changing electronics.

11.4 Instrument functions

The instrument console has five instrument positions. You can set each instrument so that the following functions will, where applicable, either be on or off when the instrument is active (i.e. picked up from the instrument console):

- instrument spray
- automatic chip blow
- instrument light
- reverse rotation (micromotors)
- quickstart (air driven instruments)
- instrument speed/power reduction
- torque limit (Bien-Air MCX and KaVo KL703 LED micromotors)
- torque limit and drive mode (Bien-Air MX2 Plus, KaVo KL703 LED with endo, and Morita TORX micromotors).

The type or magnitude of the following functions can be programmed:

- instrument spray
- automatic chip blow
- instrument light
- instrument speed/power reduction
- torque limit
- drive mode for Bien-Air MX2 Plus and KaVo KL703 LED with endo micromotors
- apical action for Morita TORX micromotors.

11.4.1 Instrument spray

The instrument spray can be programmed to be on or off when the instrument is active (i.e. picked up from the instrument console). Also, the type of spray can be programmed.

If the Planmeca Sterile water system is in use, the sterile water mode can be enabled/disabled.

For more information, see sections "Instrument spray" on page 178 and "Enabling/disabling sterile water mode" on page 179.

11.4.2 Automatic chip blow

The automatic chip blow can be programmed to be on or off when the instrument is active (i.e. picked up from the instrument console). Also, the type of automatic chip blow can be programmed.

For more information, see section "Automatic chip blow" on page 180.

11.4.3 Instrument light

The instrument light can be programmed so that it will either be on or off when an instrument is active (i.e. picked up from the instrument console). Also, the intensity can be adjusted. For more information, see section "Instrument light" on page 180.

The instrument light can be on only in one instrument at a time, for example, the instrument light of the syringe will switch off, if the light of the active instrument is switched on.

11.4.4 Reverse rotation of micromotor

The direction of the micromotor rotation can be reversed, see section "Reverse rotation" on page 127.

11.4.5 Quickstart of air driven instruments

The turbine can be set to start with maximum speed, see section "Quickstart" on page 155.

11.4.6 Instrument speed/power limit

The instrument speed/power limit can be set to be on or off when the instrument is active (i.e. picked up from the instrument console), see sections "Speed/power limit" on page 127 (micromotor), "RPM" on page 132 (Bien-Air MCX and KaVo KL703 LED micromotors), "RPM" on page 134 (Bien-Air MX2 Plus and KaVo KL703 LED with endo micromotors), "RPM" on page 142 (Morita TORX micromotor) and "Speed/power limit" on page 157 (turbine).

For the Bien-Air MX-i micromotor the torque limit is always on and can not be switched off.

The power reduction level can be programmed, see sections "Instrument speed/power limit" on page 178 (micromotor and turbine), "Bien-Air MCX and KaVo KL703 LED micromotors" on page 181, "Modifying preset values" on page 183 (Bien-Air MX2 Plus and KaVo KL703 LED with endo micromotors), "Modifying preset values" on page 186 (Bien-Air MX-i micromotor) and "Modifying preset values" on page 188 (Morita TORX micromotor).

NOTE

The instrument speed/power limit does not affect the air driven instruments for which quickstart has been selected.

11.4.7 Torque limit

The torque limit for the Bien-Air MCX, Bien-Air MX2 Plus, KaVo KL703 LED, KaVo KL703 LED with endo, and Morita TORX micromotors can be set to be on or off when the instrument is active (i.e. picked up from the instrument console), see sections "Torque" on page 131 (Bien-Air MCX and KaVo KL703 LED), "Torque" on page 133 (Bien-Air MX2 Plus and KaVo KL703 LED with endo) and "Torque" on page 140 (Morita TORX).

For the Bien-Air MX-i micromotor the torque limit is always on and can not be switched off.

The torque limit value can be programmed, see sections "Bien-Air MCX and KaVo KL703 LED micromotors" on page 181, "Modifying preset values" on page 183 (Bien-Air MX2 Plus and KaVo KL703 LED with endo micromotors), "Modifying preset values" on page 186 (Bien-Air MX-i micromotor, only presets i4 - i5) and "Modifying preset values" on page 188 (Morita TORX micromotor).

For the Bien-Air MX2 Plus and KaVo KL703 LED with endo micromotors you can program the drive mode, that is, the instrument function when the torque limit is reached, see section "Modifying preset values" on page 183. The drive mode for the Bien-Air MCX, KaVo KL703 LED and Morita TORX micromotors can not be programmed.

11.4.8 Apical action

For the Morita TORX micromotor you can program the apical action, that is, what happens when the file tip reaches a certain point in the root canal. For instructions, see section "Apical action" on page 142.

11.5 Trays**11.5.1 Quick-connect tray**

The quick-connect tray is available for the instrument console with balanced instrument arms.

The tray is attached to the mounting arm with a magnetic connector and can easily be attached and detached. You can rotate the tray 360° to the desired position. The maximum load on the quick-connect tray is 2 kilograms (4.4 lbs).

The tray mounting arm is attached to the instrument console with a quick-connector. To remove the tray assembly from the instrument console, pull the ring of the locking mechanism outwards (1) and then pull the tray arm away from its position (2).

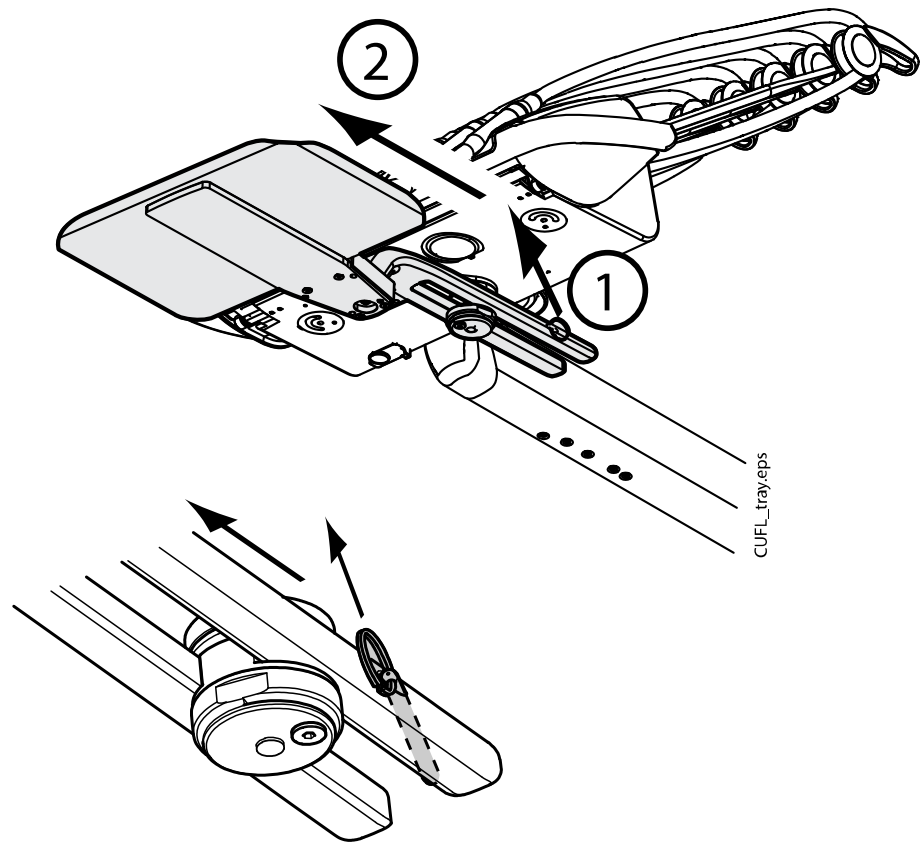

The mounting arm can be attached to the instrument console by pushing it to its position.

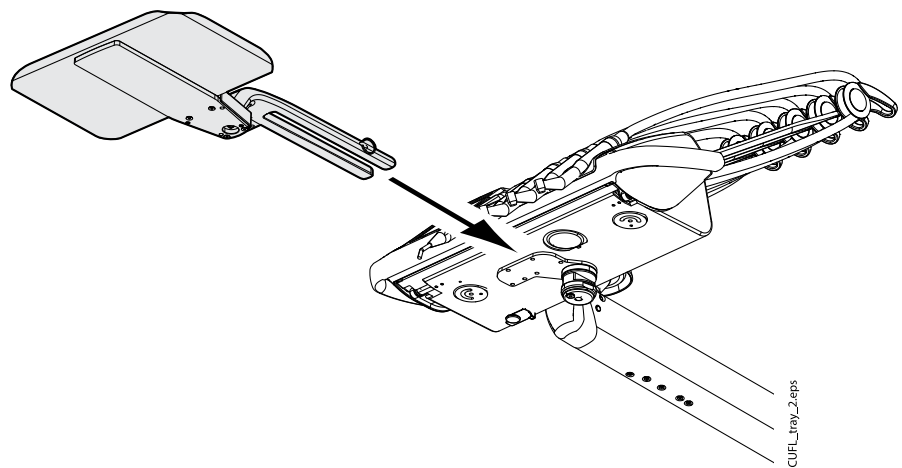

11.5.2 Integrated tray

The integrated tray is available for OP-deliveries with hanging-tube instruments. The maximum load on the tray is 2 kilograms (4.4 lbs).

The integrated tray is located on the left side of the instrument console.

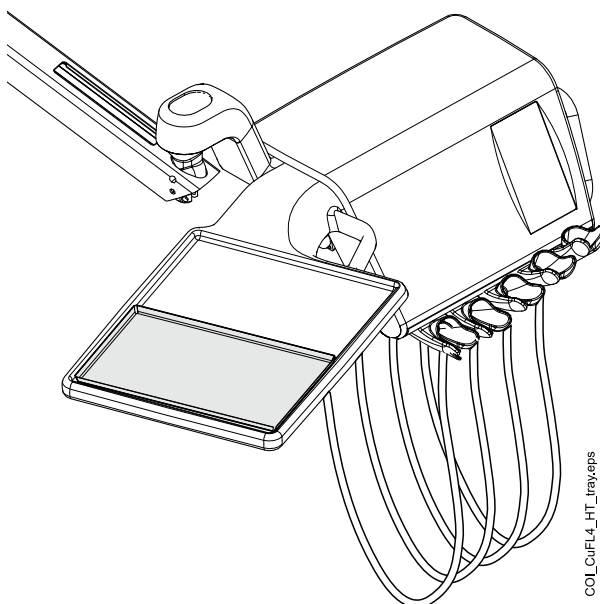

11.5.3 Top tray

The top tray is placed on top of the instrument console and is available for OP-deliveries with hanging-tube instruments and for the mobile cart. The maximum load on the top tray is 2 kilograms (4.4 lbs).

The tray is attached to the instrument console with a quick-connector, enabling an easy attachment and detachment of the tray.

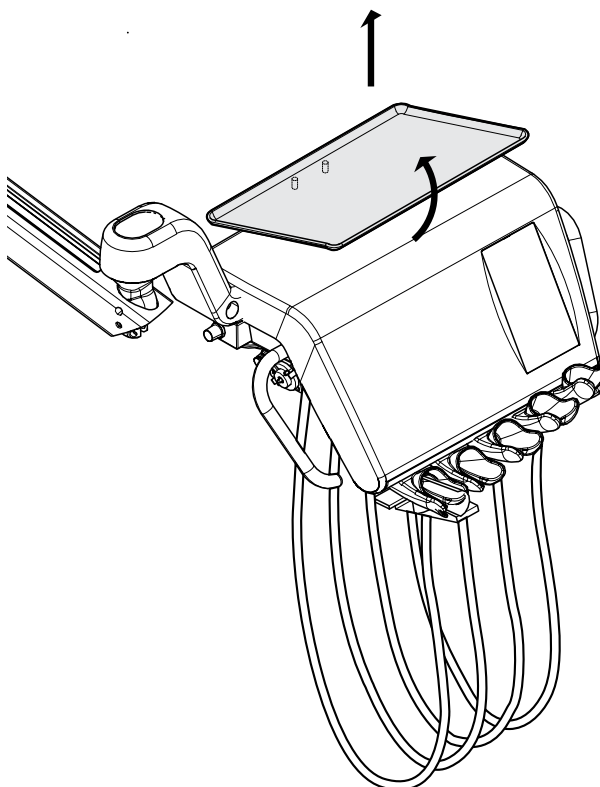

11.5.4 Rotating tray

The rotating tray is placed on top of the instrument console and is available for side deliveries. The maximum load on the tray is 2 kilograms (4.4 lbs).

You can rotate the tray 180° to the desired position.

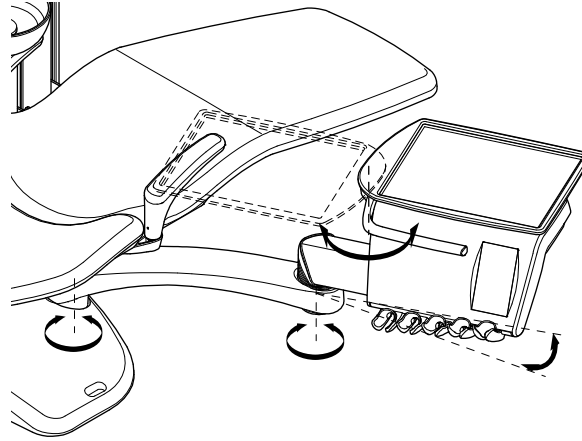

11.5.5 Double tray

The double tray is available for side deliveries. It is a combination of the top tray and the rotating tray. The maximum combined load on the trays is 2 kilograms (4.4 lbs).

The top tray is attached to the instrument console with a quick-connector, enabling an easy attachment and detachment of the tray (see picture in section "Top tray" on page 41.)

The rotating tray can be rotated 180° to the desired position.

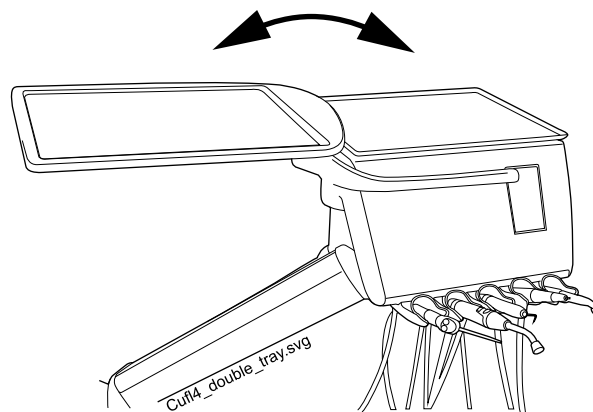

11.5.6 Column tray

The column tray is available for all dental units with a column. In OP deliveries the mounting arm is attached to the column above the OP delivery arm.

The tray is attached to the mounting arm with a magnetic connector and can easily be attached and detached. You can rotate the table 180° to the desired position. The maximum load on the quick-connect tray is 2 kilograms (4.4 lbs).

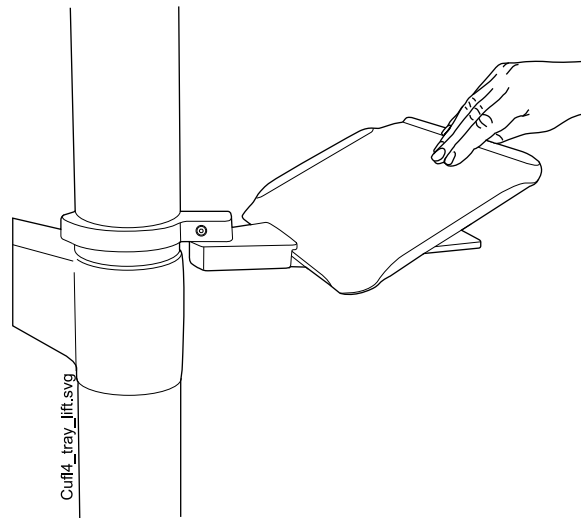

11.5.7 Cuspidor tray

CAUTION

Do not allow the patient to grab the tray when getting seated or getting up from the patient chair.

NOTE

Always place the tray in home position when it is not used.

NOTE

Make sure that the tray is not above the patient chair when you drive the chair upward.

A cuspidor tray can be installed to dental units without a bowl.

The tray assembly is attached to the top of the cuspidor. The tray is held in place with a magnetic connector and can easily be attached and detached. The maximum load on the tray is 2 kilograms (4.4 lbs) and it can be rotated as shown in the picture below.

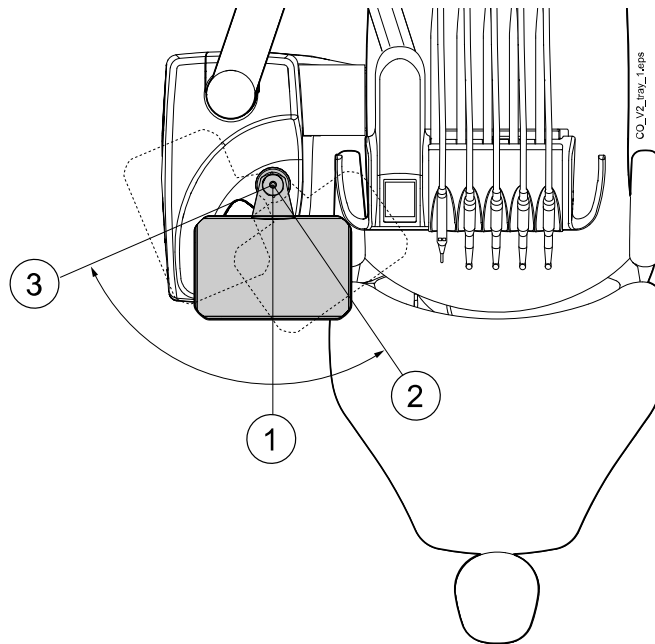

- 1 Installation position
- 2 Tray positioned above patient
- 3 Home position

If the tray assembly (1) for some reason comes off the cuspidor, you can put it back by placing it into the opening in the cuspidor top cover, at the same time making sure that the peg goes into the slot (2) in the opening. When the tray assembly is in place, place the tray (3) on the assembly.

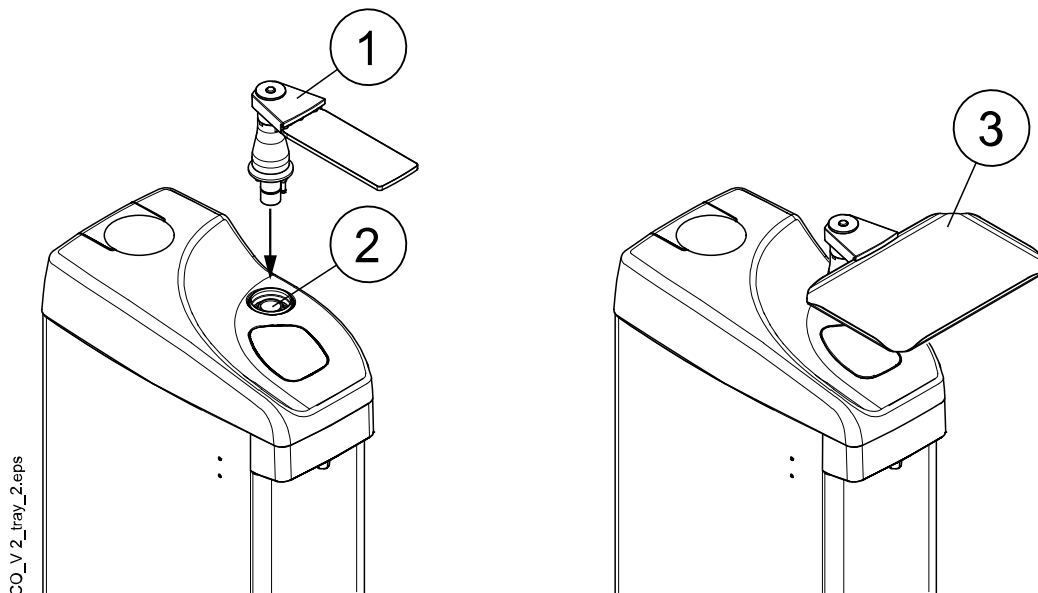

11.6 Sterile water system

11.6.1 Introduction

When the sterile water system is used, sterilised water is fed from a disposable sterile water bag through an external disposable tube to a surgical handpiece or scaler. The instrument must have an externally mounted spray nozzle on which the sterile water tube is fitted.

CAUTION

Before using an instrument with sterile water, make sure water comes out from the instrument.

CAUTION

The sterile water system can only be used with surgical handpieces that are intended for sterile use, as well as with scalers with external sterile water connection. If other instruments are used, the system is not sterile.

CAUTION

To ensure sterile conditions, extra precaution should be taken to make sure that correct procedures are followed and all the components and tools used (e.g. scissors) are sterile.

CAUTION

The sterile water bag, nozzle and tubes are disposable and intended for single use only.

CAUTION

Inspect sterile packaging for damage. If sterile packaging is damaged, the item must not be used.

CAUTION

The attachment of the sterile water bag, nozzle and tubes to the dental unit is to be performed by dental personnel only.

CAUTION

Be careful not to squeeze your fingers in the water pump.

NOTE

When using sterile water, be careful not to step on the sterile water tubes or otherwise squeeze them.

Refer also to the documentation delivered with the sterile water bag and the sterile water tube.

A sterile water system can be installed to the following dental unit configurations:

- Over-the-patient delivery with balanced instrument arms (1)
- Over-the-patient delivery with hanging-tube instruments
- Side delivery with hanging-tube instruments (2)

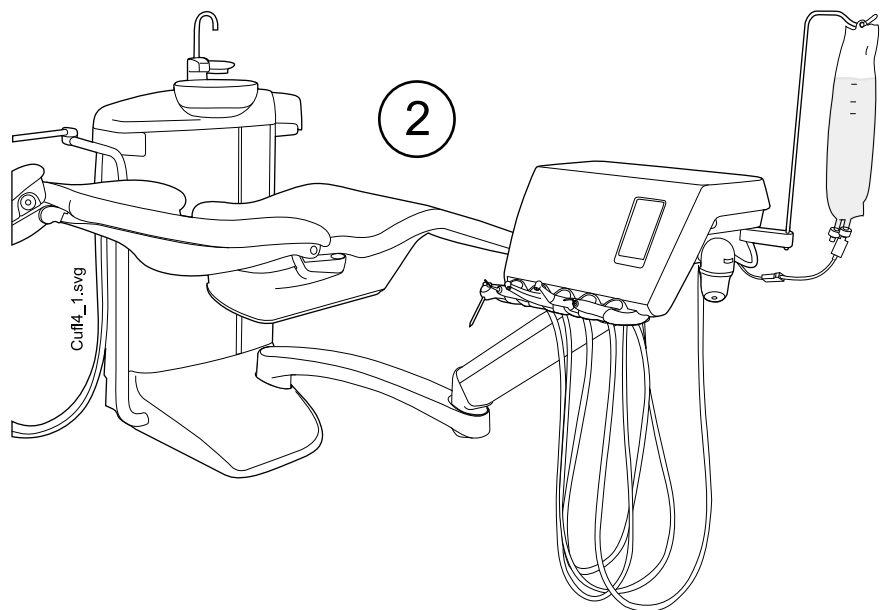
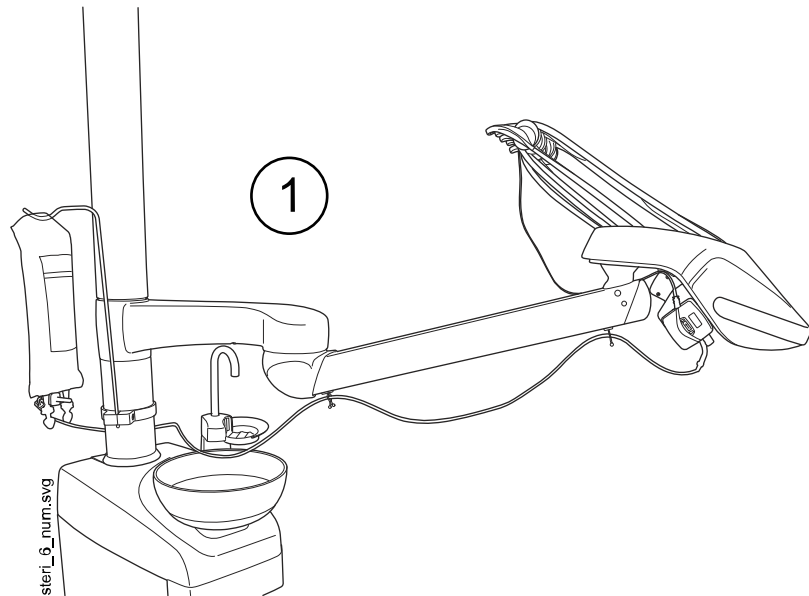

11.6.2 Setting up sterile water system

Before using sterile water, you need to set up the sterile water system as described below and edit the instrument spray settings so that sterile water is used (see section "Enabling/disabling sterile water mode" on page 179).

1. Hang the sterile water bag on the holder.

In OP-deliveries, the holder is attached on the pylon, and in side deliveries it is attached to the instrument console.

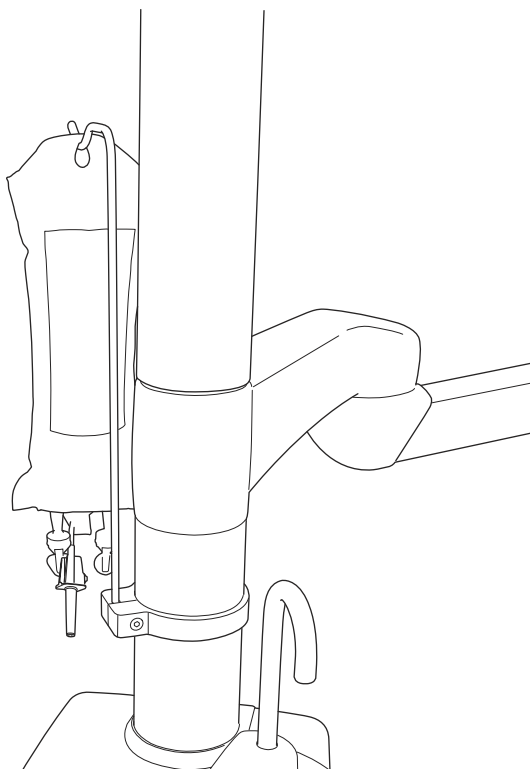

2. Open the lid of the water pump and place the silicone part of the sterile water tube in the pump.

Make sure that the sterile water tube is inserted so that water is pumped from the sterile water bag to the instrument. The arrow on the pump indicates the direction of the water flow, away from the bag and toward the instrument.

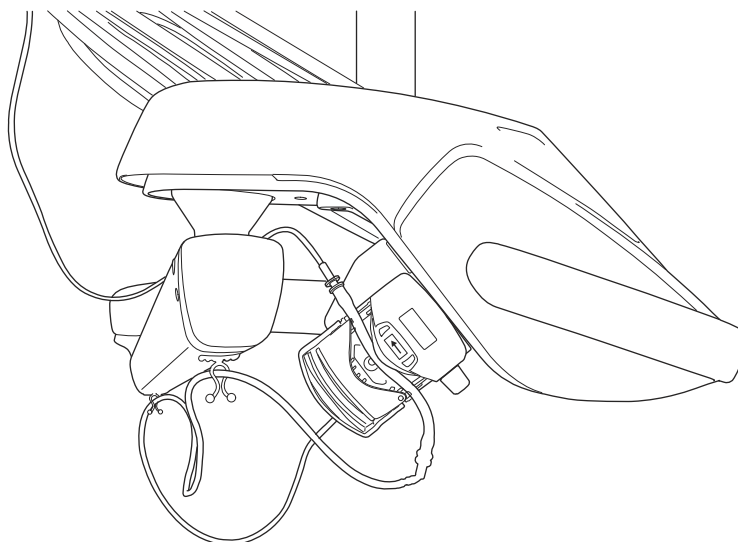

3. Close the lid of the pump.
4. Connect the sterile water tube to the sterile water bag by pushing the nozzle firmly into the opening at the bottom of the sterile water bag.
5. Route the other end of the tube to the instrument hose.

6. Connect the water tube to the instrument by sliding the tube over the externally mounted spray nozzle as shown in the figure below.

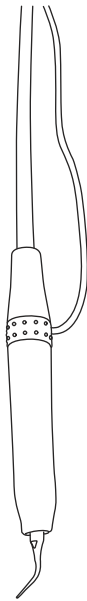

7. Attach the long end of the sterile water tube to the OP delivery arm with the clips included in the sterile water tube package.

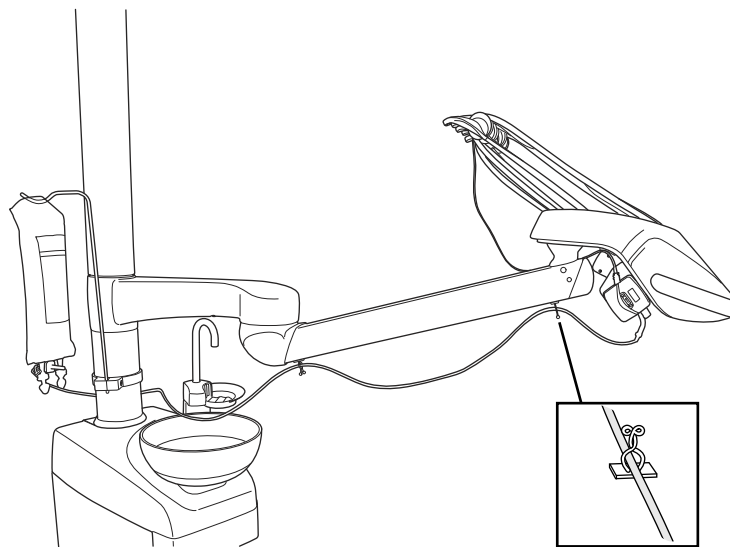

8. Enable sterile water from the instrument spray settings. See section "Enabling/disabling sterile water mode" on page 179.

11.6.3 Extending sterile water tube

If the sterile water tube is too short, you can extend it with one or two extension tubes, depending on how long a sterile water tube you need.

The following instructs how to join two extension tubes with the sterile water tube before routing the tube from the instrument to the sterile water bag, but note that you may well use only one extension tube, provided it gives you the required length. You may also cut the extension tube shorter, if needed.

1. Cut the sterile water tube at location marked with (1) in picture.

2. Attach the two extension tubes to each other with a tube joint (provided with extension tube pack) (2). This creates the joint extension tube.
3. Attach one end of the joint extension tube to the sterile water tube with nozzle (3).
4. Attach the other end of the joint extension tube to the sterile water tube with pump part (4).
5. This part (5) goes into the sterile water bag.
6. This part (6) goes into the pump.

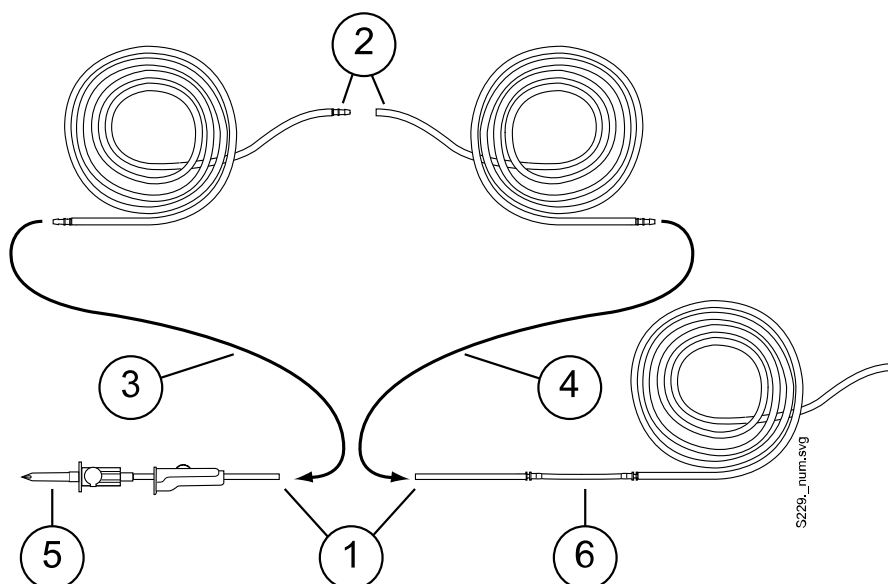

11.6.4 Adjusting sterile water flow rate

Turn the black knob on the instrument console to adjust the sterile water flow rate.

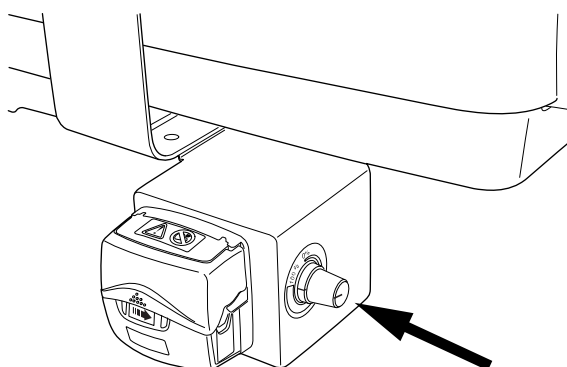

11.6.5 Adjusting sterile water volume

Use the clamp on the sterile water tube to adjust the water volume. Push the slide forward to reduce the volume, and backward to increase the volume.

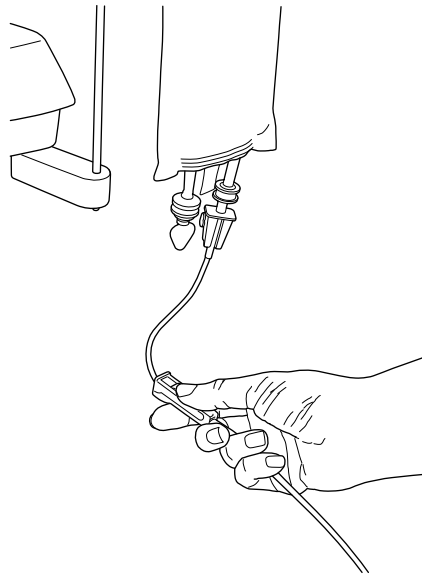

11.6.6 Removing sterile water bag holder (OP deliveries)

The sterile water bag holder that is mounted on the column can be removed from its mount as follows:

1. Loosen the screw on the mount with a 4 mm Allen key.
2. Remove the sterile water bag holder.
3. Tighten the screw.

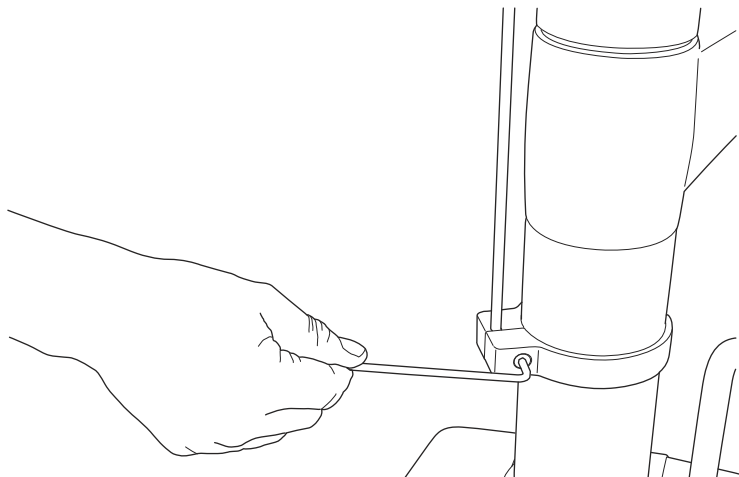

12 Suction system

12.1 Suction arms

12.1.1 Adjustable suction arm

The adjustable suction arm is attached to the side of the unit base.

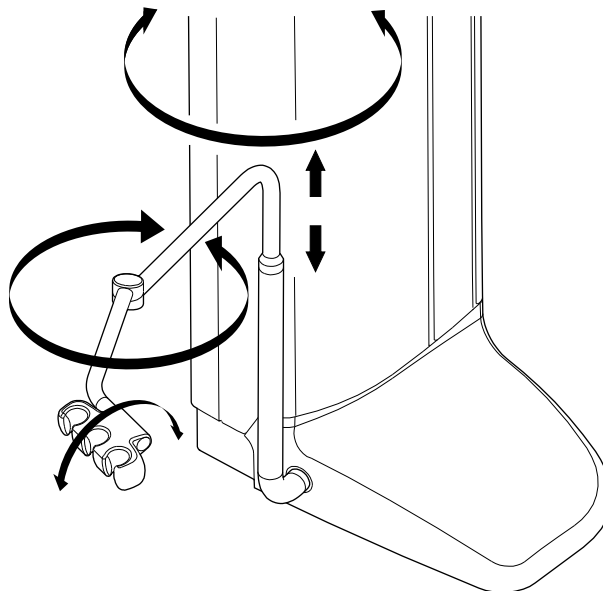

12.1.2 Adjustable suction arm with Flexy holder

The adjustable suction arm with a Flexy holder is attached to the side of the unit base.

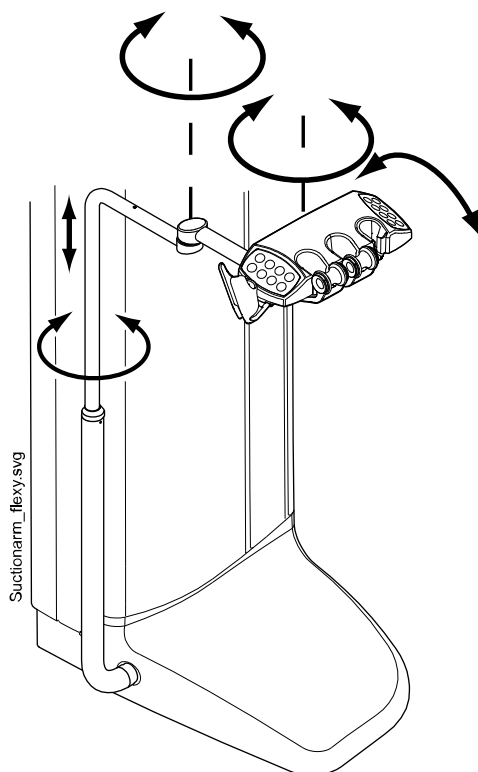

12.1.3 Left/right suction arm with Flexy holder

The left-right suction arm with a Flexy holder is attached to the side of the unit base.

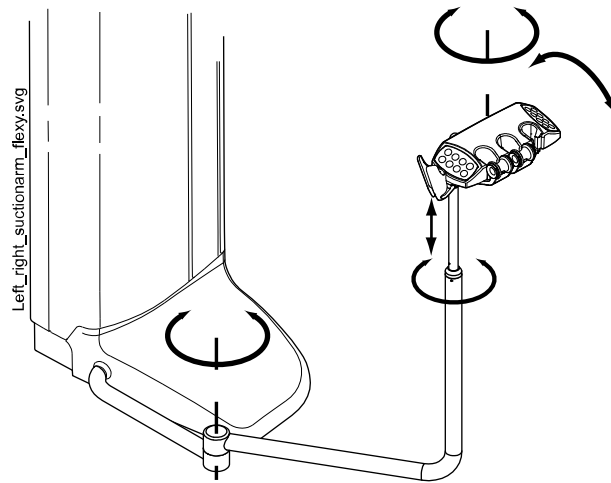

12.1.4 Chair-mounted adjustable suction arm with Flexy holder

The chair-mounted adjustable suction arm with a Flexy holder is mounted to the underside of the patient chair.

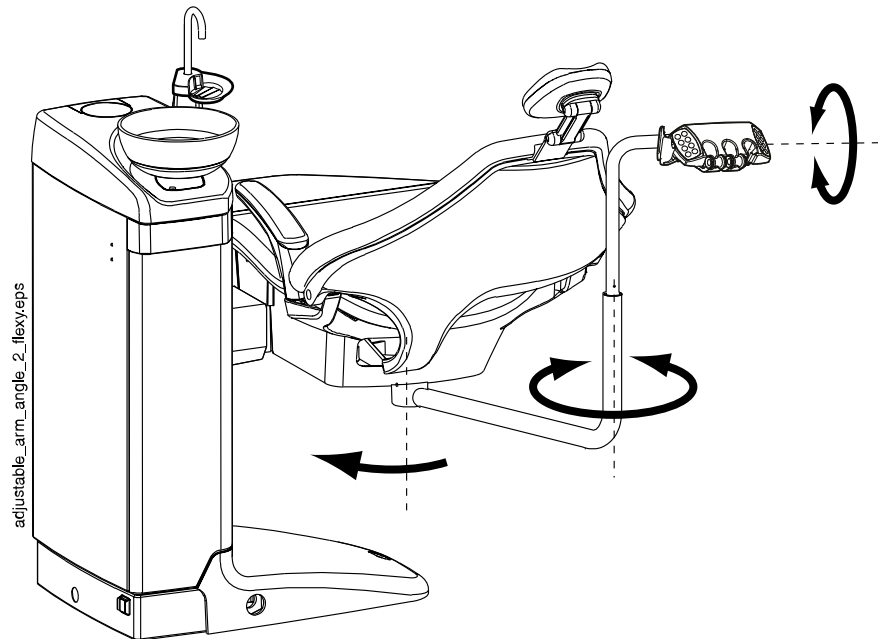

12.1.5 Chair-mounted left/right suction arm with Flexy holder

The chair-mounted left/right suction arm with a Flexy holder is mounted to the underside of the patient chair.

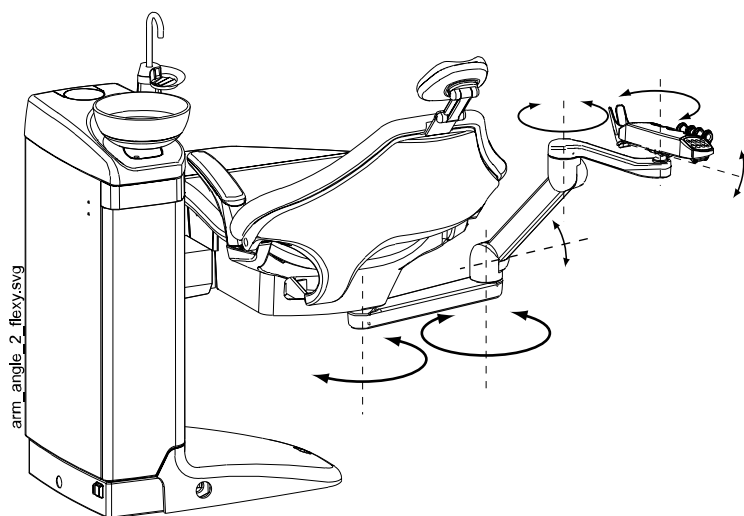

NOTE

If the chair is equipped with a chair-mounted left/right suction arm, make sure that the Flexy holder does not hit the cuspidor when driving the chair up.



NOTE

If the chair is equipped with a chair-mounted left/right suction arm, make sure that the Flexy holder is not above the cuspidor when driving the chair down. If the chair does not move downward and H 03 is displayed, check that the chair-mounted arm is not in the upmost position. This arm position prevents the chair from moving downward.



12.2 Flexy holder

The suction handpieces are placed in the Flexy holder.

The Flexy holder is a suction holder that is attached to the suction arm. Its integrated control panels enable you to control selected functions of the dental unit. For more information on the control panel, see section "Control panel on Flexy holder" on page 71.

The Flexy holder has three openings. The two left-most openings can be equipped with suction handpieces and the right-most with the assistant's syringe. In addition, one or two supplementary holders or a holder for the intraoral scanner can be placed on either side of the Flexy holder. The supplementary holder can be equipped with a USB intraoral camera or a polymerisation light.

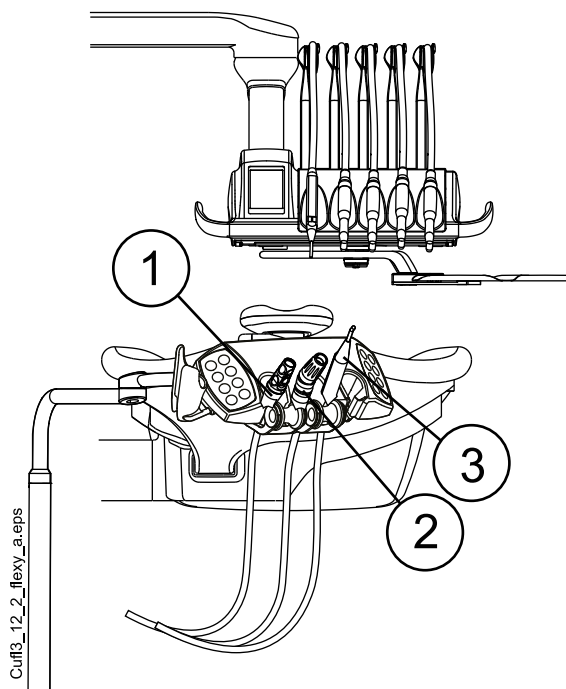

1. Saliva suction handpiece
2. High-volume suction handpiece
3. Syringe

NOTE

The intraoral scanner and the USB intraoral camera can not be simultaneously attached to the Flexy holder. If the intraoral scanner is placed in the Flexy holder, the USB intraoral camera can be placed in the instrument console.

Removing holders

The instrument and supplementary holders can be removed from the Flexy holder, for example for cleaning.

Remove the instrument holder by squeezing it from the bottom and at the same time lifting it upward. To replace it, squeeze the holder and insert it into its place.

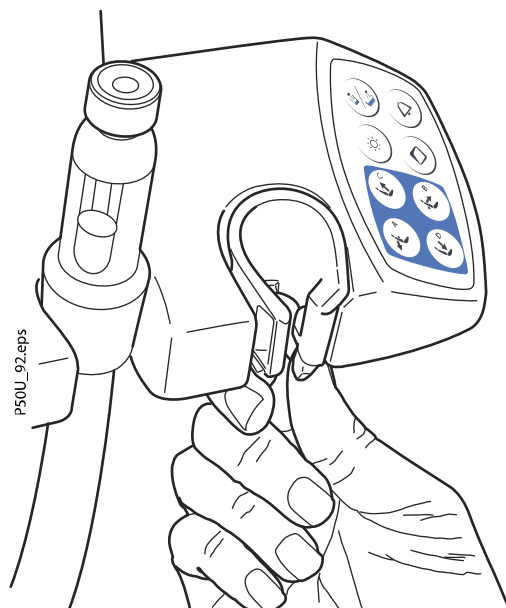

Remove the supplementary holder by pulling it out from the Flexy holder. To replace it, push it firmly into its place.

Remove the holder for the intraoral scanner by pressing the trigger (see arrow in picture) and pulling the holder out from the Flexy holder. To replace the holder for the intraoral scanner, push it firmly into its place.

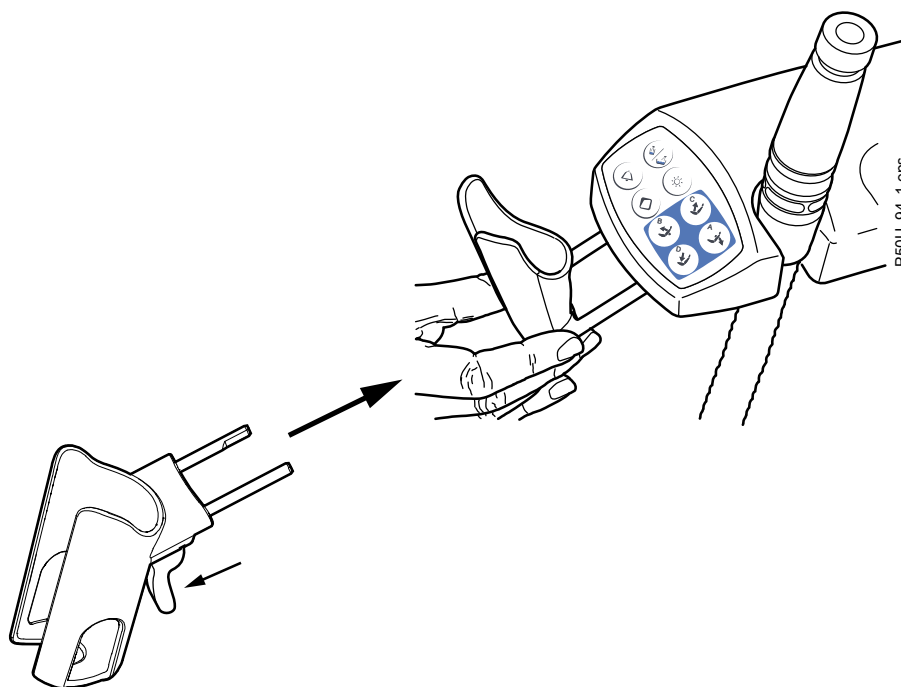

12.3 Removing and replacing suction tubes

Steps

1. To minimise contamination risk, perform suction cleaning.
For instructions, see section "Suction cleaning" on page 214.

2. Remove the side cover plate by pulling it out from the cuspidor.
3. Detach the securing ring (1) from the suction tube.

NOTE

You can grease the securing ring with non-toxic vaseline to make it easier to remove.

4. Remove the suction tube (2) from the suction tube connector.

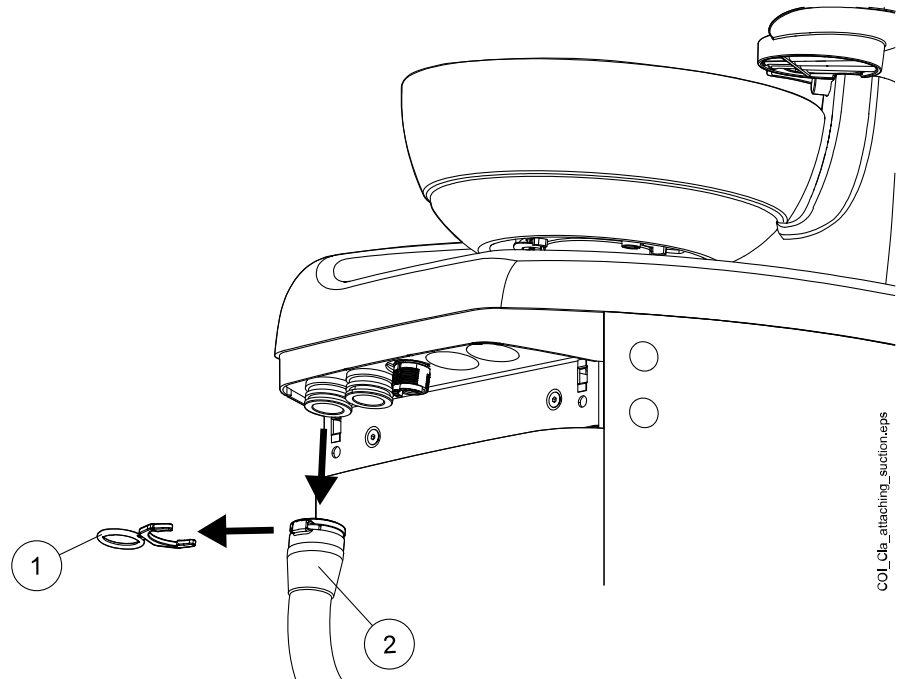

5. Replace the suction tubes in the reverse order.

13 Patient chair

CAUTION

Make sure no one sits on the legrest or the backrest.

CAUTION

The detachable foot cover is not intended to be in contact with bare skin.

NOTE

The patient chair can be equipped with a fixed or an automatic legrest.

NOTE

If, for example, the patient feels sick and starts to vomit while lying in the chair, you can raise the backrest quickly by pushing it up by hand from behind the backrest. Note, however, that the backrest does not stay up by itself but must be supported the whole time and lowered in a controlled manner.

NOTE

Dark coloured clothes may cause coloured stains on the bright coloured upholstery.

13.1 Patient recognition

A sensor in the patient chair recognises if there is a patient in the chair and forwards information about this to Planmeca Romexis Clinic Management software.



When a patient is in the chair, a **Patient** icon is displayed on the control panel.



When the chair is empty, an **Empty chair** icon is displayed on the control panel.

13.2 Automatic legrest

The automatic legrest can be moved synchronously to the movements of the backrest, that is, when you drive the backrest down, the automatic legrest is driven up. Use the chair movement buttons to drive the patient chair. Notice that the lever underneath the legrest has to be unlocked (moved to the right) in order to move the legrest with the backrest. Support the legrest with your other hand when locking or unlocking the lever.

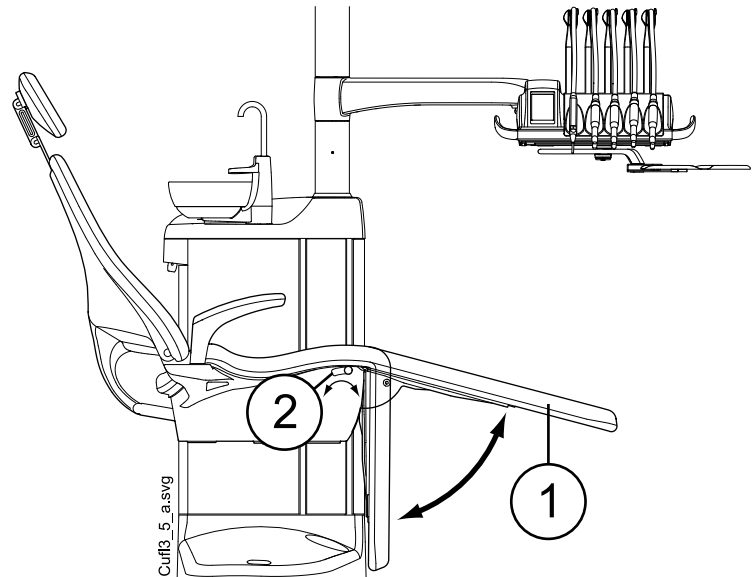

1. Automatic legrest
2. Lever

The automatic legrest can be locked approximately 18° from the horizontal position. To lock the legrest, the lever has to be moved to the left. Support the legrest with your other hand when locking or unlocking the lever. Notice that the backrest will move upward and downward when the legrest is locked.

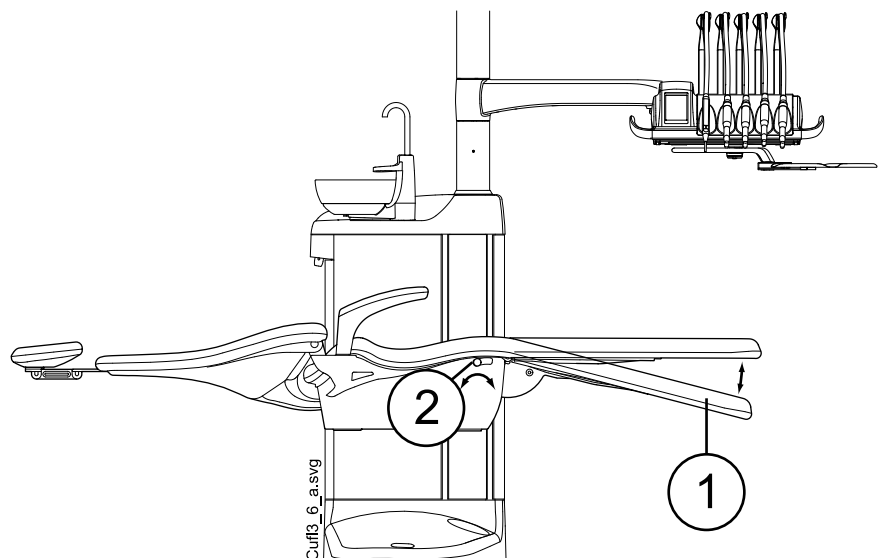

1. Approx. 18° from the horizontal position
2. Lever

13.3 Trendelenburg position

If required, the patient chair can be inclined from the horizontal position to the Trendelenburg position. In the Trendelenburg position the legrest is in the horizontal position and the backrest is driven -4° from the horizontal position.

To drive the patient chair to the Trendelenburg position, first drive the chair to horizontal position, lock the legrest manually by moving the lever underneath the legrest to the left, and press the **Backrest down** button until the backrest reaches a position of -4° .

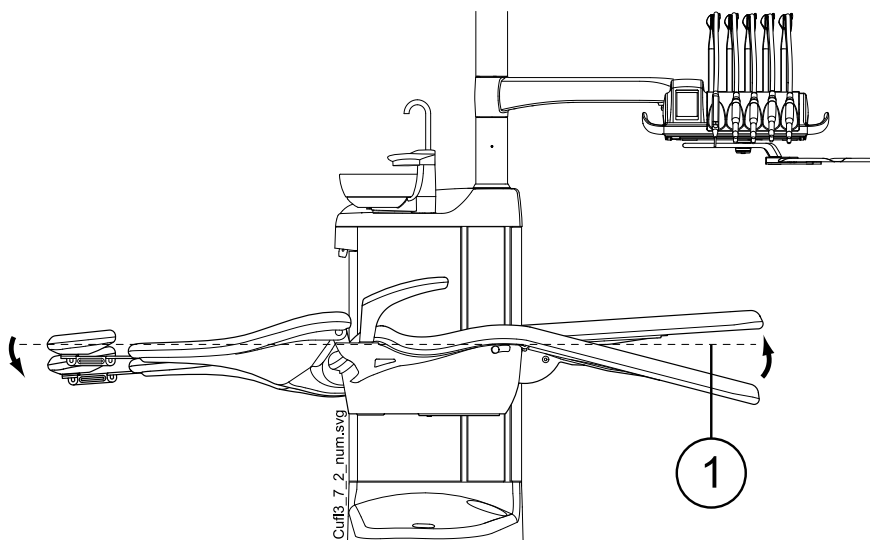

1. Horizontal position

13.4 Armrests

The right armrest can be moved 90° outwards. Before you move the armrest horizontally you must lift it slightly to unlock it. The armrest can be locked into the positions 1 and 3 presented below. The armrest can be removed when it is in position 2.

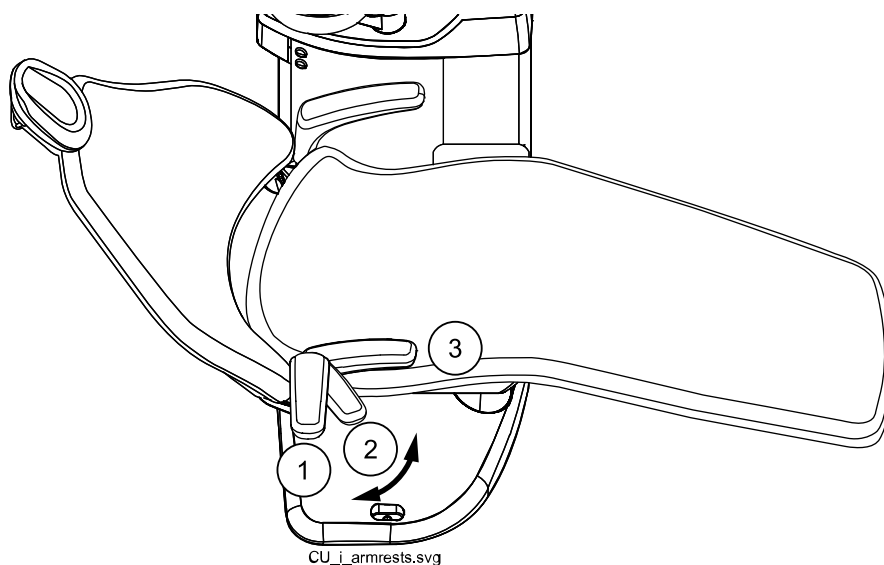

Surgical armrest

As an option, a surgical armrest is available. The patient's arm can be strapped to the armrest when, for example, infusing saline solution.

NOTE

Make sure that the patient does not lean on the armrest when getting in or out of the chair.

To move the armrest horizontally you must lift it slightly to unlock it.

To replace the right standard armrest with the surgical armrest you must first detach the standard armrest. To do so, lift the armrest slightly to unlock it and move the armrest to a 45° position. When the armrest is in a 45° angle, lift it straight up to remove it (1).

Once you have removed the standard armrest, place the surgical armrest on the spindle in a 45° angle, push the armrest down and rotate in either direction until it locks into place (2).

The surgical armrest is removed in the same way as the standard armrest.

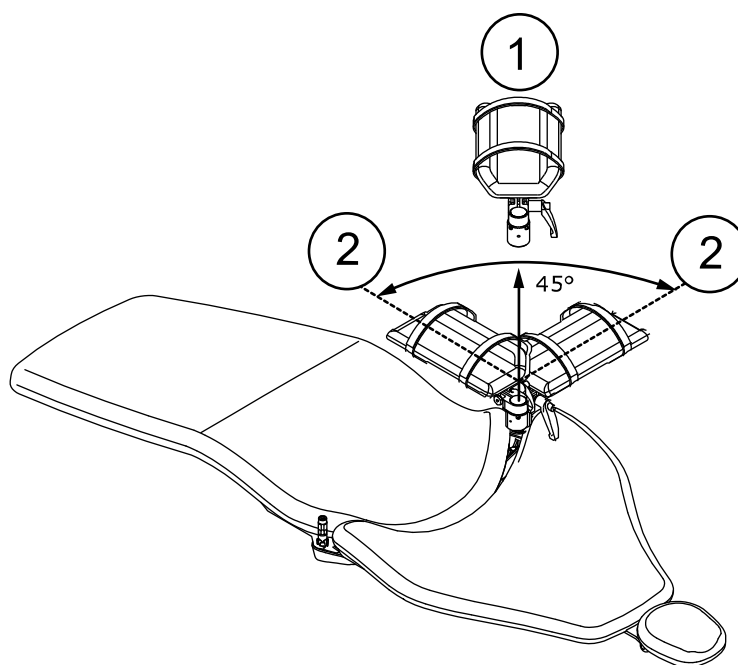

13.5 Headrest

There are two headrest options: the standard headrest and the swift headrest.

Both headrests can be equipped with either an oval or a surgical cushion.

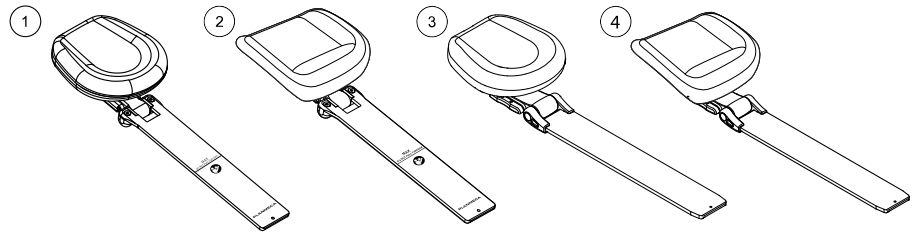

- 1 Standard headrest with oval cushion
- 2 Standard headrest with surgical cushion
- 3 Swift headrest with oval cushion
- 4 Swift headrest with surgical cushion

13.5.1 Adjusting height of headrest

The height adjustment is identical for the standard and swift headrest. Slide the headrest manually to adjust the headrest height.

CAUTION

When you push the swift headrest towards the backrest, make sure that you are pushing the headrest arm into the backrest and not accidentally tilting up the headrest from the headrest joints.

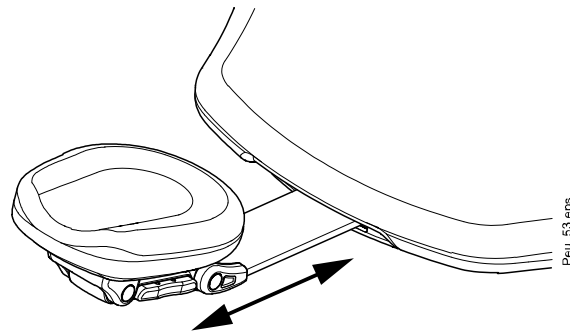

NOTE

The headrest can only be pulled out as far as to the MAX mark.

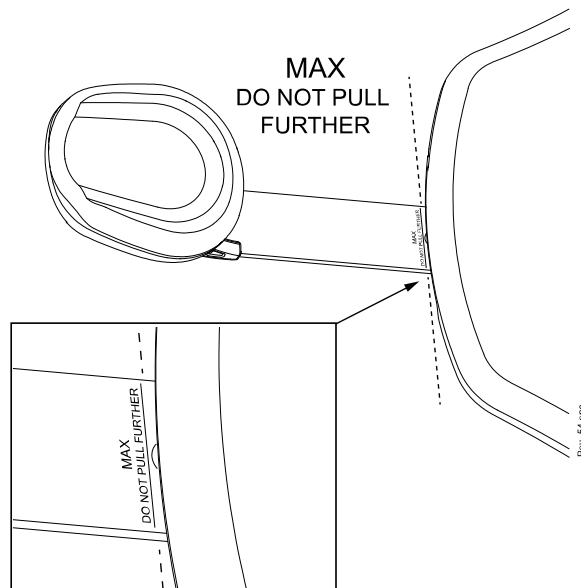

13.5.2 Adjusting headrest angle

NOTE

Support the headrest by hand when you adjust it.

Swift headrest

The swift headrest can be tilted upwards in steps of 8°. A locking mechanism keeps the headrest in place and prevents any downward movement.

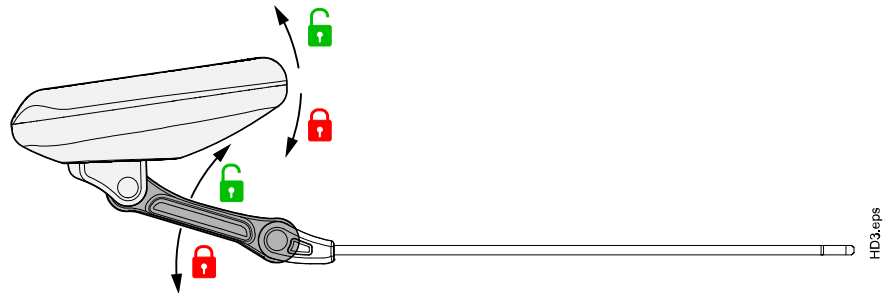

When you press the locking bar (1) on the side of the headrest support, the locking mechanism is released and you can freely adjust the headrest upwards and downwards to the required angle. Release the bar to lock the headrest in the new position.

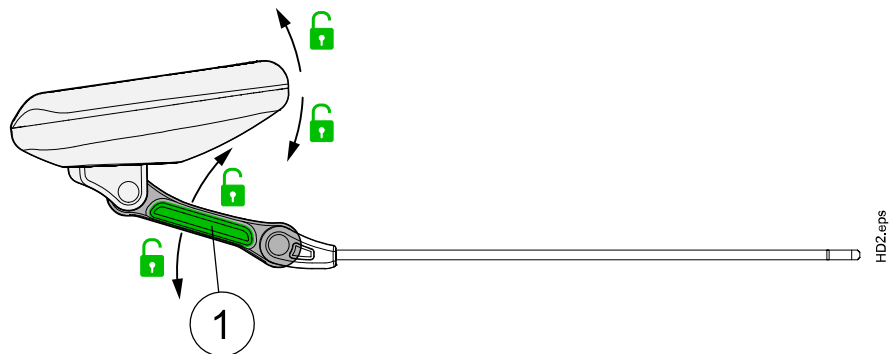

Standard headrest

To adjust the angle of the headrest, press and hold the locking bar (1) on the side of the headrest support to release the locking mechanism. Manually set the headrest to the required angle and release the bar to lock the headrest in the new position.

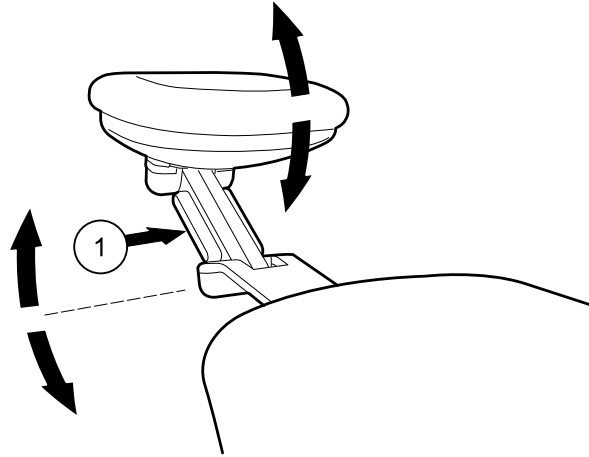

13.5.3 Adjusting headrest for children or short patients

The headrest can be adjusted for better head support for children and short patients.

Swift headrest

NOTE

Never pull out the swift headrest from the backrest and turn it around. A headrest that has been inserted into the backrest upside down may crash under the weight of the patient.

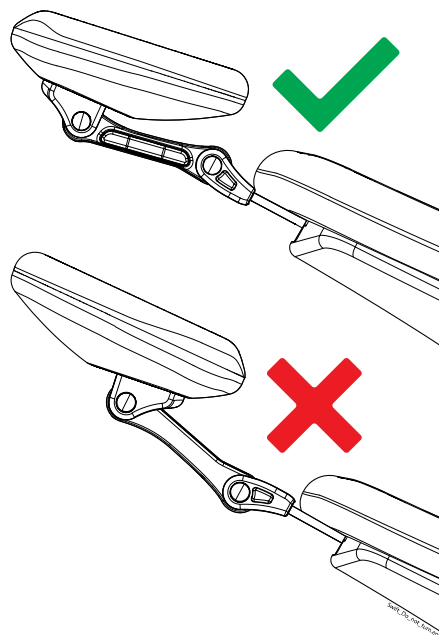

Tilt the headrest up as far as possible so that the cushion faces backwards. Then, turn the headrest around the axis closest to the backrest so that the headrest folds over the backrest. Optionally use a child cushion to support the child better.

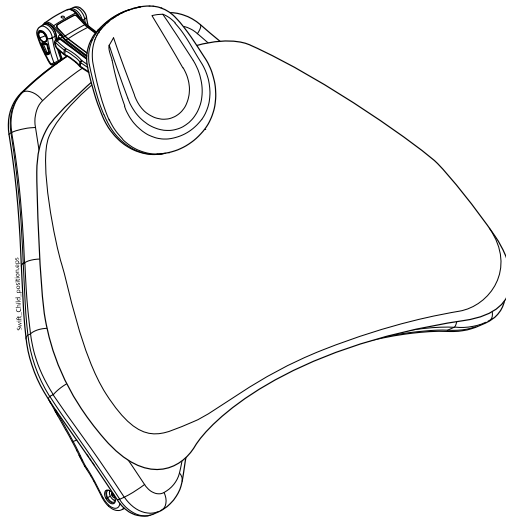

Standard headrest

Pull the headrest out. Turn it around so that the cushion faces backwards and push the headrest back into the chair.

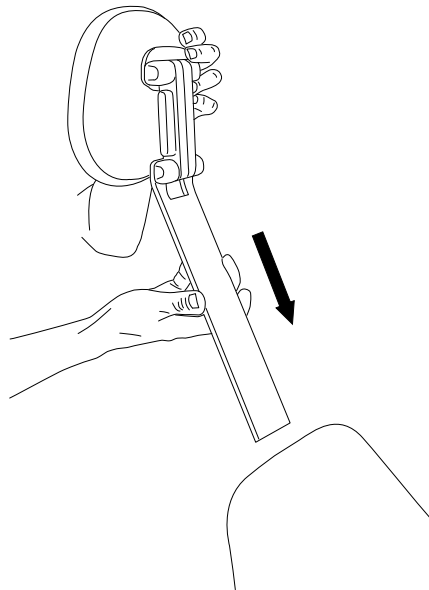

Turn the cushion around (180° counter-clockwise).

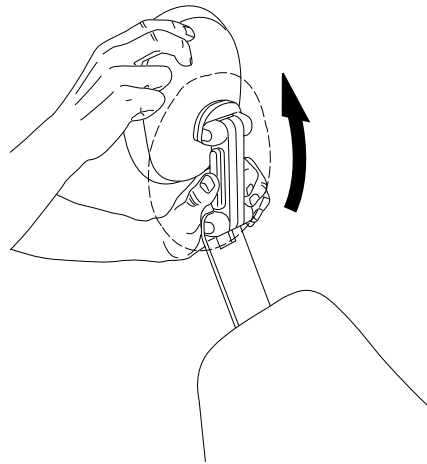

Press the bar on the side of the headrest support to release the locking mechanism and position the headrest at the top of the chair.

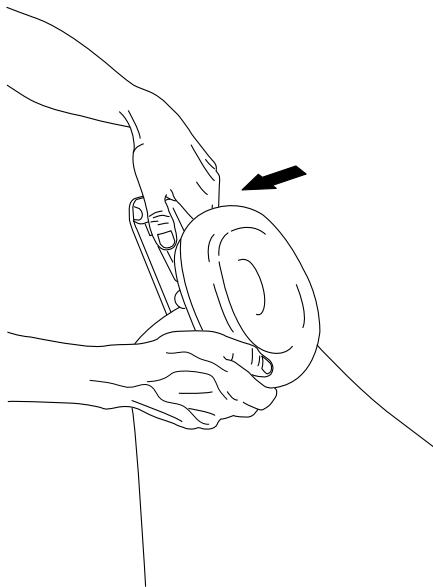

The headrest is now repositioned. To adjust the angle of the headrest, press the locking bar. Manually set the headrest into the required position and release the bar. When adjusting, support the headrest with your other hand.

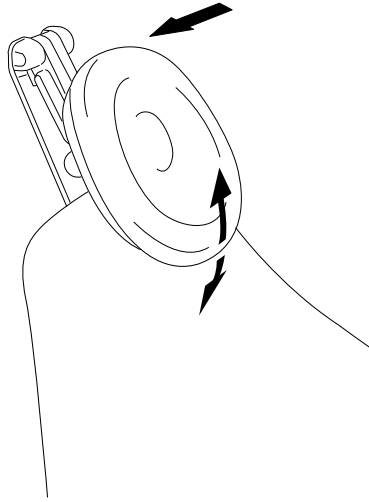

Optionally use a child cushion to support the child better.

14 Control panel

14.1 Control panel on instrument console

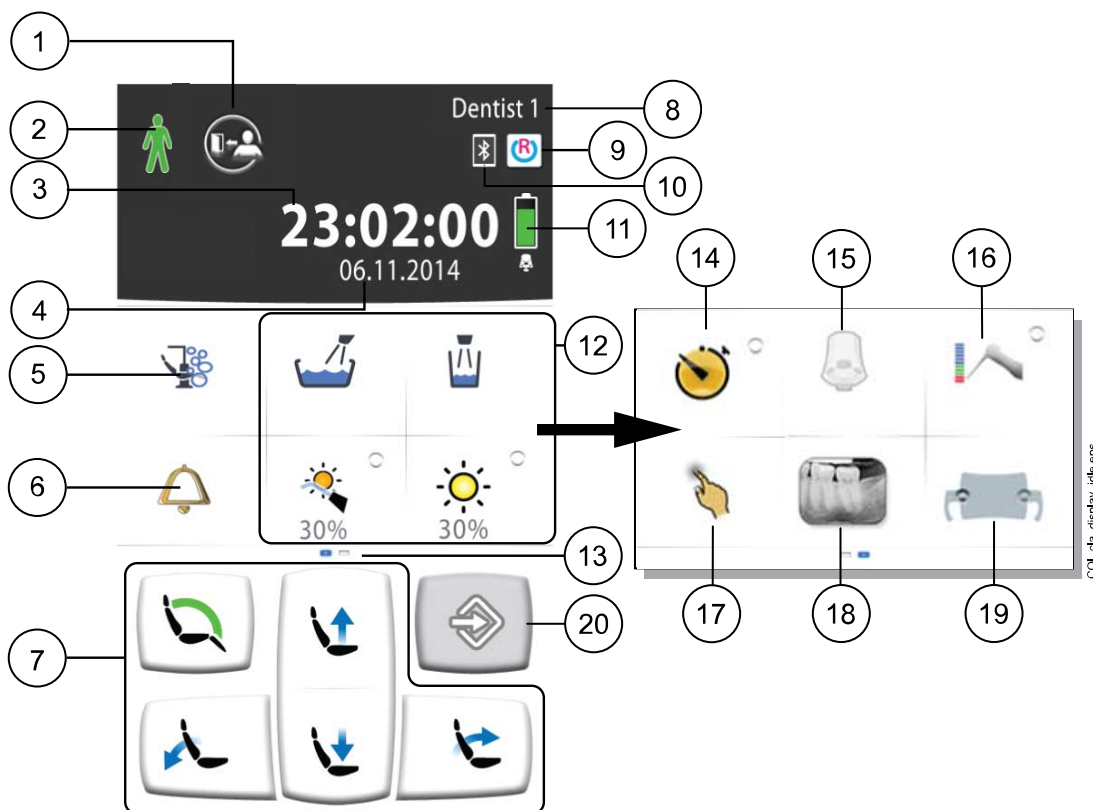

1. Sign out button	11. Wireless foot control battery (optional, display only)
2. Patient recognition (display only)	12. Unit buttons
3. Time (display only)	13. Customisable swipe menu. Swipe to the side to view more functions
4. Date (if configured, display only)	14. Timer button
5. Maintenance button	15. Wireless foot control button (optional)
6. Assistant call / Door open	16. Apex locator button (optional)
7. Chair buttons	17. Touchpad button (optional)
8. User name (display only)	18. X-ray film viewer button
9. Romexis connection (optional, display only)	19. Solanna Vision button (optional)
10. Bluetooth connection enabled (optional, display only)	20. Program button

The control panel is located on the instrument console. You can use it to control and program the instruments, the dental unit, and the chair. You can also start maintenance procedures from the control panel.

You can operate the control panel by touching it with your finger or with a soft stylus. The display is generally medical glove touch capable, but some glove types have limited functionality.

The control panel shows information related to the current operation and changes accordingly.

Some of the buttons have indicator lights that show the status of that specific function. When the indicator light is lit, it means that the function is activated.

When the unit is in programming mode, the **Program** button is blue.

You can organise the items in the main window's swipe menu according to your preferences, see section "Organising items on control panel" on page 175.

The control panel is available in several languages and the language can be changed from the control panel. For more information, see sections "Editing language" on page 86 and "Language" on page 104.



In the programming mode, the setting to be changed is displayed on the control panel. A disabled or unselected function is displayed in grey. To enable or select the function, press the grey button and it will turn blue. A blue button means that the function is enabled or selected.

For more information on programming, see section "Introduction" on page 174.

In case of malfunction, an error code or a help message is displayed, see section "Help and error messages" on page 256.

14.1.1 Touchpad functionality



The control panel can be used as a touchpad. Press the **Touchpad** button on the control panel to open the touchpad-view.

The touchpad-view provides you all the functionalities of a computer mouse and keyboard, so there is no need for an external mouse or keyboard.

NOTE

The touchpad function requires that the dental unit is connected to Planmeca Romexis software. The software version must be 4.1 or later. If there is no Planmeca Romexis connection, the function is disabled and the Touchpad button is grey.

Using control panel as computer mouse



In the touchpad-view, press **Touchpad** to open the mouse-view on the control panel.

Move your finger on the control panel to move the cursor accordingly across the monitor screen. Scroll a list or text with the scroll wheel to the right and use the buttons at the bottom just like you would use the left and right mouse buttons.

A short press of the left and right button clicks an item on the screen. When you press the button for longer, the button stays activated until you release the button by pressing it again. The button is blue when it is activated.

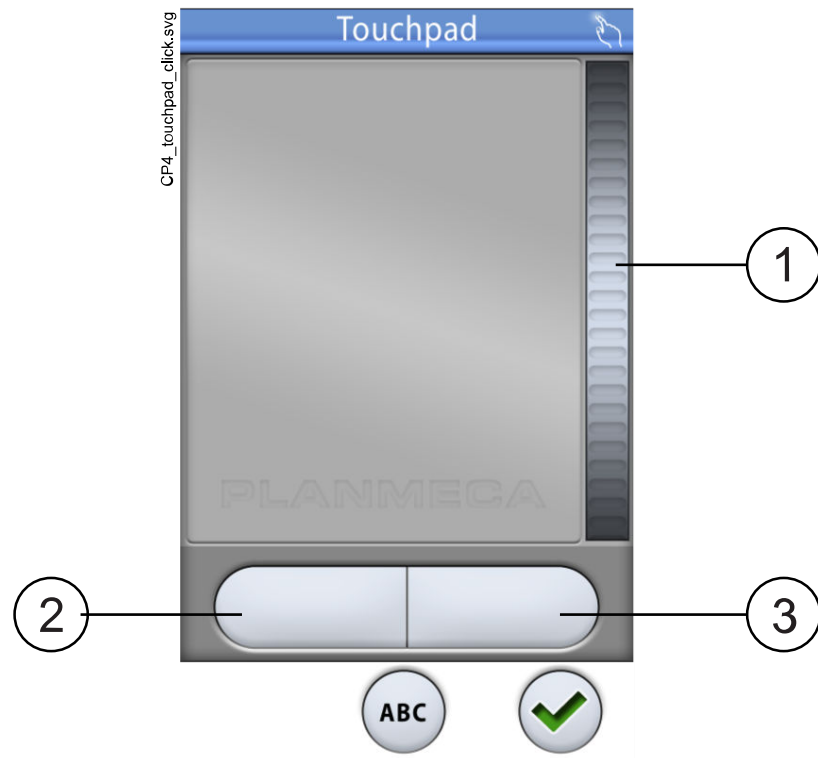

1. Scroll wheel
2. Left button
3. Right button

When you want to exit the touchpad-view, press **OK**.

Example: Drag-and-drop

Use your finger on the touchpad to move the cursor on the screen to the item that you want to drag. When the cursor is on the item, press the left button for 1 second to activate it. The button turns blue. With your finger on the touchpad, drag the item to the correct location. Press the left button to release it (the button turns grey).

Using control panel as keyboard



In the touchpad-view, press **ABC** to open the keyboard on the control panel.

An alphanumeric keyboard is displayed for entering text in a text field on the monitor screen.

Use the arrows in the top row to move up and down, to the left and right in the text.

The symbols below the arrows in the top row can be used as they are, or as a shortcut to letters containing that symbol. For example, when you press **^** for about one second, letters with the symbol **^** are displayed. You will automatically return to the normal view when you enter one of the letters. To return to the normal view without entering a letter, press the symbol again.

To display special characters, press **Alt**. Press **Alt** again to return to the normal view.

14.2 Control panel on Flexy holder

The control panel on the Flexy holder is used for controlling the dental unit and the chair.

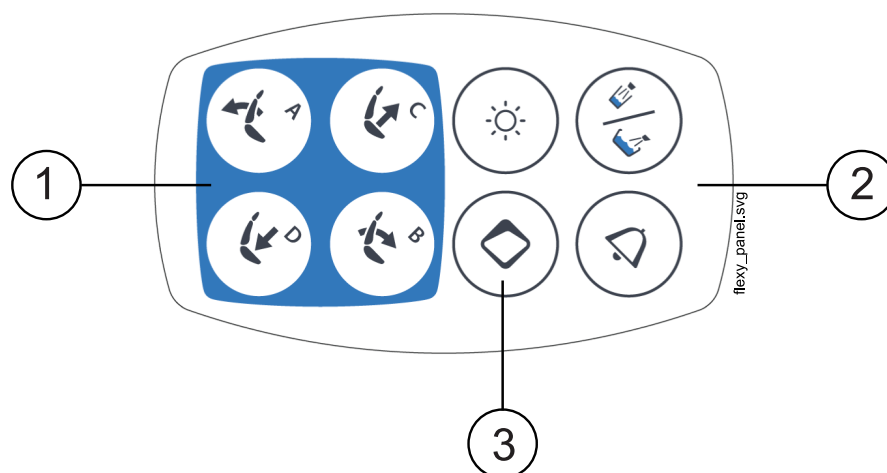

1. Chair buttons
2. Unit buttons
3. Flexy button

The function behind the **Flexy** button can be programmed by the service technician. Depending on what has been programmed, you can do one of the following by pressing the **Flexy** button:

- activate/deactivate the intraoral camera
- drive the chair to the rinsing position (default)
- lock/unlock the touch display
- turn the suction on/off
- turn the operating light's composite mode on/off (short press) or adjust its intensity (long press)
- activate/deactivate the apex locator
- change the light tone of the operating light
- turn Planmeca Solanna Vision video streaming on/off
- start/stop Planmeca Solanna Vision video recording
- capture an image with the Planmeca Solanna Vision camera
- open/close the Planmeca Solanna Vision window.

For more information, contact your Planmeca dealer.

15 Foot control

15.1 Introduction

NOTE

The foot control is IPX1 classified.

The dental unit has one integrated foot control that operates the instruments, the unit and the chair.

The foot control is available as a wireless and a standard version.

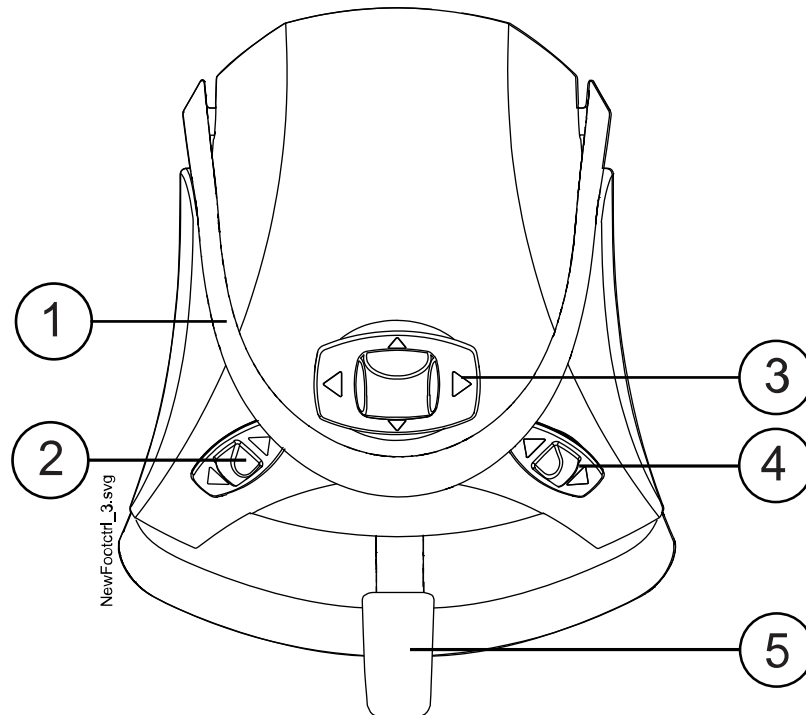

1. Handle
2. Left-side knob
3. Centre knob
4. Right-side knob
5. Pedal

CAUTION

The foot control is a precision instrument. Do not stand on or apply unnecessary force to the foot control and its knobs.

CAUTION

Do not use the foot control in areas where liquids are likely to be present on the floor.

15.2 Foot control pedal

Two foot control pedals are available: a standard pedal (1) and a wide pedal (2).

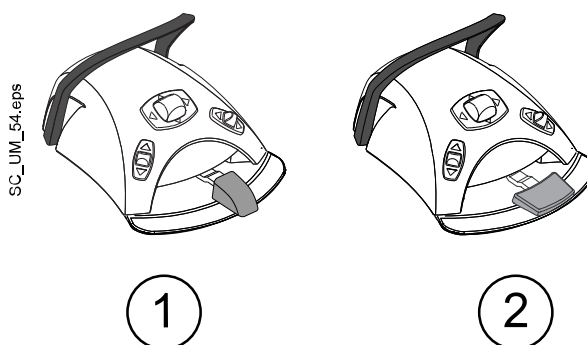

NOTE

If you want to change from a standard pedal to the wide pedal, or vice versa, contact your Planmeca dealer.

The two foot control pedals function differently. For example, to increase the instrument speed, you must push the standard pedal horizontally, either to the left or to the right. When you use the wide pedal, you increase the speed with a vertical movement: the further down you push the pedal, the higher the instrument speed is.

The functional differences between the standard pedal and the wide pedal only apply to the operation of the micromotor, turbine and scaler. They do not apply to the operation of the dental unit or chair. The differences are described in the table below.

Standard pedal vs. wide pedal

Function	Standard pedal	Wide pedal
Increase instrument speed	Push pedal to left/right	Push pedal down
Change instrument spray type	Push pedal down briefly	Push pedal to left
Activate manual chip blow	Push and hold pedal down	Push pedal to right
Activate momentary spray	Push pedal down briefly while driving instrument	N/A

For more information, see sections "Micromotor" on page 126, "Turbine" on page 154, and "Scaler" on page 159.

NOTE

When the functionality of the foot control pedal is different for the standard pedal and the wide pedal, this is clearly indicated in the text and pictures of this manual. When the text refers to the foot control pedal in general without making this differentiation, the same functionality applies to both types of pedal, although the illustration only presents the standard pedal.

15.3 Foot control functions

15.3.1 Centre knob functions

Action	Function
Centre knob left	Chair to automatic position A
Centre knob left, long activation	Backrest down
Centre knob right	Chair to automatic position B
Centre knob right, long activation	Backrest up
Centre knob up	Chair to automatic position C
Centre knob up, long activation	Chair up
Centre knob down	Chair to automatic position D
Centre knob down, long activation	Chair down

15.3.2 Left-side and right-side knob functions

Action	Function
Left-side knob up	Can be configured by a Planmeca service technician. Default function: Operating light on/off
Left-side knob down	Can be configured for a selection of instruments by a Planmeca service technician. The function depends on the selected instrument slot. Only one function per instrument slot can be configured.
Right-side knob up	Can be configured by a Planmeca service technician. Default function: Intraoral camera on/off
Right-side knob down	Chair to rinsing position.

15.3.3 Pedal functions

The factory default functions of the foot control pedal when the dental unit is equipped with a standard pedal and no instrument is activated are presented below.

Action	Function
Pedal left	Assistant call
Pedal down, short activation	Cup fill and bowl rinse
Pedal down, long activation	Cup fill for as long as the pedal is pressed
Pedal right & down	Chair to rinsing position

When an instrument is activated, the functions of the standard pedal depend on the used instrument. These instrument-specific functions are presented below.

Micromotor, turbine

Action	Function
Pedal left / pedal right	Drive instrument
Pedal down, short activation	Change spray water & air / air / off

Micromotor, turbine

Action	Function
Pedal down, long activation	Manual chip blow; activated for as long as the pedal is pushed and held down

Scaler

Action	Function
Pedal left / pedal right	Drive instrument
Pedal down, short activation	Change spray 1 / 2 / off

Unit controlled polymerisation light

Action	Function
Pedal left / pedal right / pedal down	Start / stop instrument

Intraoral camera

Action	Function
Pedal left / pedal right	Freeze / unfreeze picture
Pedal down	Save still picture

Intraoral scanner

Action	Function
Pedal left	Move upward in the list of scan type selection tools
Pedal right	Move downward in the list of scan type selection tools
Pedal down, short activation	Start scanning
Pedal down, long activation	Take image

15.4 Disconnecting standard foot control from dental unit

To disconnect the standard foot control from the dental unit, press down the metallic tongue (1) on the socket and pull out the plug (2).

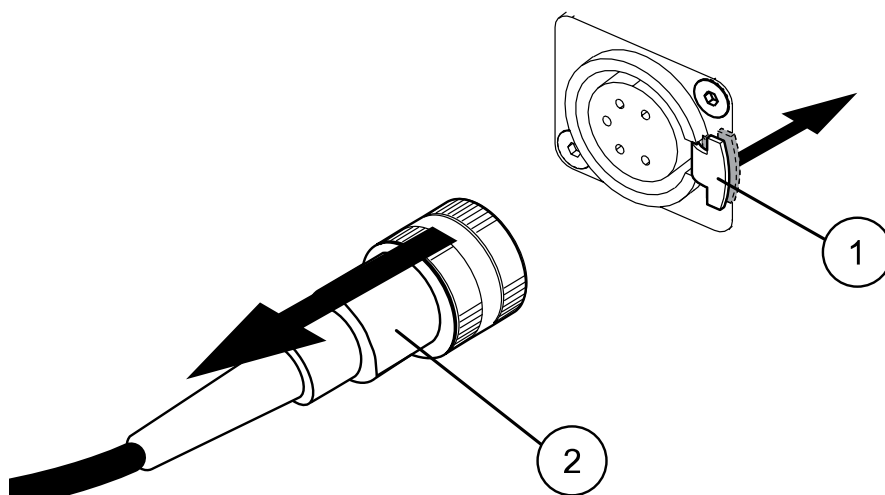

COI_footcontrol_cable.eps

15.5 Wireless foot control



NOTE

The wireless foot control is an optional feature.

The standard foot control and the wireless foot control can not be used simultaneously. Should such a situation occur, the standard foot control overrides the wireless foot control.

When the wireless foot control has been idle for 2 hours, it goes into sleep mode. You are notified about this with a message on the control panel. The sleep mode is also indicated by a battery symbol on the control panel. Wake up the foot control by pressing the foot control handle.

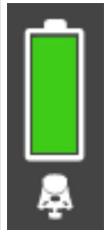
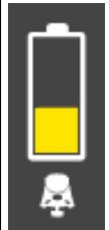
Before using the wireless foot control, check the power level of its battery. The power level is indicated by a battery symbol on the control panel.

Power level	Sleep mode	Full	< 40% full	< 20% full
Symbol				

You can also view detailed battery charging information on the control panel. For instructions, see section "Viewing battery charging information" on page 202.

When the battery is less than 20% full you need to recharge the battery as soon as possible.

To charge the foot control battery, connect the foot control to the power outlet using the provided cable and power adapter. The LEDs on the foot control blink green while the battery is being charged.

When the wireless foot control battery is full, and the foot control is connected to the power outlet, the LEDs on the foot control are a steady green.

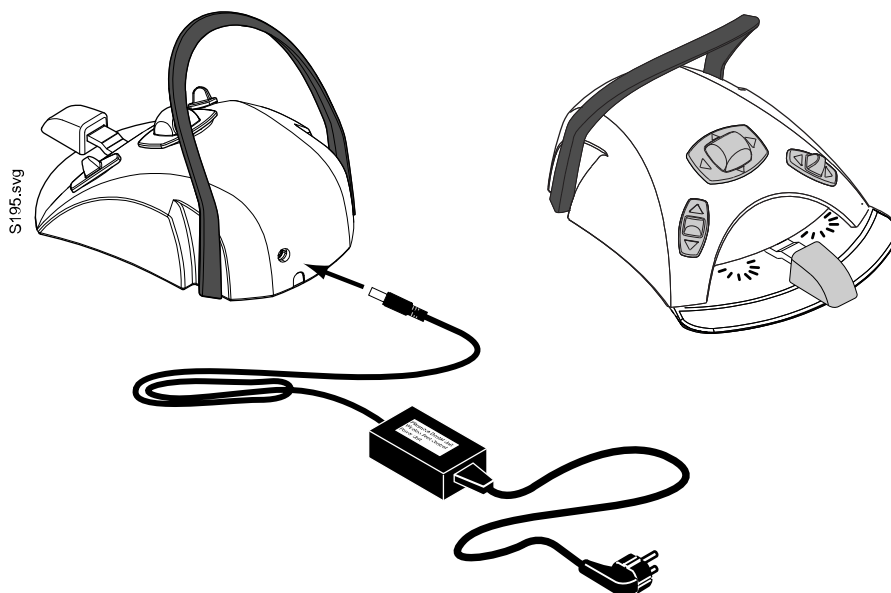

CAUTION

Planmeca supplies two types of power supply for the wireless foot control. Before you charge the foot control battery, check the label on the power supply to ensure whether the battery can be charged while treating a patient.



If the text and general warning sign on the label indicate that charging is prohibited, do not charge the foot control battery while treating a patient.

CAUTION

The battery charging area must be dry. Do not expose the charger to liquids.

NOTE

The power supply is marked and specified as a part of the Planmeca dental unit.

NOTE

The batteries must be replaced only by a qualified Planmeca service technician.

NOTE

The foot control batteries must be removed whenever the foot control is stored for a longer period. The batteries must be removed only by a qualified Planmeca service technician.

NOTE

The wireless foot control transmitter contains a radio device FCC: Y11002 and IC: 9050A-002, and the wireless foot control contains a radio device FCC: Y11001 and IC: 9050A-001. See also section "FCC Class B Notice for wireless foot control" on page 308.

16 Switching unit on and off

The on/off switch (1) is located at the rear of the unit base. Press the switch to turn the unit on. Press the switch again to turn the unit off.

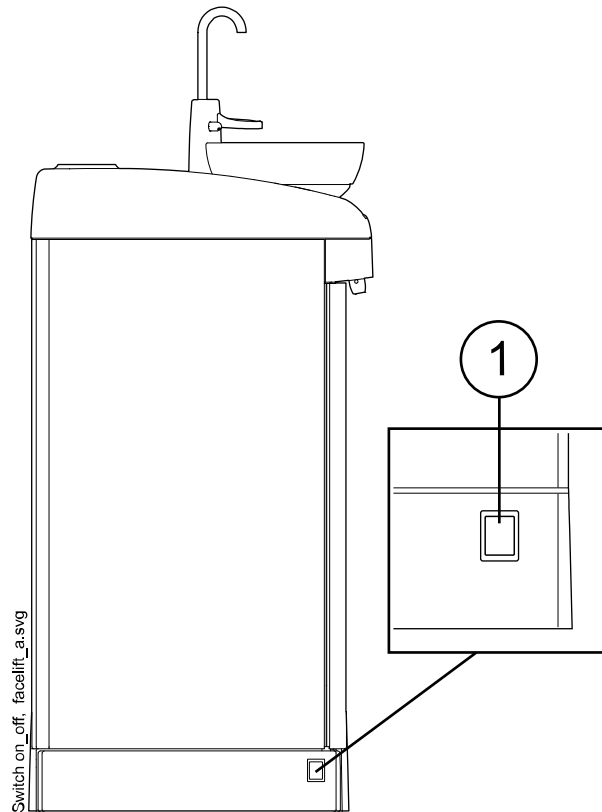

When the unit is switched on, the on/off switch light is on.

NOTE

If your unit is equipped with a water heater, fill the cup once after switching the unit on to start the heating. Notice that when using the water heater, the water temperature can rise up to 46°C.

NOTE

If your dental unit is equipped with the optional Suction Tube Cleaning System (STCS), make sure that the STCS box cover is closed when switching the unit on.

17 Signing in and out

17.1 Signing in

NOTE

The sign in method depends on the dental unit's configuration. For more information on the configuration, or for changing it, contact your Planmeca dealer.

NOTE

Before you can sign in with a PlanID card, you must assign a PlanID card to your user profile. For instructions, see section "Assigning PlanID card to user" on page 90.

If you have a PlanID card and the dental unit is equipped with a PlanID reader, sign in by showing the PlanID card to the PlanID reader on the instrument console.

CAUTION

At least 15 cm of separation distance between the PlanID reader and the user's body must be maintained at all times.

To be able to sign in with your PlanID card, the PlanID connection must be enabled. The connection status is shown in the *Sign in* window.



PlanID is enabled.



PlanID is disabled or PlanID region has not been set.

Instrument console with balanced instrument arms



Instrument console with hanging-tube instruments



If you do not have a PlanID card, you can sign in from the *Sign in* window by pressing on your user name on the list. The list of users can be scrolled.

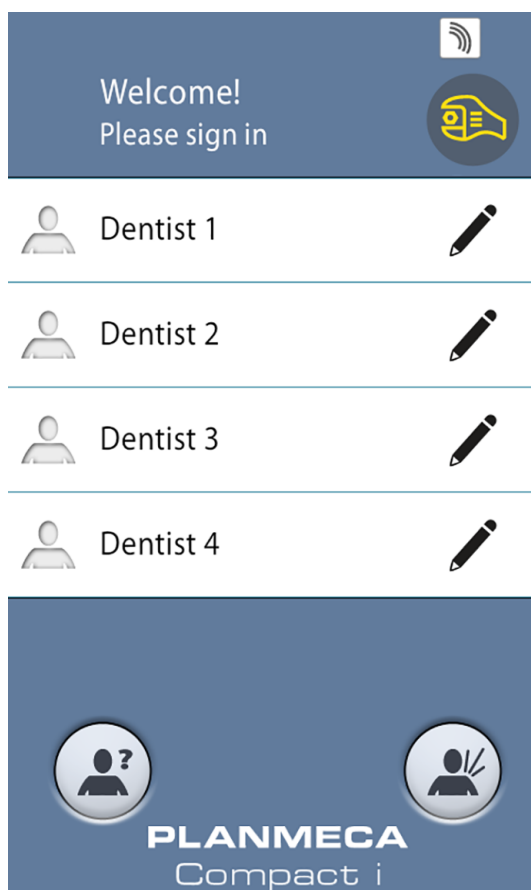

It is also possible to sign in to the dental unit as a guest user by pressing the **Guest user** button in the *Sign in* window.

Once you have signed in, the treatment window opens and you can start using the dental unit with your own personal settings.

Factory settings are loaded for guest users every time they sign in.

17.2 Signing out

Steps



1. In the top left corner of the treatment window, press **Sign out**.

18 Managing users and personal settings

18.1 Introduction

When you sign in to the dental unit, you can start using the unit with your own personal settings. Depending on the dental unit configuration, the settings are either stored in the dental unit or in Planmeca Romexis software. For more information, contact your Planmeca dealer.

Your personal settings include the following:

- user settings (language, colour theme and automatic chair positions view)
- instrument settings
- operating light settings
- chair settings.

For information on how to edit your personal settings, see sections "Editing user settings" on page 84, "Instrument settings" on page 178, "Adjusting intensity of operating light" on page 112, "Automatic chair positions" on page 175, and "Extended vs. traditional view" on page 100.

NOTE

Depending on the dental unit's configuration, some users are not able to edit their user settings. Also, if these users reset their instrument, operating light or chair settings, the reset does not affect the settings that these users may optionally have saved in Planmeca Romexis. For more information, contact your Planmeca dealer.

18.2 Creating new user

About this task

NOTE

If your dental unit includes Planmeca PlanID, create the new user as described in section "Assigning PlanID card to user" on page 90.











Steps



1. Press **New user** in the *Sign in* window.

The *Create new user* window opens.

Create new user

 First name New user	
Last name	
Language: English	
Colour theme: Black	
Assign PlanID tag	
Automatic positions	
	
	

2. Edit the user settings by pressing the **Edit** button.



For information on how to edit the user settings, see section "Editing user settings" on page 84.

18.3 Deleting user

Steps



1. In the *Sign in* window, press **Edit** next to the user that you want to delete.

The *User settings* window opens.

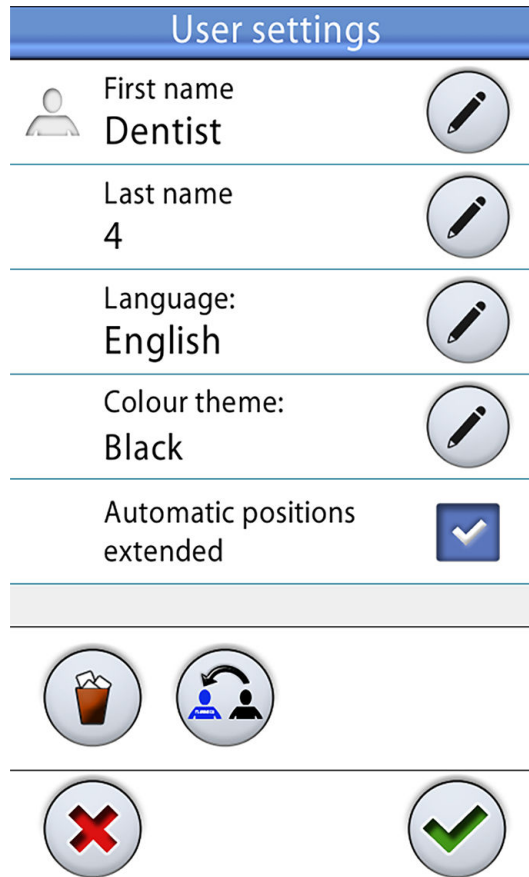

- In the *User settings* window, press **Delete**.



A confirmation message is displayed.

- Confirm the deletion by pressing **OK**.



Your user name is deleted from the user list in the *Sign in* window.

NOTE

The user profile optionally saved in Planmeca Romexis is not deleted. For more information, contact your Planmeca dealer.

18.4 Editing user settings

You can edit the user settings in the *User settings* window. There are two alternative ways to get to this window:

- In the *Sign in* window, press **Edit** next to the user whose settings you want to edit.



- Sign in to the dental unit and press **Program > User settings**.

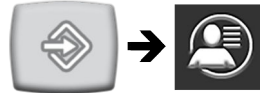

NOTE

If your dental unit has been configured so that you cannot edit your user settings, you can still edit the dental unit's language as described in section "Language" on page 104.

18.4.1 Editing user name

Steps



- In the *User settings* window, press **Edit** next to *First name*.

The *Set first name* window opens.

- Edit your first name.

An alphanumeric keyboard is displayed for editing the user name.



To display special characters, press **ALT**. Press **ALT** again to return to the normal view.

The symbols in the top row can be used as they are, or as a shortcut to letters containing that symbol. For example, when you press **^** for about one second, letters with the symbol **^** are displayed. You will automatically return to the normal view when you enter one of the letters. To return to the normal view without entering a letter, press the symbol again.

3. When you have entered your first name, press **OK** to save the first name and return to the *User settings* window.

Pressing **Close** exits the *Set first name window* without saving the user name.

4. In the *User settings* window, press **Edit** next to *Last name*.



The *Set last name* window opens.

5. Edit your last name.
6. When you have entered your last name, press **OK** to save the last name and return to the *User settings* window.



Pressing **Close** exits the *Set last name* window without saving the user name.

7. When you have edited all the user settings (including language, colour theme and the automatic chair positions view), save them by pressing **OK** in the *User settings* window.

18.4.2 Editing language

About this task

NOTE

If your dental unit has been configured so that you cannot edit your user settings, you can still edit the dental unit's language as described in section "Language" on page 104.

Steps



1. In the *User settings* window, press **Edit** next to *Language*.

The *Program - Language* window opens.

2. Edit the used language.

Select your preferred language from the list by pressing on the language. You can scroll the list of languages either from the list itself, from the scroll bar to the right, or by using the **Up** and **Down** buttons.

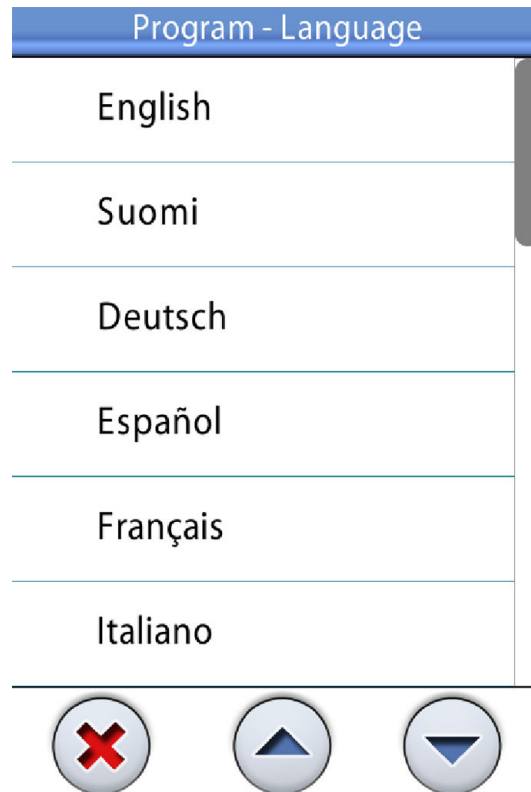

When you press a language to select it, you will automatically return to the *User settings* window.

Pressing **Close** exits the *Program - Language* window without making changes to the language.

The available languages are:

- English
- Finnish
- German
- Spanish
- French
- Italian
- Swedish
- Hungarian
- Czech
- Danish
- Norwegian
- Russian
- Japanese
- Polish
- Traditional Chinese
- Simplified Chinese

- Romanian
- Arabic
- Dutch
- Portuguese
- Greek
- Turkish
- Estonian
- Latvian
- Lithuanian



3. When you have edited all the user settings (including user name, colour theme and the automatic chair positions view), save them by pressing **OK** in the *User settings* window.

18.4.3 Editing colour theme

Steps



1. In the *User settings* window, press **Edit** next to *Color theme*.

The *Program - Theme* window opens.

2. Edit the used colour theme.

Select your preferred colour theme from the list by pressing on the colour. You can scroll the list of colour themes either from the list itself, from the scroll bar to the right, or by using the **Up** and **Down** buttons.

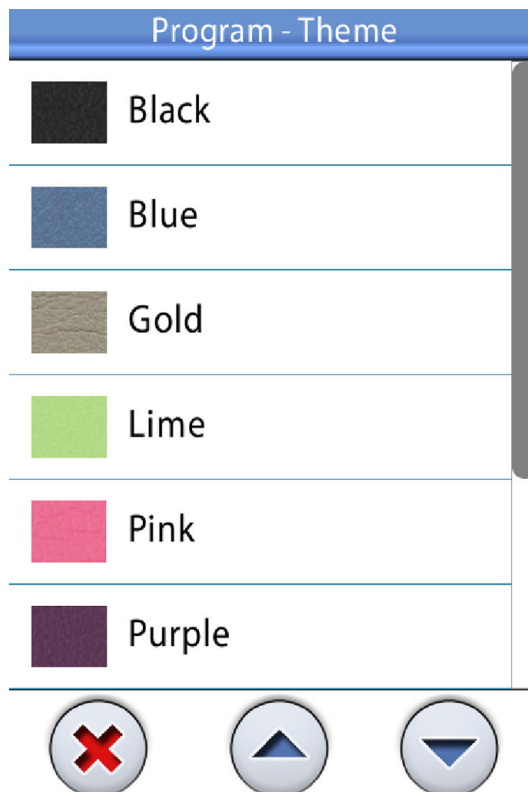

When you press a colour to select it, you will automatically return to the *User settings* window.

Pressing **Close** exits the *Program - Theme* window without making changes to the colour theme.



- When you have edited all the user settings (including user name, language and the automatic chair positions view), save them by pressing **OK** in the *User settings* window.

18.5 Resetting personal settings

About this task

You can reset your personal settings (language, colour theme, instrument, operating light and chair settings) to factory defaults. The reset does not affect your user name or your position on the user list in the *Sign in* window.

NOTE

[This reset only applies to settings stored in the dental unit. For more information, contact your Planmeca dealer.](#)

Steps

- Open the *User settings* window.

There are two alternative ways to open this window:



In the *Sign in* window, press **Edit** next to the user whose settings you want to reset.

OR

Sign in to the dental unit and press **Program > User settings**.

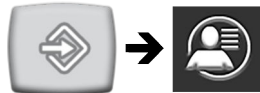

The *User settings* window opens.

- Press **Reset**.



A confirmation message is displayed.

- Confirm the reset by pressing **OK**.



19 Assigning PlanID card to user

Before you begin

Prerequisites:

- Planmeca Romexis version 4.6 or later installed
- Dental unit is connected to the Planmeca Romexis server
- Dental unit's PlanID reader has been enabled by a qualified Planmeca service technician.

For information on the dental unit's configuration requirements, contact your Planmeca dealer.

Before you assign the PlanID card to a user, we recommend that the user has been created in the Admin module of Planmeca Romexis. This is typically done by a Planmeca Romexis administrator.

The following information must be supplied when creating the user:

- In *Add User* window, *User* tab
 - Username
This username is later entered in the Romexis username field in the dental unit.
 - Member of Groups
We recommend that you create a group for PlanID users and add all PlanID users to that group.
- In *Add User* window, *Personal* tab
 - First Name
 - Last Name

These will be shown in the dental unit as your first and last name.

NOTE

If you have stored a picture of yourself in Planmeca Romexis software, the picture will show in the dental unit's *User settings* window and in the Welcome-message that is displayed when you sign in to the dental unit.

For instructions, see *Planmeca Romexis technical manual*, chapter *Administration*, section *Resource*.

About this task

Before you sign in to the dental unit with the PlanID card for the first time, you must assign the PlanID card to the user. This can be done either from the dental unit or from the Planmeca Romexis computer.

Especially if you must assign PlanID cards for several users, we recommend that you assign them from the Planmeca Romexis computer. For instructions, see *Planmeca PlanID quick guide* (30005120).

The following instructs how to assign the PlanID card from the dental unit.





Steps





1. Press **New user** in the *Sign in* window.

The *Create new user* window opens.

Create new user

	First name New user	
	Last name	
	Language: English	
	Colour theme: Black	
	Assign PlanID tag	

Automatic positions 









2. Press **Assign PlanID tag**.

The *Assign PlanID tag* window opens.

Assign PlanID tag

Enter either an existing Romexis username or a new username.

Romexis username: 

Waiting for PlanID tag.







3. Press **Edit** next to *Romexis username*.

The *Set Romexis username* window opens.



4. Enter your Romexis username and save the changes by pressing **OK**.

The username must be the same that you entered in the *Add User* window in Planmeca Romexis.

Only letters A-Z and a-z, period (.), hyphen (-), underscore (_) and the "at" sign (@) are allowed.

The *Set Romexis username* window closes.

5. Show the PlanID card to the PlanID reader on the dental unit.

The text *PlanID tag detected* is displayed.



6. Close the *Assign PlanID tag* window by pressing **OK**.

7. Close the *User settings* window by pressing **OK**.

Results

Your PlanID card has now been assigned to you and you have been signed in to the dental unit.

20 Checking dental unit details

20.1 About this unit

About this task

The technical details about the dental unit are presented in the *About this unit* window.

This section describes how to access the *About this unit* window and the subsequent sections describe what information you can find in this window.

Steps



1. Press **Program**.



2. Press **About this unit**.

The *About this unit* window opens.

NOTE

The following is an example only and does not necessarily portray the actual situation.

About this unit	
Unit type	Compact i v2
Unit serial number	UTTF123456
Unit SW version	7.11.0.302.B >
Service	>
Network settings	10.0.0.146 >
Message history	>
Bluetooth	>
Licences	>
Designed and Assembled by Planmeca in Finland	

> means that more information can be opened to a new window.



3. Press **OK** to close the window.

20.2 Unit type

Unit type tells you which type of dental unit you are working on.

20.3 Unit serial number

Unit serial number shows the serial number of your dental unit. If the dental unit's main control PCB is not equipped with a software licence dongle, no serial number is displayed.

20.4 Unit software version

Unit SW version shows the software version.

Press > to display detailed information on the different parts of the software.

20.5 Service

Service contains information for service situations.

Press > to display the following items:

- *Service contact details*
- *Annual maintenance*
- *Storage information*
- *GUI diagnostics*
- *PlanID*
- *Clock calibration*
- *Product registration*
- *Peripherals*
- *Dental unit model*
- *Screensaver*

20.5.1 Service contact details

The service contact details give you information on whom to contact when you need technical assistance. The contact information can only be edited by a qualified Planmeca service technician.

20.5.2 Annual maintenance

Annual maintenance tells you

- when the annual maintenance was last performed
- how many days are left until the next annual maintenance.

The last item, *Confirm annual maintenance*, is for qualified Planmeca service technicians only.

20.5.3 Storage information

Storage information contains details on the control panel SD card.

Press > to display the relevant information.

20.5.4 GUI diagnostics

GUI Diagnostics shows the current hardware revision of the control panel and also contains tools for finding possible errors in the touch display.

CAUTION

GUI diagnostics is only meant to be used by a qualified Planmeca service technician.

20.5.5 PlanID



In the *Details* tab you can view details on the tag ID and the PlanID reader's region of operation. To change the region, contact your Planmeca dealer.

CAUTION



The *Configuration* tab contains tools for enabling/disabling the PlanID reader as well as for adjusting its power level, and is only meant to be used by a qualified Planmeca service technician.

20.5.6 Clock calibration

For instructions on how to calibrate the clock, see section "Calibrating clock" on page 204.

20.5.7 Product registration

For instructions on how to register your dental unit, see section "Registering your product" on page 6.

20.5.8 Peripherals

Peripherals contains information on and service tools for:

- Solanna operating light
- Capacitive patient sensor (Capsense)

CAUTION

The tools for the Solanna operating light and the capacitive patient sensor are only meant to be used by a qualified Planmeca service technician.

20.5.9 Dental unit model

Dental unit model shows the model of your dental unit.

20.5.10 Screensaver

It is possible to configure the dental unit so that a screensaver is displayed when the *Sign in* window has been unused for 3 minutes. To take a standard or custom screensaver into use, contact your Planmeca dealer.

20.6 Network settings

The front page of *About this unit* shows the dental unit's IP address next to *Network settings*. Press > to display the dental unit's network settings.



Press the *Romexis* tab to view network settings related to the Planmeca Romexis connection.

The following network settings are displayed:

- Romexis connection
- Name of dental unit
- MAC address
- DHCP
- IP address
- Network mask
- Gateway
- Romexis server IP address
- Romexis server port
- Communication protocol



Press the *Solanna Vision* tab to view network settings related to the Planmeca Solanna Vision operating light.

The following network settings are displayed:

- DHCP
- MAC address
- IP address
- Network mask
- Gateway



The Planmeca Solanna Vision camera settings (user credentials, stream resolution, frame rate and microphone) can be reset to factory defaults by pressing the **Reset** button, but reset must only be performed by a qualified Planmeca service technician.

CAUTION

The network settings may only be edited by a qualified Planmeca service technician.

20.7 Message history

Message history displays help and error messages when you press >.

For information on how to use the message log, see section "Viewing help and error message history" on page 257.

20.8 Bluetooth

When you press > next to *Bluetooth*, you are directed to a window where you can enable or disable the Bluetooth connection.

20.9 Licences

Licences displays the licences used by the dental unit when you press >.

21 Operating patient chair

21.1 Manual operation

CAUTION

When driving the chair near the upper limit, make sure that the console arm does not press or hit the patient.

CAUTION

When driving the backrest up, make sure that the patient's hand or arm does not get squeezed between the armrest and the backrest.

To drive the backrest down, press the **Backrest down** button until the chair reaches the required position.

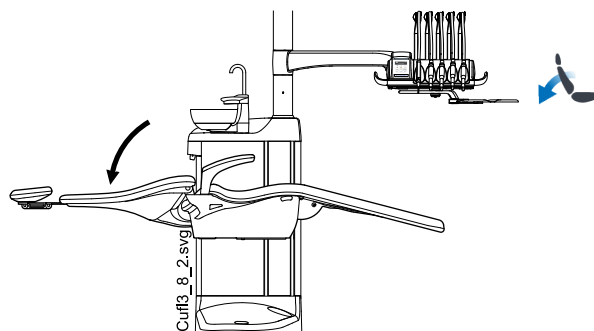

NOTE

If the chair is equipped with an optional automatic legrest, the legrest position is adjusted simultaneously with the backrest position.

To drive the backrest up, press the **Backrest up** button until the chair reaches the required position.

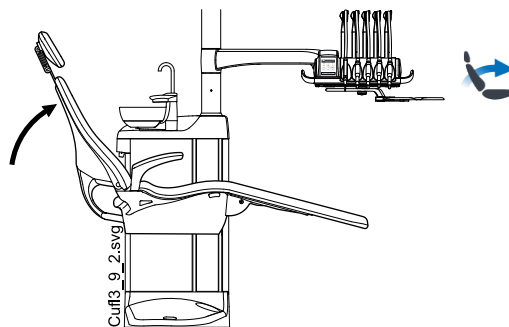

To drive the chair up, press the **Chair up** button until the chair reaches the required position.

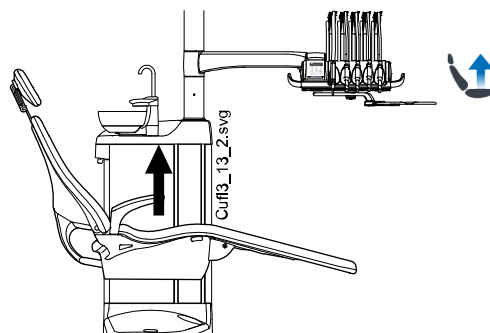

NOTE

Make sure that the bowl or cuspidor tray is not above the patient chair when driving the chair up.

NOTE

If the chair is equipped with the chair-mounted left/right suction arm, make sure that the Flexy holder does not hit the cuspidor when driving the chair up.

To drive the chair down, press the **Chair down** button until the chair reaches the required position.

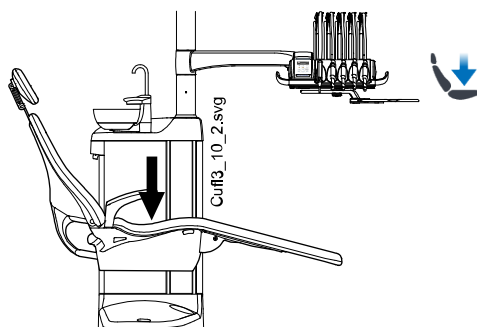
**NOTE**

If your chair is equipped with an optional automatic legrest, the lowest possible position of the chair depends for safety reasons on the legrest position.

NOTE

In case the chair is equipped with the chair-mounted left/right suction arm, make sure the Flexy holder is not above the cuspidor when driving the chair down. If the chair does not move downward and H 03 is displayed, check that the chair-mounted arm is not in the upmost position. This arm position prevents the chair from moving downward.

Alternatively, you can adjust the position of the chair with the foot control. Push and hold the centre knob in the desired direction (see picture below). When the chair reaches the desired position, release the centre knob. You can steer the chair only in one direction at a time.

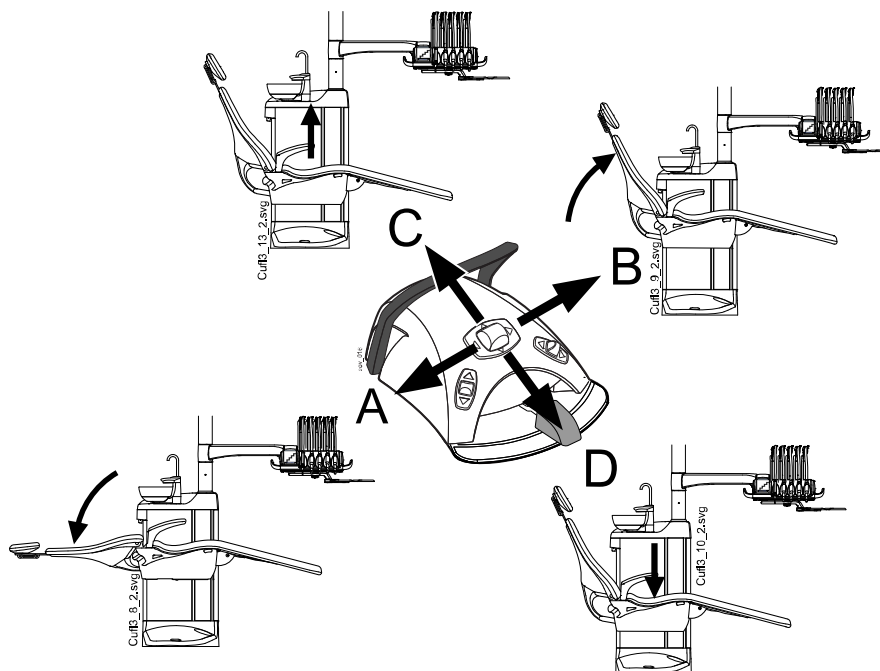

21.2 Automatic operation

21.2.1 Overview

Automatic chair positions can be stored into memory.

For more information on how to store the automatic positions, see section "Automatic chair positions" on page 175.

When automatic positions have been stored into memory you can select an automatic position from the control panel or the foot control and the chair automatically drives to the selected position. When the chair has reached its preprogrammed position, the position can be adjusted. To adjust the position manually, use the foot control's centre knob or the chair positioning buttons on the control panel in a non-automatic mode (see section "Manual operation" on page 97).









You can program the operating light and its composite mode to be on or off in preprogrammed positions. The light goes off when the chair begins to move to a position where the light has been programmed to be off, but goes on only after the chair has reached the programmed position, where the light has been programmed to be on. The operating light and composite mode intensities can also be programmed to a certain value.

NOTE

If the chair is equipped with the chair-mounted left/right suction arm, make sure the Flexy holder is not above the cuspidor when driving the chair down. If the chair does not move downward and H 3 is displayed, check that the chair-mounted arm is not in its upmost position. This arm position prevents the chair from moving downward.

21.2.2 Extended vs. traditional view

In the *User settings* window, select whether you want to view the automatic positions in a traditional or an extended view.

User settings	
 First name Dentist	
Last name 1	
Language: English	
Colour theme: Black	
Automatic positions extended	<input checked="" type="checkbox"/>
	
 	

- **Extended view**
Includes the automatic positions A, B, C, D and rinsing position in list-format and allows renaming of positions A - D. For instructions, see section "Extended view" on page 176.
To take the extended view into use, check the checkbox next to *Automatic positions extended* in the *User settings* window.
- **Traditional view**
Includes the automatic positions A, B, C, D and rinsing position.
To take the traditional view into use, uncheck the checkbox next to *Automatic positions extended* in the *User settings* window.

21.2.3 Selecting automatic position

Extended view



Control panel: To move the chair to a preprogrammed position, first press the **Chair positions** button in the main window. Then, in the list that opens, select an automatic position by pressing it.

The position you are currently in is marked by a blue frame.

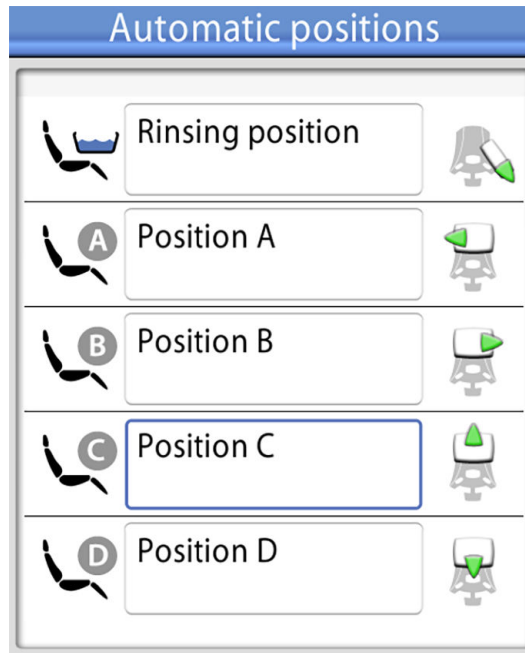

Foot control: A foot control symbol on the right side of the automatic position on the list indicates in which direction you must push the right-side or centre knob to drive the chair to the preprogrammed automatic position.

For information on how to adjust the preprogrammed automatic positions, see section "Extended view" on page 176.



When the chair is in an automatic position, the current position is displayed on the **Chair positions** button in the main window.

Traditional view

Control panel: To move the chair to a preprogrammed position, press briefly the corresponding chair position button.

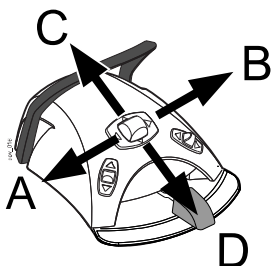
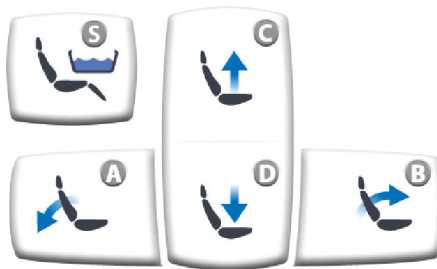

Foot control: Push the centre knob briefly to the position (A, B, C or D) where the preprogrammed chair position has been stored. The chair will move automatically to the preprogrammed position.

21.2.4 Selecting rinsing position

Extended view



When the chair moves to the rinsing position, the bowl on the **Chair positions** button flashes throughout the movement. Filling the cup starts automatically and the bowl is rinsed.

When the chair stops in the rinsing position, the bowl symbol on the **Chair positions** button stops flashing.



To return to the previous working position, press **Chair positions** again and select *Working position* from the list that opens. Bowl rinsing starts automatically. An arrow on the button flashes throughout the movement. When the chair stops, the operating light turns back on, if it was on initially.

Standard view



Press **Rinsing position** to move the chair to the preprogrammed rinsing position. The indicator light flashes throughout the movement. Filling the cup starts automatically and the bowl is rinsed.



When the chair stops in the rinsing position, the indicator light remains on and an arrow appears below the indicator light.

When you press **Rinsing position** again, the chair will return to the previous working position. Bowl rinsing starts automatically. The indicator light flashes throughout the movement.

Foot control

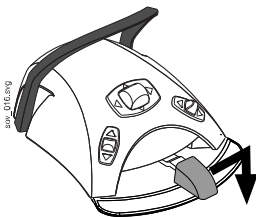

You can drive the chair to the rinsing position by pushing the pedal to the far right and down.

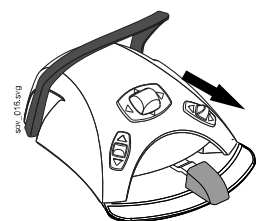

You can also drive the chair to the rinsing position with the foot control by pushing down the right-side knob.

To return to the working position, push down the right-side knob again.

For information on how to program the rinsing position, see section "Automatic chair positions" on page 175.

NOTE



Alternatively, the dental unit can be configured so that the chair moves to the preprogrammed rinsing position when you press the Flexy button. Contact your Planmeca dealer.

NOTE

The unit can be set up so that the Rinsing position indicator light goes off and the previous position is not stored when you are driving from the rinsing position to a preprogrammed position. Next time you press Rinsing position, the chair will move to the rinsing position. Contact your Planmeca dealer.

NOTE

Automatic cup fill and bowl rinse functions when the dental unit reaches the rinsing position are configurable; contact your Planmeca dealer.

NOTE

The water in the dental unit is intended for rinsing only, not for drinking.

21.2.5 Stopping chair movements

To stop the chair from moving before it reaches the preprogrammed position, either press anywhere on the control panel display, press any chair button on the Flexy holder, push the foot control pedal or the centre knob in any direction, or press the foot control handle.

The chair movement stops also when the stop plate is pushed or when the backrest is pressed upward. The chair can be driven normally after the possible obstruction has been removed.

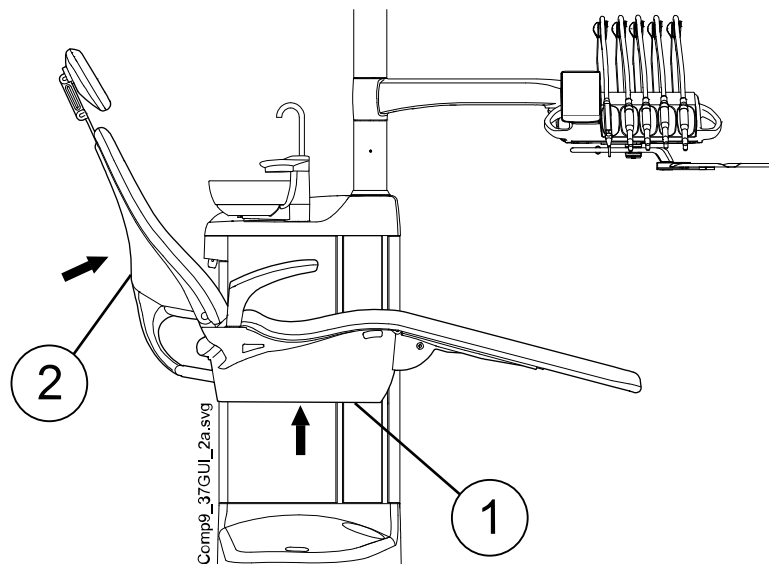

1. Stop plate
2. Backrest

22 Operating dental unit

22.1 Language

About this task

If your dental unit has been configured so that you can not edit your user settings, including language, you can edit the dental unit's language as described below.

NOTE

Users who can edit their user settings change the language as described in section "Editing language" on page 86.

Steps



1. Press **Program**.



2. Press **Language** to open a list of available languages.

The available languages are:

- English
- Finnish
- German
- Spanish
- French
- Italian
- Swedish
- Hungarian
- Czech
- Danish
- Norwegian
- Russian
- Japanese
- Polish
- Traditional Chinese
- Simplified Chinese
- Romanian
- Arabic
- Dutch
- Portuguese
- Turkish
- Greek

- Latvian
 - Lithuanian
 - Estonian
3. Select a language by pressing it.
Move up and down on the list by pressing the up/down buttons.
The list of languages closes and the language of your choice is displayed on the control panel.

22.2 Bowl rinse



Control panel on instrument console: Press **Bowl rinse** to rinse the bowl. Bowl rinsing can be stopped before it stops automatically by pressing **Bowl rinse** again.



Control panel on Flexy holder: Press **Cup fill / Bowl rinse** to rinse the bowl. Bowl rinsing can be stopped before it stops automatically by pressing **Cup fill / Bowl rinse** again.

The flow rate of the bowl rinse can be adjusted by turning the black knob inside the unit, see section "Adjusting cup fill and bowl rinse flow rates" on page 192.

The duration of bowl rinsing can be programmed, see section "Duration of bowl rinsing" on page 193.

22.3 Cup fill

NOTE

By default, the cup fill is not activated unless the cup is positioned in its place under the cup fill tube. To change this setting, contact your Planmeca dealer.

NOTE

The water in the dental unit is intended for rinsing only, not for drinking.



Control panel on instrument console: Press **Cup fill** and the unit will automatically fill the cup and then rinse the bowl. Cup filling can be stopped before it stops automatically by pressing **Cup fill** again.

If **Cup fill** is pressed and held for longer than 1 second, water flows for as long as the button is pressed, and the bowl is not rinsed.



Control panel on Flexy holder: Press **Cup fill / Bowl rinse** twice or press the button once until the cup filling starts (0.5 - 1 sec.) and the unit will automatically fill the cup and then rinse the bowl. Cup filling can be stopped before it stops automatically by pressing **Cup fill / Bowl rinse** again.

If **Cup fill / Bowl rinse** is pressed and held for longer than 1 second, water flows for as long as the button is pressed, and the bowl is not rinsed.

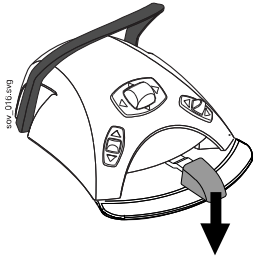

Foot control: When all the instruments are in their holders you can fill the cup either by briefly pushing the pedal down twice or by pushing down the pedal once until the filling starts (0.5 - 1 sec.). The unit will automatically fill the cup and then rinse the bowl. Cup filling stops automatically after a preset time. Cup filling can be stopped before it stops automatically by pushing the pedal briefly down.

If the pedal is pushed for longer than 1 second, water flows for as long as the pedal is pushed, and the bowl is not rinsed.

The flow rate of the cup fill can be adjusted by turning the black knob inside the unit, see section "Adjusting cup fill and bowl rinse flow rates" on page 192.

The duration of the cup fill can be programmed, see section "Duration of cup filling" on page 193.

Patient's cup fill button (optional)

The patient can fill the cup by pressing the patient's cup fill button on the cuspidor. The water flows for as long as the button is pressed.

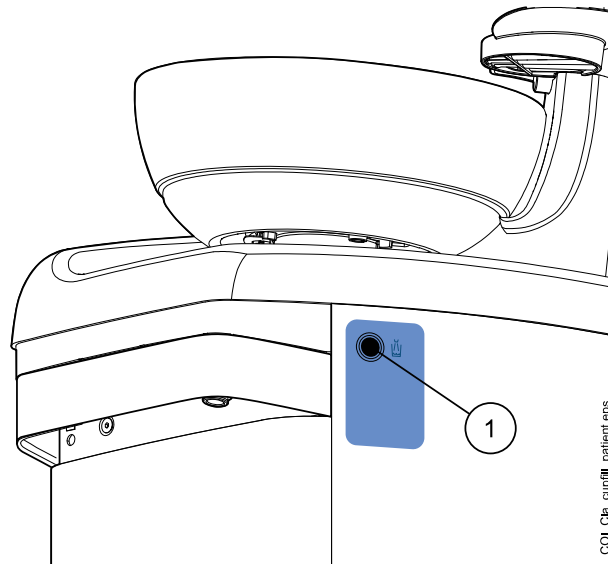

1 Patient's cup fill button

22.4 Timer

About this task

The timer memory contains six preprogrammed time settings. Follow the steps below to activate a timer.

NOTE

Other functionalities can be used while the timer is running.

NOTE

The timer can not be run from the foot control.

Steps

1. Press **Timer** to open a list of available timers.

2. Select a timer from the list.

The **Timer** button's indicator light is lit and the duration of the timer is displayed on the control panel. The countdown begins immediately, but the selected time is displayed for five seconds before the actual countdown is displayed.



If you wish to close the list without selecting a timer, press **Close**.

Results

When the timer reaches zero you will hear two signal tones and the indicator light goes off.

The function can be cancelled by pressing **Timer** again.

The preset timers can be reprogrammed, see section "Timer settings" on page 191.

22.5 Door open / assistant call

If you have installed a door opening device or assistant call, you may activate these from the control panel or the foot control.

NOTE

Only one of these functions can be enabled at a time. To change the enabled function, contact your Planmeca dealer.



Control panel: Press **Door open / assistant call** to activate the function. You will hear a short signal tone when the function starts.

Press **Door open / assistant call** for longer than 0.5 seconds to continue the function until the button is released.

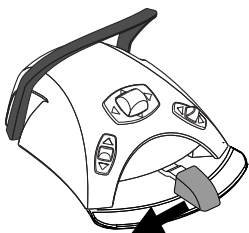

Foot control: When all the instruments are in their holders you can push the pedal to the left to activate the Door open / assistant call function. If the pedal is pushed for longer than 0.5 seconds, the function continues for as long as the pedal is pushed.

NOTE

Alternatively, the foot control can be configured so that the Door open / assistant call function is activated when you push the left-side or right-side knob up. Contact your Planmeca dealer.

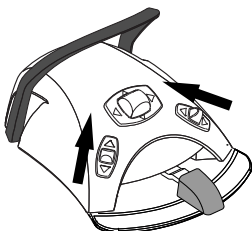

The duration of the signal can be programmed, see section "Duration of door open / assistant call" on page 197.

22.6 Planmeca Solanna and Planmeca Solanna Vision operating light

CAUTION

Do not allow the patient to grab the operating light or its arm when getting seated or getting up from the patient chair.

NOTE

The light must be moved from the handles only. Do NOT move the light from the arm or from the light body.

NOTE

The light beam may speed up the hardening of some filling materials. Move the light so that the light beam is not directed towards the filling material or turn on the operating light's composite mode.

NOTE

To be able to use the operating light hands-free with the gesture sensor, the sensor must be enabled.

NOTE

The sensor detects your hand movement at an approximate distance of 3 - 18 cm (1.2 - 7.1 in.) from the infrared sensor.

The distance can be adjusted, see section "Gesture sensor" on page 196.

22.6.1 Indicator lights



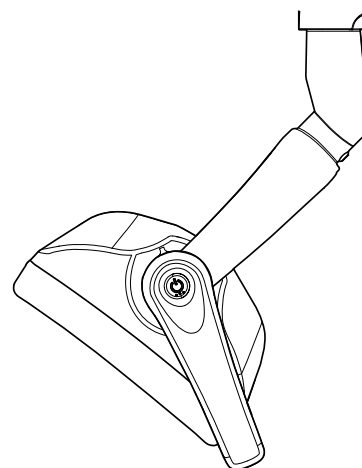

The indicator lights on the operating light's handle buttons indicate the current state of the operating light.



Indicator lights

Colour	Meaning
White 	The operating light is on and the colour temperature is neutral.

Indicator lights

Colour	Meaning
Light blue 	The operating light is on and the colour temperature is cool.
Peach 	The operating light is on and the colour temperature is warm.
Orange 	The composite mode is on.
Green 	The operating light is off.
Yellow 	The operating light is not functioning properly and full luminosity can not be reached. A warning sound is heard. Please contact your local Planmeca service technician.

22.6.2 Switching operating light on/off

From operating light

From one handle

Briefly press the handle button on either handle to switch the light on. Press the handle button a second time to switch the light off.

You will hear a clicking sound when you press the button.

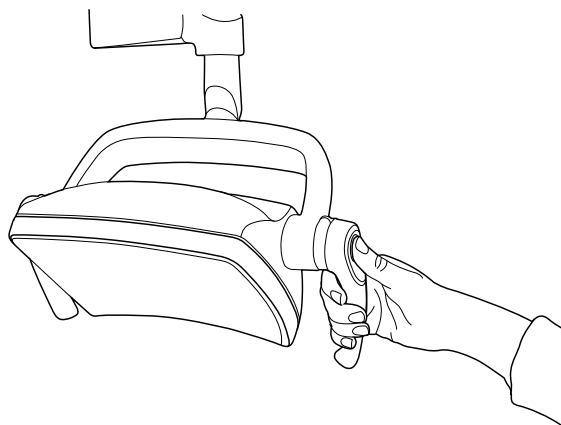

Hands-free with sensor

Wave your hand shortly in front of the sensor to switch on/off the operating light. The light will switch on/off **after** you have moved your hand away from the sensor activation area.

You will hear a clicking sound when you wave your hand in front of the sensor.

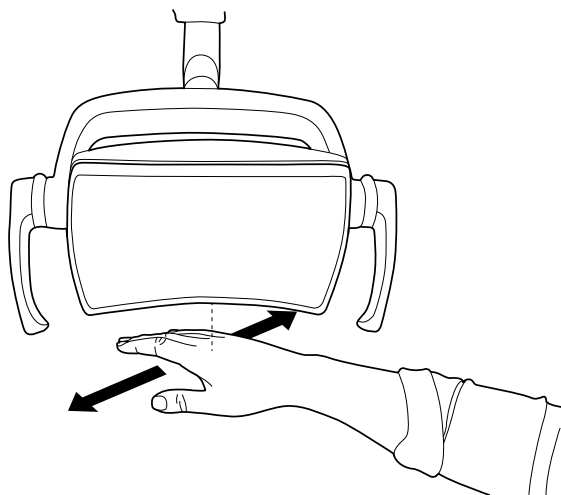

From dental unit

When you switch the operating light on, the indicator light on the **Operating light** button is lit.

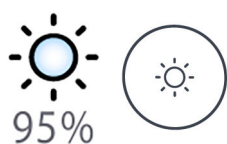

Control panel: Press **Operating light** to switch the operating light on or off.

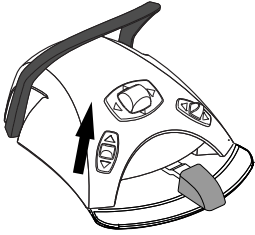

Foot control: Push the left-side knob up to switch the operating light on/off. This is the default factory setting.

NOTE

The foot control can also be configured so that the operating light is switched on/off when you push the right-side knob up. Contact your Planmeca dealer.

22.6.3 Switching composite mode on/off

The composite mode allows you to work with composite materials with minimal risk of pre-polymerisation caused by the operating light.

The composite mode turns off automatically when another instrument than the polymerisation light is picked up from the instrument console.

From operating light

From one handle

Press twice the handle button on either handle to switch to composite mode. Press the handle button twice again to switch the composite mode off.

You will hear a clicking sound each time you press the button.

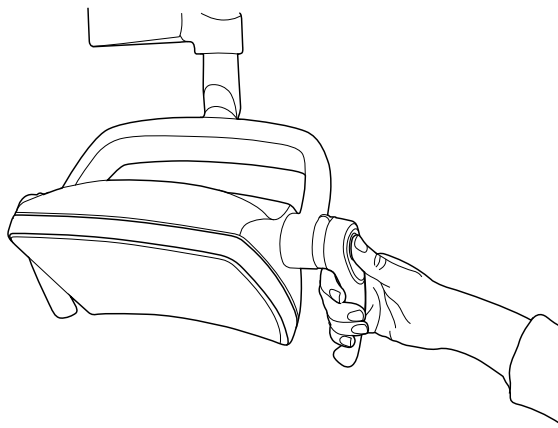

Hands-free with sensor

Wave your hand twice in front of the sensor to switch the composite mode on/off.

The light will switch to composite mode after you have moved your hand away from the sensor activation area for the second time.

You will hear a clicking sound each time you wave your hand in front of the sensor.

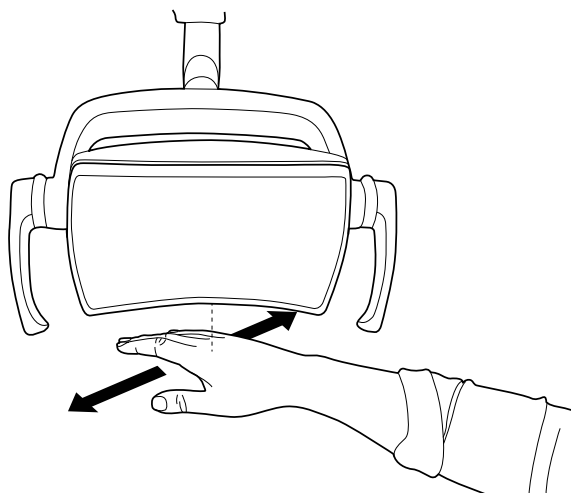
**From dental unit**

When you switch the composite mode on, the indicator light on the **Composite mode** button is lit.



35%

Control panel: Press **Composite mode** to switch the operating light's composite mode on or off.

**NOTE**

The dental unit can be configured so that you can switch the operating light's composite mode on or off by pressing the Flexy button. Contact your Planmeca dealer.

NOTE

The foot control can be configured so that the composite mode is switched on/off when you push the left- or the right-side knob up. Contact your Planmeca dealer.

**NOTE**

When the polymerisation light is taken from the holder and returned to it, the composite mode is switched on. This feature is configurable; contact your Planmeca dealer.

22.6.4 Adjusting intensity of operating light

The intensity adjustment range is from 30% to 100%.

Each time you adjust the intensity, the direction of the adjustment (increase/decrease) changes. Thus, if you first increase the intensity, the intensity will be decreased the next time you adjust it.

You will hear short successive clicking sounds while the intensity is being adjusted and a long signal tone when the maximum/minimum intensity is reached.

The operating light intensity can also be programmed, see section "Planmeca Solanna and Planmeca Solanna Vision operating lights" on page 194.

NOTE

The operating light intensity will decrease to 30% of the maximum intensity when the chair is moving.

From operating light

From one handle

Press and hold the handle button on either handle to adjust the intensity of the operating light. The intensity increases/decreases for as long as you press the button.

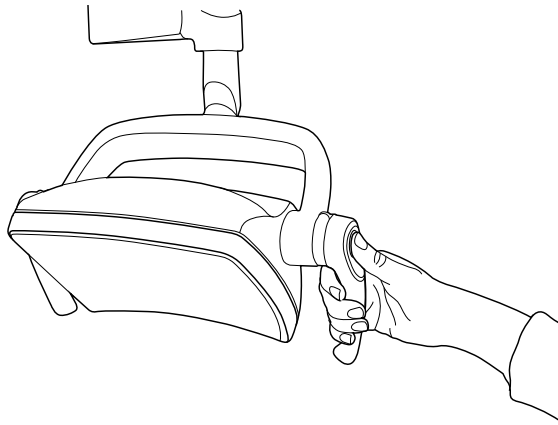

Hands-free with sensor

Once the operation light is lit, keep your hand longer in front of the sensor to adjust the intensity of the light.

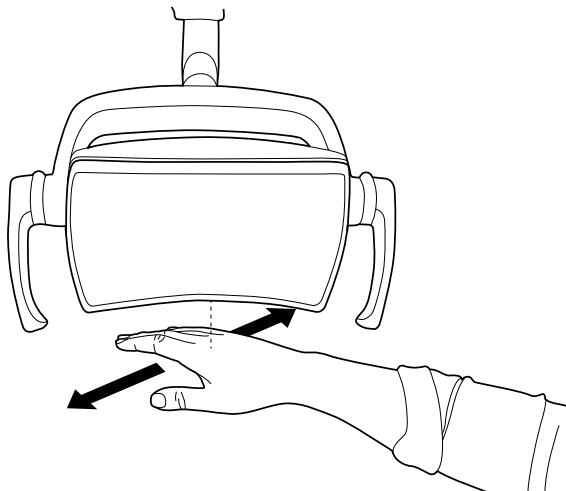

NOTE

If the operating light is installed to another manufacturer's dental unit, the intensity adjustment can be done only from the operating light.

From dental unit

The light intensity is displayed on the **Operating light** button. When you change the intensity, the information on the button changes accordingly.

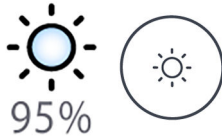

Control panel: Press and hold the **Operating light** button to adjust the operating light intensity.

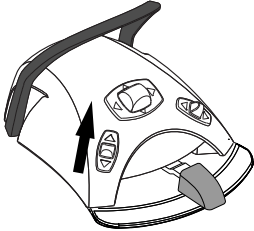

Foot control: Push and hold the left-side knob up to adjust the operating light intensity.

NOTE

The foot control can also be configured so that the intensity is adjusted when you push and hold the right-side knob up. Contact your Planmeca dealer.

After one second, the intensity will increase until you release the button/knob. When you press and hold the button/knob again, the intensity will start to decrease.

22.6.5 Adjusting intensity of operating light in composite mode

The intensity adjustment range is from 30% to 100%.

Each time you adjust the intensity, the direction of the adjustment (increase/decrease) changes. Thus, if you first increase the intensity, the intensity will be decreased the next time you adjust it.

You will hear short successive clicking sounds while the intensity is being adjusted and a long signal tone when the maximum/minimum intensity is reached.

The operating light intensity can also be programmed, see section "Planmeca Solanna and Planmeca Solanna Vision operating lights" on page 194.

From operating light

From one handle

Press and hold the handle button on either handle to adjust the intensity of the operating light. The intensity increases/decreases for as long as you press the button.

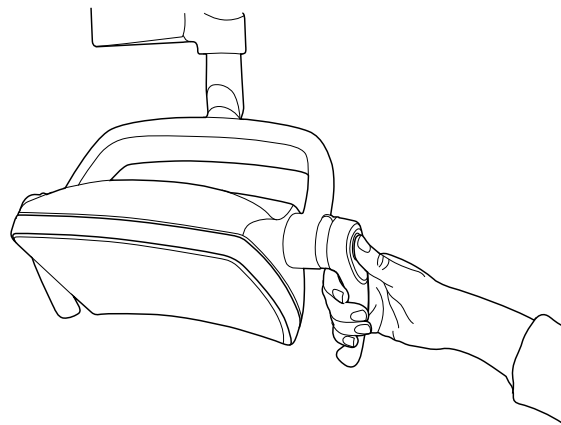

Hands-free with sensor

Once the operation light is lit, keep your hand longer in front of the sensor to adjust the intensity of the light.

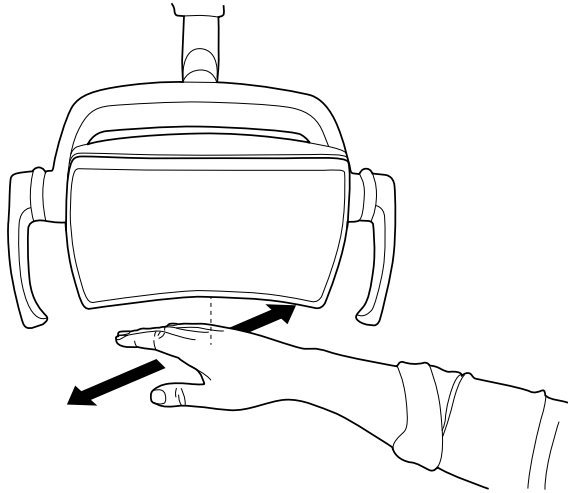
**NOTE**

If the operating light is installed to another manufacturer's dental unit, the intensity adjustment can be done only from the operating light.

From dental unit

The light intensity of the composite mode is displayed on the **Composite mode** button. When you change the intensity, the information on the button changes accordingly.



35%

Control panel: Press and hold the **Composite mode** button to adjust the light intensity of the composite mode.

NOTE

The dental unit can be configured so that the operating light's intensity in the composite mode can be adjusted when you press and hold the **Flexy** button. Contact your Planmeca dealer.

**NOTE**

The foot control can be configured so that the intensity is adjusted when you push and hold the left-side or the right-side knob up. Contact your Planmeca dealer.

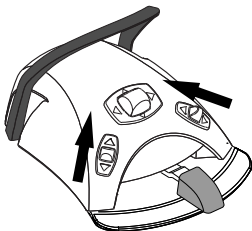
**22.6.6 Changing light tone of operating light**

The white light tone of the operating light can be warm, neutral or cool.

From operating light

From both handles

When the light is on (and composite mode off), press and hold both handle buttons simultaneously to toggle between the three colour temperatures warm, neutral and cool.

You will hear a signal tone when you toggle the colour temperature from the handle buttons.

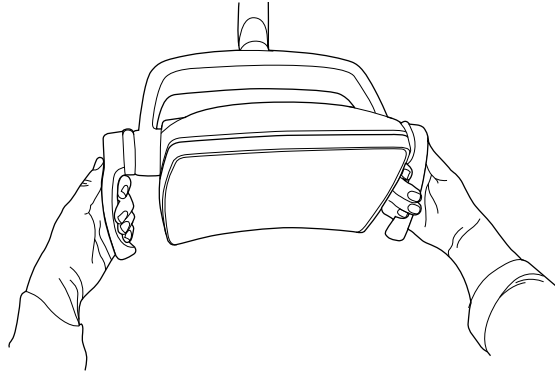

From dental unit

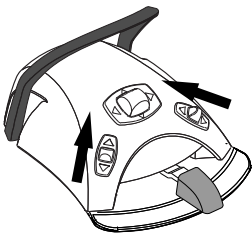

You can change the light tone by pushing the left-side or the right-side knob up, if this function has been configured to the foot control. To configure the function, contact your Planmeca dealer.



Alternatively, you can change the light tone by pressing the **Flexy** button, if this function has been configured to the **Flexy** button. To configure the function, contact your Planmeca dealer.

You can also change the light tone in the programming window, see section "Colour temperature and brightness" on page 195.

22.7 Planmeca Solanna Vision camera

Prerequisites







- Planmeca Romexis software version 6.0 or later must be installed. When Planmeca Romexis is running, the camera is continuously connected to the software.
- Planmeca Romexis and the dental unit have been paired by a Planmeca service technician.
- The connection between Planmeca Romexis and the dental unit has been enabled by a Planmeca service technician.

Solanna Vision button

The **Solanna Vision** button on the control panel features indicators for video streaming and recording, as well as an indicator light for each camera to mark the status of the camera.

NOTE

The left/right notation is as seen from behind the camera.

Button example	Status
	Right camera not selected; no connection between the camera and the control panel. Left camera selected but not activated.
	Right camera not selected; no connection between the camera and the control panel. Left camera selected, video streaming is on, no video is being recorded.
	Right camera not selected; no connection between the camera and the control panel. Left camera selected, video is being recorded. Recording time runs below button until recording is stopped.
	Planmeca Romexis has not identified the camera or the Planmeca Romexis client paired with the dental unit has been switched off.
	Solanna Vision software update is being loaded. Note that the blinking <i>i</i> icon can also appear independently from the Solanna Vision button.
	Solanna Vision software has been loaded. Restart the dental unit to update the software. Note that the <i>software downloaded</i> icon can also appear independently from the Solanna Vision button.

After you have saved videos and images

The images and videos are automatically saved to the selected patient file in Planmeca Romexis software. The images can be viewed in the 2D module window and the videos as attachments in the *Patient data* window.

For more information on how to open these windows, see *Planmeca Romexis user's manual*.

To be able to view a recorded video, a separate video software, such as Windows Media Player, QuickTime Player or VLC Media Player must be installed on the computer and configured to open files with the .mp4 file extension. The videos can be edited in any 3rd party video editing program.

22.7.1 Starting to use cameras

22.7.1.1 Activating camera from Planmeca Romexis

Steps

1. Select a patient to open the patient file.
2. Select the 2D module.
3. To activate the camera, click the **Solanna Vision** button.



NOTE

Alternatively, you can click the *Solanna Vision* button in the *File* module.



Video streaming starts and the live stream can be viewed in the *Solanna Vision* window in Planmeca Romexis. On the dental unit touch screen, a blue streaming icon at the top of the window indicates that video streaming is on. When the icon is grey, no streaming is going on.

NOTE

This does not open the *Solanna Vision* window in the dental unit.

TIP

To switch full screen mode on/off, press the **f** key on the Planmeca Romexis keyboard.

To switch low latency mode on/off, press the **l** key on the Planmeca Romexis keyboard

22.7.1.2 Activating camera from dental unit

Before activating the Planmeca Solanna Vision camera from the dental unit you must do the following in Planmeca Romexis:

1. Select a patient to open the patient file.
2. Select the *2D* module.

To activate the camera, open the *Solanna Vision* window on the dental unit. When the window opens, video streaming automatically starts.

NOTE

When the *Solanna Vision* window is open on the dental unit, the indicator lights on the operating light handles are blue and the operating light can not be operated from the handle buttons. You can, however, use the operating light hands-free with the gesture sensor, if the sensor is enabled.



How to open Solanna Vision window on dental unit

Interface	Action
Planmeca dental unit: Control panel on instrument console	 Press Solanna Vision in the main window to open the <i>Solanna Vision</i> window.
Planmeca dental unit: Control panel on Flexy holder	Planmeca Compact i: The <i>Solanna Vision</i> window can be configured to be opened by pressing the Flexy button, contact your Planmeca dealer.
Planmeca dental unit: Foot control	Planmeca Compact i: The <i>Solanna Vision</i> window can be configured to be opened from one of the side knobs on the foot control, contact your Planmeca dealer.

The *Solanna Vision* window gives you access to the Solanna Vision controls.

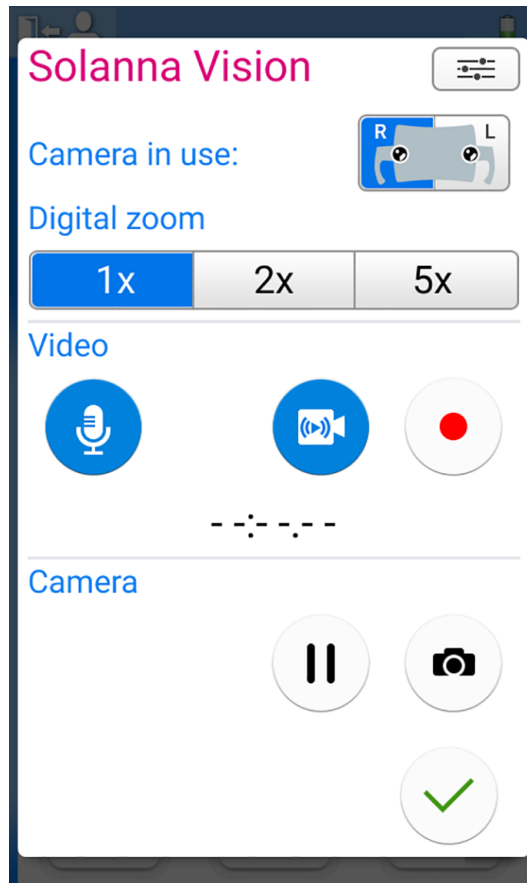

When the *Solanna Vision* dental unit window is not open, the operating light, instruments, dental unit and chair can be used normally, also when streaming or recording is running in the background.



Press **OK** to close the *Solanna Vision* dental unit window.

22.7.2 Adjusting camera settings from dental unit

22.7.2.1 Selecting camera and zoom level

About this task

Planmeca Solanna Vision has two cameras. Select which camera you want to use.



NOTE

It is possible to select the camera also from the Planmeca Romexis keyboard by pressing keyboard buttons 1, 2 or 3.

- 1 = When Planmeca Solanna Vision is connected to a Planmeca dental unit, the camera that has been selected in the dental unit's control panel is used.
- 2 = The right camera (as seen from behind the camera) is selected.
- 3 = The left camera (as seen from behind the camera) is selected.

Steps

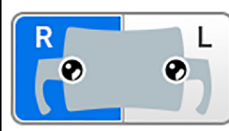
1. Open the *Solanna Vision* window in the dental unit.
For instructions, see section "Activating camera from dental unit" on page 118.
2. Select the camera by pressing the corresponding camera button.

	Right camera (as seen from behind the camera) selected. Press to unselect.
	Left camera (as seen from behind the camera) selected. Press to unselect.

3. Select the level of digital zoom by pressing the corresponding button.
The options are 1x, 2x and 5x zoom. The selected option is indicated by a blue button.

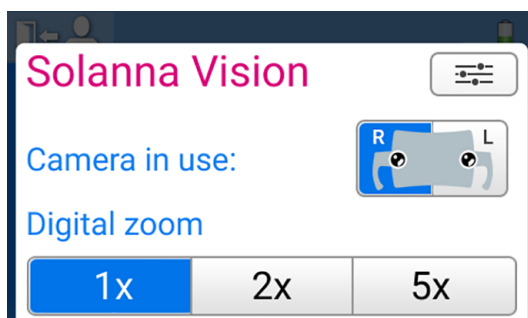

22.7.2.2 Adjusting video settings

Steps

1. Open the *Solanna Vision* window in the dental unit.
For instructions, see section "Activating camera from dental unit" on page 118.
2. In the *Solanna Vision* window, press **Settings**.



The *Video settings* programming window opens.

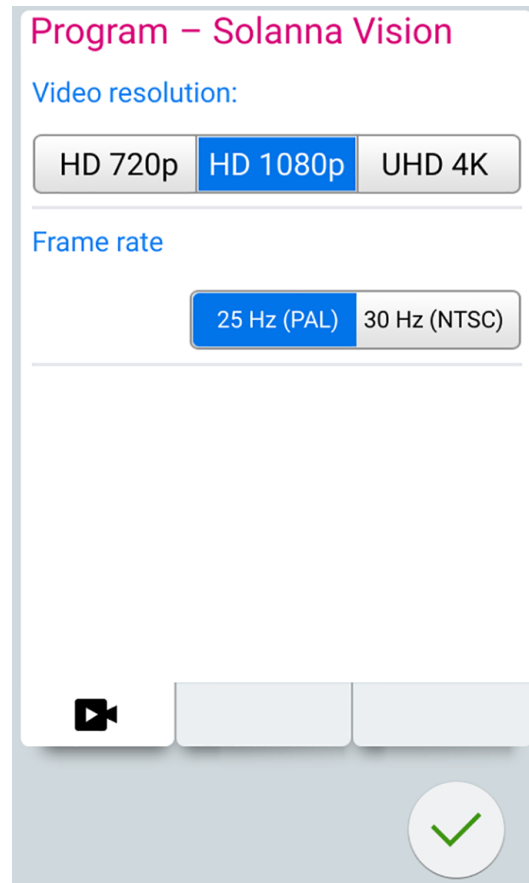

3. Select the video resolution by pressing on the preferred resolution.

The options are:

- HD 720p (1280x720)
- Full HD 1080p (1920x1080)
- UHD 4K (3840x2160)

A blue background indicates the selected resolution.

The selected resolution affects the video clip file size. The approximate file sizes are listed below.

Approximate video sizes	HD 720p	HD 1080p	UHD 4K
1 min	30 MB	60 MB	240 MB
15 min	450 MB	900 MB	3.6 GB
1 hour	1.8 GB	3.6 GB	14.4 GB

4. Select the frame rate by pressing on the preferred frame rate.

The options are 25 Hz (PAL) and 30 Hz (NTSC).

A blue background indicates the selected frame rate.

5. Press **OK**.



22.7.3 Switching video streaming on/off

When video streaming is on, the live video stream is played in the *Solanna Vision* window in Planmeca Romexis.

When you turn streaming off, the *Solanna Vision* window in Planmeca Romexis closes. The window opens again when you turn streaming on.

Pausing streaming does not close the *Solanna Vision* window in Planmeca Romexis, it just freezes the picture.











NOTE

If streaming does not start when you switch video streaming on, check if you have selected a camera. For instructions, see section "Adjusting camera settings from dental unit" on page 119.

NOTE

In the *Solanna Vision* window, both in the dental unit and Planmeca Romexis, a blue button means that the function is on, and a grey button that the function is off.

How to switch video streaming on/off

Interface	Action
Planmeca dental unit: Control panel on instrument console	  In the <i>Solanna Vision</i> window, press Video camera to turn video streaming on/off.
	  In the <i>Solanna Vision</i> window, press Pause to pause video streaming. Press Pause again to resume streaming.
	  In the <i>Solanna Vision</i> window, press Microphone to mute/unmute the microphone.
Planmeca dental unit: Control panel on Flexy holder	Planmeca Compact i: Video streaming can be configured to be switched on/off from the Flexy button, contact your Planmeca dealer.
Planmeca dental unit: Foot control	Planmeca Compact i: Video streaming can be configured to be switched on/off from one of the side knobs on the foot control, contact your Planmeca dealer.
Planmeca Romexis	  In the <i>Solanna Vision</i> window, click Streaming to turn video streaming on/off.
	  In the <i>Solanna Vision</i> window, press Pause to pause video streaming. Press Pause again to resume streaming.
	<input type="checkbox"/> Sound In the <i>Solanna Vision</i> window, check the Sound checkbox to turn on the microphone.
	When the <i>Solanna Vision</i> window is open, press the Space key on the Planmeca Romexis keyboard to pause streaming. Press Space again to resume streaming.



Planmeca dental unit: When video streaming is on, the camera indicator light on the *Solanna Vision* button in the main window indicates that streaming is going on.



Planmeca Romexis: When video streaming is on, a green streaming icon in the top right corner of the *2D* module and *File* module window indicates that streaming is going on.

Streaming to multiple clients

NOTE

This feature requires Planmeca Romexis software version 6.3 or later.

It is possible to stream live video from Planmeca Solanna Vision to multiple clients, including 3rd party applications, such as Open Broadcaster Software (OBS) Studio. To enable streaming to multiple clients, contact your local Planmeca dealer.

22.7.4 Recording video







You can record a video only when video streaming is on.

By default, the length of the video is unlimited. To limit the length, contact your Planmeca dealer.

NOTE

In the *Solanna Vision* window, both in the dental unit and Planmeca Romexis, a blue button means that the function is on, and a grey button that the function is off.

How to record video

Interface	Action
Planmeca dental unit: Control panel on instrument console	  In the <i>Solanna Vision</i> window, press Record to start/stop recording.
	  In the <i>Solanna Vision</i> window, press Microphone to turn the microphone on/off.
Planmeca dental unit: Control panel on Flexy holder	Planmeca Compact i: Recording can be configured to be started/stopped from the Flexy button, contact your Planmeca dealer.
Planmeca dental unit: Foot control	Planmeca Compact i: Recording can be configured to be started/stopped from one of the side knobs on the foot control, contact your Planmeca dealer.
Planmeca Solanna Vision	When the <i>Solanna Vision</i> window is open on the dental unit's control panel, press the handle button for >0.5 seconds to start/stop recording. A signal tone indicates the start of recording. The indicator light on the handle button blinks blue - light blue while recording is going on.
Planmeca Romexis	  In the <i>Solanna Vision</i> window, click Video camera to start/stop recording.
	When the <i>Solanna Vision</i> window is open, press the r key on the Planmeca Romexis keyboard to start/stop recording.



Planmeca dental unit: When recording is going on, the camera indicator light on the **Solanna Vision** button in the main window blinks to indicate that recording is going on.



Planmeca Romexis: When recording is going on, a red recording icon in the top left corner of the *Solanna Vision* window indicates that recording is going on.

Also, in the *2D* module and *File* module windows, a red video camera icon in the top right corner indicates that recording is going on.

22.7.5 Capturing image

You can capture an image only when video streaming is on.

How to capture image

Interface	Action
Planmeca dental unit: Control panel on instrument console	 In the <i>Solanna Vision</i> window, capture an image by pressing Still camera .
Planmeca dental unit: Control panel on Flexy holder	Planmeca Compact i: The dental unit can be configured so that an image is captured when you press the Flexy button, contact your Planmeca dealer.
Planmeca dental unit: Foot control	Planmeca Compact i: The dental unit can be configured so that an image is captured when you push one of the side knobs on the foot control, contact your Planmeca dealer.
Planmeca Solanna Vision	When the <i>Solanna Vision</i> window is open on the dental unit's control panel, press the handle button to capture an image. You will hear a clicking sound when you press the button.
Planmeca Romexis	 In the <i>Solanna Vision</i> window, capture an image by clicking Still camera .
	When the <i>Solanna Vision</i> window is open, press the Enter or p key on the Planmeca Romexis keyboard to capture an image.

22.8 X-ray film viewer



The control panel display can be used for viewing X-ray films. To open the viewer, press **X-ray film viewer**.

When the display is used as an X-ray film viewer, its intensity is increased to the maximum value.

CAUTION

The X-ray film viewer is suited for X-ray films with an optical density of ≤ 1.2 OD. It is not a tool for diagnosis.



When you want to close the X-ray film viewer, press **OK**.

23 Operating instruments

23.1 Instrument logic

NOTE

If you use similar instruments at the same time, keep them in their own places. The memory operation does not recognise the parameters and settings of the similar instruments if their places are changed.

The dental unit contains an instrument logic with the principles described below. The active instrument can be operated with the foot control and its settings are displayed on the control panel and they can be changed.

When the active instrument is operated, other instruments can be away from the instrument console, but they can not be operated.

The syringe can be operated independently of other instruments at any time.

1. When the dentist picks up instrument 1 from the instrument console, it becomes the active instrument. The dentist can drive it with the foot control pedal (a short push to the right/left or down is enough).
2. While the dentist drives instrument 1, the assistant can pick up instrument 2 for preparation. Picking up instrument 2 does not change the active instrument.
3. The dentist returns the active instrument (instrument 1) to the instrument console.
4. The assistant returns instrument 2 to the instrument console.
5. The dentist activates instrument 2 by picking it up from the instrument console. After this, it can be driven with the foot control as above.

The memory operation of the logic settings makes it possible to store parameters and settings for up to eight instruments. Changing the place of the instrument on the console does not change the parameters and settings of that instrument.

Intelligent four-handed dentistry

In four-handed dentistry it is important to enable a smooth preparation and exchange of instruments between the dentist and the assistant. Therefore, an alternative instrument logic can be taken into use for four-handed dentistry. Please contact your Planmeca dealer.

In intelligent four-handed dentistry one instrument can be left waiting in a queue so that it is ready for use when the dentist returns the active instrument to the instrument console.

The intelligent four-handed dentistry follows the principles described below. The active instrument can be operated with the foot control and its settings are displayed on the control panel and they can be changed.

The instrument logic does not control the syringe which can be used at any time.

1. When the dentist picks up instrument 1 from the instrument console, it becomes the active instrument. The dentist can drive it with the foot control pedal (a short push to the right/left or down is enough).
2. While the dentist drives instrument 1, the assistant can pick up instrument 2 for preparation and the instrument goes to the instrument queue.

NOTE

Only one instrument at a time can be in the queue. If two or three instruments are picked up while driving an instrument, only the instrument that was picked up last will remain in the queue.

- The dentist returns the active instrument (instrument 1) to the instrument console and immediately the instrument in the queue (instrument 2) is activated and handed to the dentist by the assistant. Instrument 2 can be driven with the foot control as described above.

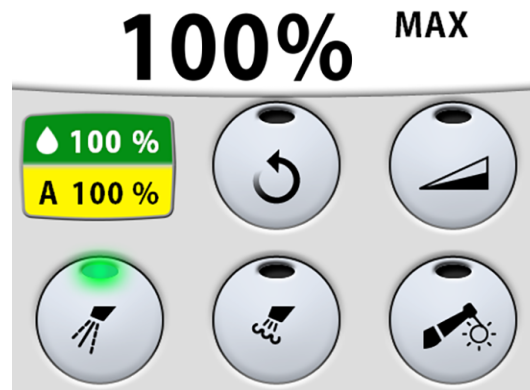
23.2 Micromotor**23.2.1 Speed/power**

Standard pedal: To drive the instrument, push the foot control pedal to the right or to the left.

Wide pedal: To drive the instrument, push the foot control pedal down.

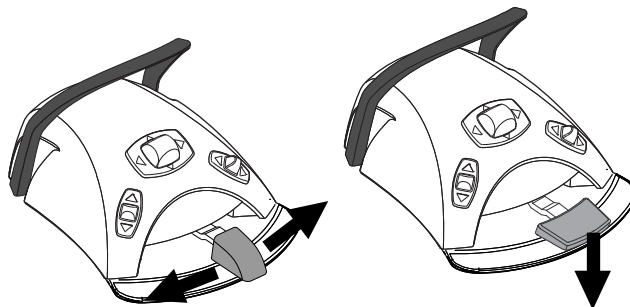

Pushing the pedal further to the right/left or down will increase the speed or power of the instrument. As you push the pedal, the power output is displayed on the control panel.

The normal range is 10 - 100%.

To stop the instrument, allow the pedal to return to the rest position.

CAUTION

Ensure that the pedal is in rest position when you activate the instrument.

NOTE

The speed/power level depends on the instrument.

23.2.2 Reverse rotation



In normal operation the micromotor rotates in a clockwise direction. To reverse the direction of rotation press **Reverse**. Reversing is possible only when the micromotor is picked up from the instrument console, but not operated.

When the micromotor rotates in the reverse direction, the indicator light is amber. To enable a low ticking sound during reverse rotation, please contact your Planmeca dealer.

NOTE

The foot control can be configured so that the reverse rotation is activated/deactivated when you push the left-side knob down. Contact your Planmeca dealer.

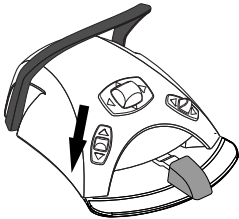

NOTE

Check the indicator light on the control panel to verify that pushing the left-side knob down activates the correct function.

23.2.3 Speed/power limit

When the micromotor's speed/power limit is on and set to, for example, 50%, the foot control pedal movement controls the speed/power between 10 - 50% instead of the normal range of 10 - 100%. The preset maximum value is displayed on the control panel when the micromotor is picked up from the instrument console.

When the speed/power limit is on, the indicator light on the control panel button is green.



Control panel: Press **Micromotor speed/power limit** to reduce the micromotor's speed or power to a preset level. Press **Micromotor speed/power limit** again to switch the power limit off.

NOTE

The foot control can be configured so that the micromotor's speed or power is limited when you push the left-side knob down. Contact your Planmeca dealer.



NOTE

Check the indicator light on the control panel to verify that pushing the left-side knob down activates the correct function.

NOTE

The speed/power limit can be programmed. See section "Instrument speed/power limit" on page 178.

NOTE

Note that the speed/power limit depends on the instrument.

23.2.4 Instrument spray

The instrument cooling spray setting can be selected to be water & air, air or no spray.

The spray flow rate can be programmed. See section "Instrument spray" on page 178.



The amounts of water and air for the currently used spray type are displayed on the control panel.



When sterile water is used, you can select between sterile water spray and spray off. Sterile water is indicated by a Sterile water symbol and the indicator light blinks green on the **Instrument spray** button.

For instructions on how to enable/disable the sterile mode, see section "Enabling/disabling sterile water mode" on page 179.



Press **Instrument spray** once to switch on the water & air spray. You will hear two short signal tones. Additionally, a green indicator light shows that the water & air spray is switched on.



Press **Instrument spray** a second time to switch the air spray on. You will hear one short signal tone. Additionally, a yellow indicator light shows that the air spray is switched on.



Press **Instrument spray** a third time to switch off the instrument cooling spray. You will hear one long signal tone. Additionally, the indicator light goes out.

Alternatively, you can select the spray setting with the foot control. The indicator lights on the control panel are lit accordingly.

Standard pedal: Push the pedal down briefly to select the spray setting.

Wide pedal: Push the pedal briefly to the left to select the spray setting.

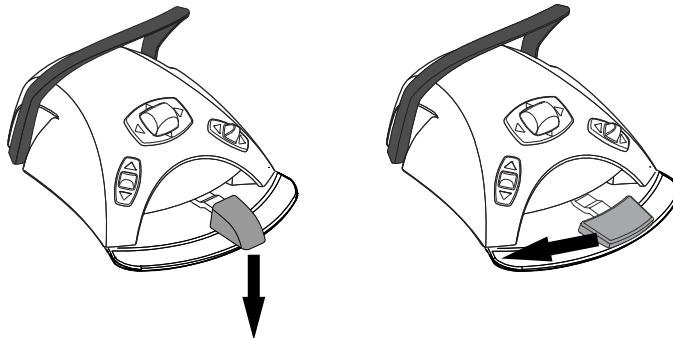

Push the pedal once to switch on the water & air spray. You will hear two short signal tones.

Push the pedal again to switch on the air spray. You will hear one short signal tone.

Push the pedal a third time to switch off the instrument spray. You will hear one long signal tone.

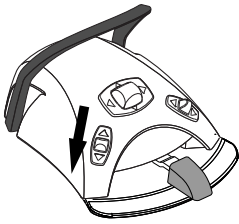
**NOTE**

The foot control can also be configured so that you push the left-side knob down to select a different spray setting. Contact your Planmeca dealer.

NOTE

Check the indicator light on the control panel to verify that pushing the left-side knob down activates the correct function.

NOTE

The spray must be switched off when using an instrument without a waterline inside the handpiece.

NOTE

The instrument spray operated with the foot control can be disabled in the service mode, in which case you can switch the spray on and off only from the control panel. Contact your Planmeca dealer.

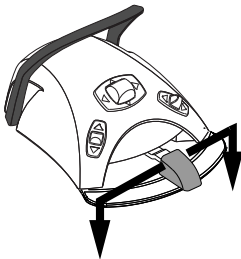
23.2.5 Momentary spray

When you are driving the instrument, you can activate the momentary spray by pressing the foot control pedal down. The spray will continue until you remove your foot from the pedal.

NOTE

The momentary spray can be enabled and configured in the service mode, contact your Planmeca dealer.

NOTE

The momentary spray can not be activated with the wide foot control pedal.

23.2.6 Automatic chip blow

When the automatic chip blow is on, the indicator light on the control panel button is on and two short blows of water, air, or both will occur after the instrument is stopped.



Control panel: Press **Chip blow** to switch the automatic chip blow on or off.

NOTE

The foot control can be configured so that you push the left-side knob down to switch the automatic chip blow on/off. Contact your Planmeca dealer.

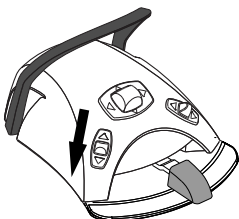
**NOTE**

Check the indicator light on the control panel to verify that pushing the left-side knob down activates the correct function.

The type of chip blow can be programmed, see section "Automatic chip blow" on page 180.

23.2.7 Manual chip blow

Standard pedal: You can temporarily activate the manual chip blow by pushing and holding down the pedal.

Wide pedal: You can temporarily activate the manual chip blow by pushing and holding the pedal to the right.

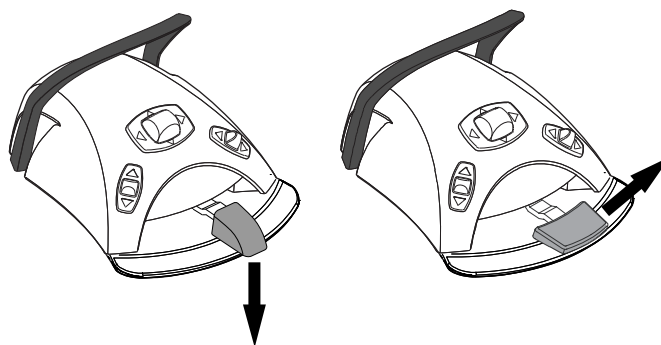

The flow of air will continue until you remove your foot from the pedal.

NOTE

The type of manual chip blow does not depend on the type of the automatic chip blow, but is always dry. The manual chip blow can be set to be dependent on programming; contact your Planmeca dealer.

23.2.8 Instrument light

When the instrument light is on, the indicator light on the control panel button is green.



Control panel: Press **Instrument light** to switch the instrument light on/off.

NOTE

The foot control can be configured so that you push the left-side knob down to switch the instrument light on/off. Contact your Planmeca dealer.



NOTE

Check the indicator light on the control panel to verify that pushing the left-side knob down activates the correct function.

The instrument light intensity can be programmed, see section "Instrument light" on page 180.

23.3 Bien-Air MCX and KaVo KL703 LED micromotors



In addition to the functions described in section "Micromotor" on page 126, the Bien-Air MCX and KaVo KL703 LED micromotors have some additional features. These are described below.

23.3.1 Torque



Press **Torque** to enable the torque function. The green indicator light means that torque is enabled.

When torque is enabled, the motor torque is limited to the programmed setting.

NOTE

The foot control can be configured so that you push the left-side knob down to enable/disable the torque function. Contact your Planmeca dealer.



NOTE

Check the indicator light on the control panel to verify that pushing the left-side knob down activates the correct function.

The following table presents a conversion table of percentage values to Ncm values for a 1:1 handpiece.

NOTE

The torque values are approximate and depend on the handpiece type.

Conversion table: % to Ncm (1:1 handpiece)

Percent	Ncm	
	Bien-Air MCX	KaVo KL703 LED
10	0.3	0.3
15	0.4	0.5
20	0.5	0.6
25	0.6	0.8

Conversion table: % to Ncm (1:1 handpiece)

Percent	Ncm	
	Bien-Air MCX	KaVo KL703 LED
30	0.8	0.9
35	0.9	1.1
40	1.0	1.2
45	1.1	1.4
50	1.3	1.5
55	1.4	1.7
60	1.5	1.8
65	1.6	2.0
70	1.8	2.1
75	1.9	2.2
80	2.0	2.4
85	2.1	2.6
90	2.3	2.7
95	2.4	2.9
100	2.5	3.0

23.3.2 RPM



Press **RPM limit** to reduce the micromotor’s maximum speed to a preset level. The green indicator light means that the RPM limit is on. Press **RPM limit** again to switch the rpm limit off.

23.4 Bien-Air MX2 Plus and KaVo KL703 LED with endo micromotors



In addition to the functions described in section "Micromotor" on page 126, the Bien-Air MX2 Plus and KaVo KL703 LED with endo micromotors have some additional features. These are described below.

CAUTION

Before using the torque and RPM functions, please refer to the file manufacturer's instructions concerning torque and RPM value recommendations for the files.

23.4.1 Torque

Press **Torque** to enable the torque function and access the drive modes. The green indicator light means that torque is enabled.

When torque is enabled, you can select the drive mode by pressing **Drive mode**, which always shows the current drive mode. The modes are:

**Torque control (Auto stop)**

The torque is limited to the set threshold. Once the limit is reached, the rotation stops, while the torque is maintained. Once some load is taken off the motor, the rotation continues.

**Auto reverse**

When the torque limit is reached the micromotor will operate counter-clockwise.

**Auto forward**

When the torque limit is reached, the micromotor will operate counter-clockwise (auto reverse) for 2 seconds and then return to clockwise direction.

(The length of the counter-clockwise rotation can be modified, see section "Modifying preset values" on page 183.)

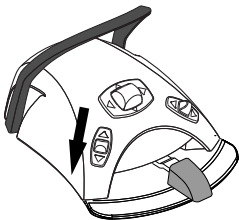
NOTE

The foot control can be configured so that you push the left-side knob down either to enable/disable the torque function or to select the drive mode. Contact your Planmeca dealer.

NOTE

Check the indicator light and the drive mode symbol on the control panel to verify that pushing the left-side knob down activates the correct function.

NOTE

Reverse rotation can not be enabled in the Auto reverse and Auto forward modes.

NOTE

Torque can be disabled only in the Auto stop / Torque control mode.

The following table presents a conversion table of percentage values to Ncm values for a 1:1 handpiece. The tolerance is +/- 5%.

NOTE

The torque depends on the handpiece type.

Conversion table: % to Ncm

Percent	Ncm	
	Bien-Air MX2 Plus	KaVo KL703 LED with endo
10	0.4	0.3
15	0.5	0.5
20	0.7	0.6
25	0.9	0.8
30	1.1	0.9
35	1.2	1.1
40	1.4	1.2
45	1.6	1.4
50	1.8	1.5
55	1.9	1.7
60	2.1	1.8
65	2.3	2.0
70	2.5	2.1
75	2.6	2.2
80	2.8	2.4
85	3.0	2.6
90	3.2	2.7
95	3.3	2.9
100	3.5	3.0

23.4.2 RPM



Press **RPM limit** to reduce the micromotor's maximum speed to a preset level. The green indicator light means that the RPM limit is on. Press **RPM limit** again to switch the limit off.

23.4.3 Presets



Each user has a personal set of presets for the micromotor.

Six different presets are available and the **Preset** button displays the currently used preset.

The Bien-Air MX2 Plus micromotor has the presets 1–6. The KaVo KL703 LED with endo micromotor has the presets 1–3 and the endodontic presets e1–e3.

If you want to use another preset than the current, follow the steps below.

1. Activate the micromotor.
2. Press **Preset**.
3. In the window that opens, select the desired preset. You will then automatically be returned to the micromotor window.

The following tables present the default preset settings for the Bien-Air MX2 Plus and the KaVo KL703 LED with endo micromotors. These presets can be modified, see section "Modifying preset values" on page 183.

The tolerance for RPM and torque values is +/- 5%.

The following terms and abbreviations are used in the tables:

- Normal = No torque control
- ToCo = Torque Control
- AuRe = Auto Reverse
- AuFo = Auto Forward

Bien-Air MX2 Plus presets

Function	Preset 1 (default when instrument is selected first time)	Preset 2	Preset 3	Preset 4	Preset 5	Preset 6
Drive mode	Default: AuFo Adjusting: Normal, ToCo, AuFo, AuRe	Default: AuRe Adjusting: Normal, ToCo, AuFo, AuRe	Default: Normal Adjusting: Normal, ToCo, AuFo, AuRe	Default: Normal Adjusting: Normal, ToCo, AuFo, AuRe	Default: Normal Adjusting: Normal, ToCo, AuFo, AuRe	Default: Normal Adjusting: Normal, ToCo, AuFo, AuRe
RPM limit	Default: Off (260 when limited) Adjusting: On: 100-38000 / Off: 100- 40000	Default: On (260 when limited) Adjusting: On: 100-38000 / Off: 100- 40000	Default: On (900 when limited) Adjusting: On: 100-38000 / Off: 100- 40000	Default: On (2000 when limited) Adjusting: On: 100-38000 / Off: 100- 40000	Default: On (5000 when limited) Adjusting: On: 100-38000 / Off: 100- 40000	Default: Off (10000 when limited) Adjusting: On: 100-38000 / Off: 100- 40000
Torque %	Default: On (30% when limited) Adjusting: On: 10- 95% / Off: 100%	Default: On (30% when limited) Adjusting: On: 10- 95% / Off: 100%	Default: On (50% when limited) Adjusting: On: 10- 95% / Off: 100%	Default: Off (50% when limited) Adjusting: On: 10- 95% / Off: 100%	Default: Off (50% when limited) Adjusting: On: 10- 95% / Off: 100%	Default: Off (50% when limited) Adjusting: On: 10- 95% / Off: 100%
Instrument spray	Default: Off (Air: 70%, Water 40%) Adjusting: Sterile / off / on (Air 0- 100%, Water 0- 100%)	Default: Off (Air: 70%, Water 40%) Adjusting: Sterile / off / on (Air 0- 100%, Water 0- 100%)	Default: Off (Air: 70%, Water 40%) Adjusting: Sterile / off / on (Air 0- 100%, Water 0- 100%)	Default: On (Air: 70%, Water 40%) Adjusting: Sterile / off / on (Air 0- 100%, Water 0- 100%)	Default: On (Air: 70%, Water 40%) Adjusting: Sterile / off / on (Air 0- 100%, Water 0- 100%)	Default: On (Air: 70%, Water 40%) Adjusting: Sterile / off / on (Air 0- 100%, Water 0- 100%)

Bien-Air MX2 Plus presets

Function	Preset 1 (default when instrument is selected first time)	Preset 2	Preset 3	Preset 4	Preset 5	Preset 6
Automatic chip blow	Default: Off (Air: 100%, Water 0% when on) Adjusting: Off/on (Air 0–100%, Water 0– 100%)	Default: Off (Air: 100%, Water 0% when on) Adjusting: Off/on (Air 0–100%, Water 0– 100%)	Default: Off (Air: 100%, Water 0% when on) Adjusting: Off/on (Air 0–100%, Water 0– 100%)	Default: Off (Air: 100%, Water 0% when on) Adjusting: Off/on (Air 0–100%, Water 0– 100%)	Default: Off (Air: 100%, Water 0% when on) Adjusting: Off/on (Air 0–100%, Water 0– 100%)	Default: Off (Air: 100%, Water 0% when on) Adjusting: Off/on (Air 0–100%, Water 0– 100%)
Instrument light brightness	Default: On 100% Adjusting: Off, on (70– 100%)	Default: On 100% Adjusting: Off, on (70– 100%)	Default: On 100% Adjusting: Off, on (70– 100%)	Default: On 100% Adjusting: Off, on (70– 100%)	Default: On 100% Adjusting: Off, on (70– 100%)	Default: On 100% Adjusting: Off, on (70– 100%)
Reverse	Default: Off Adjusting: On/off available with Normal/ ToCo drive mode	Default: Off Adjusting: On/off available with Normal/ ToCo drive mode	Default: Off Adjusting: On/off available with Normal/ ToCo drive mode	Default: Off Adjusting: On/off available with Normal/ ToCo drive mode	Default: Off Adjusting: On/off available with Normal/ ToCo drive mode	Default: Off Adjusting: On/off available with Normal/ ToCo drive mode

KaVo KL703 LED with endo presets

Function	Preset 1 (default when instrument is selected first time)	Preset 2	Preset 3	Preset e1	Preset e2	Preset e3
Drive mode	Default: Normal Adjusting: Normal, ToCo AuFo, AuRe	Default: Normal Adjusting: Normal, ToCo AuFo, AuRe	Default: Normal Adjusting: Normal, ToCo AuFo, AuRe	Default: ToCo Adjusting: Normal, ToCo AuFo, AuRe	Default: AuFo Adjusting: Normal, ToCo AuFo, AuRe	Default: AuRe Adjusting: Normal, ToCo AuFo, AuRe
RPM limit	Default: Off (1000 when limited) Adjusting: On: 100–38000 / Off: 100– 40000	Default: On (5000) Adjusting: On: 100–38000 / Off: 100– 40000	Default: On (2000) Adjusting: On: 100–38000 / Off: 100– 40000	Default: On (900) Adjusting: On: 100–38000 / Off: 100– 40000	Default: (On (260; Always set on, when AuFo) Adjusting: On: 100–38000	Default: (On (260; Always set on, when AuRe) Adjusting: On: 100–38000

KaVo KL703 LED with endo presets

Function	Preset 1 (default when instrument is selected first time)	Preset 2	Preset 3	Preset e1	Preset e2	Preset e3
Torque %	Default: Off (30% when limited) Adjusting: On: 10– 95% / Off: 100%	Default: Off (50% when limited) Adjusting: On: 10– 95% / Off: 100%	Default: Off (50% when limited) Adjusting: On: 10– 95% / Off: 100%	Default: On (50%) Adjusting: On: 10– 95% / Off: 100%	Default: On (30% fixed On when AuFo) Adjusting: On: 10–95%	Default: On (30% fixed On when AuRe) Adjusting: On: 10–95%
Instrument spray	Default: On (Air: 70%, Water 40%) Adjusting: Sterile / off / on (Air 0– 100%, Water 0– 100%)	Default: On (Air: 70%, Water 40%) Adjusting: Sterile / off / on (Air 0– 100%, Water 0– 100%)	Default: On (Air: 70%, Water 40%) Adjusting: Sterile / off / on (Air 0– 100%, Water 0– 100%)	Only sterile water available! Default: Off Adjusting: On/off	Only sterile water available! Default: Off Adjusting: On/off	Only sterile water available! Default: Off Adjusting: On/off
Automatic chip blow	Default: Off (Air: 100%, Water 0% when on) Adjusting: Off/on (Air 0–100%, Water 0– 100%)	Default: Off (Air: 100%, Water 0% when on) Adjusting: Off/on (Air 0–100%, Water 0– 100%)	Default: Off (Air: 100%, Water 0% when on) Adjusting: Off/on (Air 0–100%, Water 0– 100%)	Default: Off	Default: Off	Default: Off
Instrument light brightness	Default: On 100% Adjusting: Off, on (70– 100%)	Default: On 100% Adjusting: Off, on (70– 100%)	Default: On 100% Adjusting: Off, on (70– 100%)	Default: On 100% Adjusting: Off, on (70– 100%)	Default: On 100% Adjusting: Off, on (70– 100%)	Default: On 100% Adjusting: Off, on (70– 100%)
Reverse	Default: Off Adjusting: On/off available with Normal/ ToCo drive mode	Default: Off Adjusting: On/off available with Normal/ ToCo drive mode	Default: Off Adjusting: On/off available with Normal/ ToCo drive mode	Default: Off Adjusting: On/off available with Normal/ ToCo drive mode	Default: Off Adjusting: On/off available with Normal/ ToCo drive mode	Default: Off Adjusting: On/off available with Normal/ ToCo drive mode

23.5 Bien-Air MX-i micromotor



CAUTION

The user must be familiar with implant procedures before using the Bien-Air MX-i micromotor.

CAUTION

Always check the preset settings before using the micromotor.

The Bien-Air MX-i implantology micromotor is designed for implant insertion procedures with a 20:1 handpiece. Implant procedures should only be performed with the following handpieces:

- Contra-angle handpiece CA 20:1 L KM Micro-Series (light)1600786-001
- Contra-angle handpiece CA 20:1 L KM (light)1600785-001
- Contra-angle handpiece CA 20:1 L Micro-Series (light)1600692-001
- Contra-angle handpiece CA 20:1 L (light)1600598-001

Of the basic micromotor functions the Bien-Air MX-i micromotor does not have instrument cooling spray or chip blow. If the dental unit is equipped with a sterile water system, sterile water can be used.

The additional micromotor functions are described below.

23.5.1 Sterile water

If the dental unit is equipped with a sterile water system, sterile water spray can be used when presets i1 - i4 are selected.

NOTE

Sterile water is not available for preset i5.



When sterile water is available, the **Instrument spray** button is enabled.

Press **Instrument spray** to turn sterile water spray on/off. A green indicator light on the button shows that the sterile water spray is switched on.



The Sterile water symbol also indicates that the sterile water spray is switched on.

23.5.2 Torque

Presets i1 - i3 have a fixed torque value of 50 Ncm that can not be changed. Torque is not displayed on the control panel.



In presets i4 - i5 the torque limit is always on and can not be switched off. The green indicator light on the button is always on.

Two values are displayed next to the **Torque** button: torque (1) and max reached torque (2).

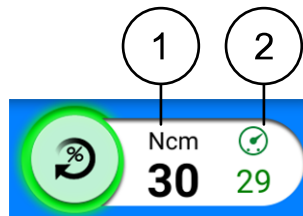

NOTE

The Ncm values displayed on the control panel are accurate only when 20:1 handpieces listed on the previous page are used.

When the instrument is not used, torque (1 in picture above) shows the torque limit. When you drive the instrument, torque shows the current torque value.

Max reached torque (2 in picture above) shows the highest torque value during instrument use. The value is displayed also after you have stopped the instrument and resets when you start driving the instrument again. The max reached torque value also resets when the torque limit or RPM limit is modified, or when you select another preset.

23.5.3 RPM

NOTE

The RPM values are accurate only when 20:1 handpieces are used.



The RPM limit is always on for the Bien-Air MX-i implantology micromotor and can not be switched off. The green indicator light on the button is always on.

23.5.4 Presets

Each user has a personal set of five presets for the Bien-Air MX-i micromotor.

- i1 for pilot drilling
- i2 for implant drilling
- i3 for implant drilling
- i4 for implant tapping
- i5 for implant placement



The **Presets** button displays the currently used preset.

If you want to use another preset than the current, follow the steps below.

1. Activate the micromotor.
2. Press **Presets**.

- In the window that opens, select the desired preset (i1 - i5). You will then automatically be returned to the MX-i window.

The following table presents the default preset settings for the Bien-Air MX-i micromotor. These presets can be modified, see section "Modifying preset values" on page 183.

The tolerance for RPM and torque values is +/- 15%.

Function	Preset i1	Preset i2	Preset i3	Preset i4	Preset i5
RPM range	100 - 2000	100 - 2000	100 - 2000	5 - 85	5 - 85
RPM limit	1200	800	500	30	15
Torque range, Ncm	-	-	-	10 - 70	10 - 70
Torque, Ncm	50	50	50	35	35
Sterile water	On*	On*	On*	On*	N/A
Automatic chip blow	N/A	N/A	N/A	N/A	N/A
Instrument light brightness	100	100	100	100	100

* Sterile water is switched off if a dental unit controlled sterile water system is not connected.

23.6 Morita TORX micromotor



CAUTION

The user must be familiar with endodontic procedures before using the Morita TORX micromotor.

When coupled with the CA-10RC-ENDO 10:1 handpiece, the Morita TORX micromotor can be used together with the Morita Root ZX mini U apex locator to measure the root canal.

When the CA-10RC-ENDO 10:1 handpiece is used, an optimum torque reverse (OTR) function is available when the OTR preset is selected.

Besides the basic micromotor functions, the Morita TORX micromotor has some additional features. These are described below.

23.6.1 Torque

Torque is available for presets a1 - a3, OTR and t1 - t3.



Press **Torque** to enable the torque limit. The green indicator light means that the torque limit is enabled.



In the OTR preset, the torque limit is always on and can not be switched off. The green indicator light on the button is always on.

Presets a1 - a3 and t1 - t3



When the torque limit is enabled, also the drive mode **Autoforward** is enabled. When the torque limit is reached, the micromotor will rotate counter-clockwise (reverse) until the torque value has decreased to 50% of the torque limit value and then return to clockwise rotation.

NOTE

Only the drive mode **Autoforward** is available for the **Morita TORX** micromotor.

NOTE

The foot control can be configured so that you push the left-side knob down to enable/disable the torque function. Contact your Planmeca dealer.

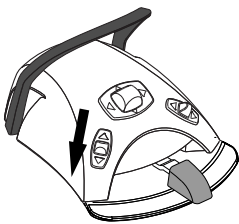

NOTE

Check the indicator light on the control panel to verify that pushing the left-side knob down activates the correct function.

Preset OTR

The OTR preset features an optimum torque reverse (OTR) function. When the torque limit is reached, the micromotor reverses 90°, then moves forward 180° and repeats this movement until the torque limit is no longer reached.

NOTE

The OTR preset should only be used with the **Morita TORX** micromotor coupled with the **CA-10RC-ENDO 10:1** handpiece.

Calibrating OTR

For the OTR function to work properly it must be calibrated at regular intervals when help message H 59 is displayed and when you change to the **CA-10RC-ENDO 10:1** handpiece.

CAUTION

It is possible to drive the micromotor without calibrating the OTR function, but this may affect the operation of the micromotor.



When you select the OTR preset, or when the OTR preset is selected and the OTR function has not been calibrated in the last 30 minutes, help message H 59 is displayed on the screen. Press the **Torque calibration** button on the help message to open the calibration window.



The calibration window can also be opened by pressing the blinking **OTR CAL** button in the instrument window. The button blinks only when calibration is needed.

Calibration window

Torque calibration

OTR torque calibration needed.

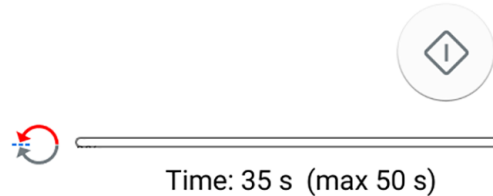

For the OTR torque measurement result to be accurate, always perform calibration when changing the handpiece.



In the calibration window, press **Calibrate** to start OTR torque calibration. The calibration progress is shown in the window.

NOTE

Do not touch the file or let the file touch anything during calibration as this will result in a failed calibration.



You can cancel the calibration by pressing **Close** in the calibration window. Activating another instrument during calibration also cancels the calibration.



When the calibration has been performed successfully, close the calibration window by pressing **OK**.

23.6.2 RPM



Press **RPM limit** to reduce the micromotor's maximum speed to a preset level. The green indicator light means that the RPM limit is on. Press **RPM limit** again to switch the limit off.



As default, the micromotor starts with full speed when preset a1 - a3 or OTR is selected. This is indicated by its **RPM limit** button.

NOTE

In the OTR preset, the RPM limit is always on and can not be switched off.

23.6.3 Apical action



When you select one of the apical presets a1 - a3 or the OTR preset, a small *Apex locator* window automatically opens on the control panel. For information on using the apex locator, see section "Apex locator" on page 146.

When you use presets a1 - a3 or the OTR preset, the instrument preset window also features an **Apical action** button. When an apex measurement is not going on, toggle the button to define what happens when the file tip reaches the point in the root canal defined by the flash bar. The button always shows the current apical action (thus, the symbol on the button changes according to the selected apical action).

NOTE

Reaching the torque limit can also make the micromotor to rotate counter-clockwise.

Apical action

	<p>No apical action</p> <p>When the file tip reaches the point in the root canal defined by the flash bar, this does not induce an action in the micromotor and the micromotor continues to rotate forward.</p>
	<p>Auto stop</p> <p>The micromotor stops when the file tip reaches the point in the root canal defined by the flash bar.</p> <p>When the micromotor has stopped, a thin file can simply be pulled out from the root canal by hand. If a thicker file is used, the micromotor's reverse function must be used to safely remove the file from the root canal.</p>
	<p>Auto forward</p> <p>When the file tip reaches the point in the root canal defined by the flash bar, the micromotor will rotate counter-clockwise (auto reverse) until it has reversed three segments on the apex meter and then return to clockwise direction.</p>

Torque action vs. apical action

Torque action defines the micromotor's rotation when the torque limit is reached.

In presets a1 - a3 the only available torque action for the Morita micromotor is *autoforward*. When the torque limit is enabled and the torque limit reached, the micromotor will rotate counter-clockwise (reverse) until the torque value has decreased to 50% of the torque limit value and then return to clockwise rotation.

In the OTR preset an optimum torque reverse is implemented. When the torque limit is reached, the micromotor repeats a 90° reverse, 180° forward-movement until the torque value has decreased below the set torque limit and then returns to clockwise rotation.

Apical action defines the micromotor's rotation when the file tip reaches the limit depth in the root canal (marked by a flash bar in the window). When the apical action *autoforward* is selected and the limit depth is reached, the micromotor will rotate counter-clockwise (reverse) until it has reversed three segments on the apex meter and then return to clockwise rotation.

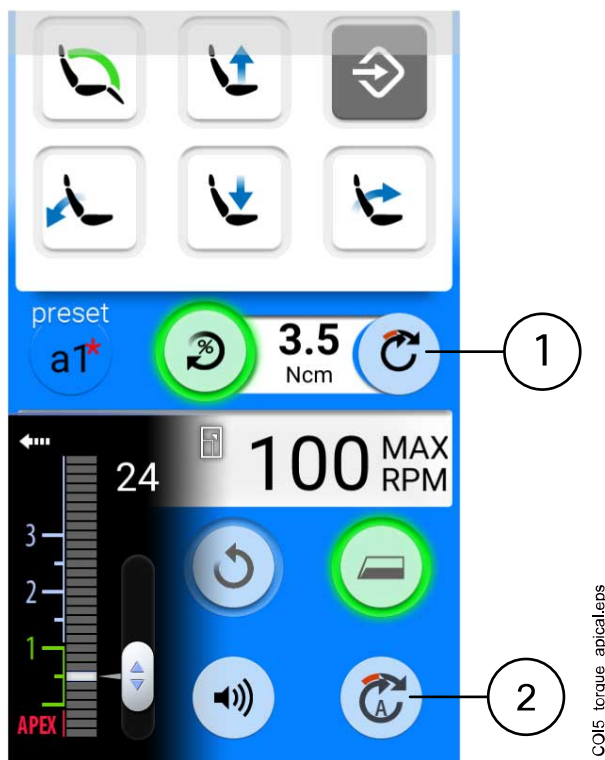

- 1 Torque action
Torque-based transition from reverse to forward rotation
- 2 Apical action
Apical depth-based transition from reverse to forward rotation (when apical action *autofoward* is selected)

23.6.4 Presets



Each user has a personal set of presets for the Morita TORX micromotor. Ten different presets are available and the **Presets** button displays the currently used preset.

If you want to use another preset than the current, follow the steps below.

1. Activate the micromotor.
2. Press **Presets**.
3. In the window that opens, select the desired preset. You will then automatically be returned to the main window.

The presets available for the Morita TORX micromotor are:

1	a1	OTR	t1
2	a2		t2
3	a3		t3

Presets 1 - 3 are generic default presets where the torque limit is not available, a1 - a3 are presets for measuring the apex where the torque limit can be enabled, OTR is a preset for optimum torque reverse where the torque limit and rpm limit are always on, and presets t1 - t3 are torque presets where the torque limit can be enabled.

Presets a1 - a3 and OTR can only be used with the Morita CA-10RC-ENDO 10:1 endo-contra handpiece. This handpiece must not be used with other presets than a1 - a3 and OTR.

CAUTION

Endodontic treatment must only be performed using the Morita TORX micromotor's a1 - a3 and OTR presets and the Morita CA-10RC-ENDO 10:1 handpiece.

CAUTION

Always check the preset settings before using the micromotor.

The table below lists the factory presets for the Morita TORX micromotor. These presets can be modified, see section "Modifying preset values" on page 188.

The tolerance for RPM and torque values is +/- 5%.

NOTE

The torque limit value depends on the handpiece type.

Factory presets for Morita TORX micromotor

Setting	Preset 1 - 3	Preset a1	Preset a2	Preset a3	Preset OTR	Preset t1 - t3
Instrument spray	Spray 1: Water: 50 Air: 80 Spray 2 (Dry): Water: 0 Air: 80 Default: Spray off	Disabled	Disabled	Disabled	Disabled	Spray 1: Water: 50 Air: 80 Spray 2 (Dry): Water: 0 Air: 80 Default: Spray off
Sterile water	Available	N/A	N/A	N/A	N/A	Available
Cooling air	Enabled	Disabled	Disabled	Disabled	Disabled	Enabled
Automatic chip blow	On/Off Water: 0 Air: 60 Default: Chip blow on	Disabled	Disabled	Disabled	Disabled	On/Off Water: 0 Air: 60 Default: Chip blow on
Manual chip blow	Can be configured to be used from foot control Default: On	N/A	N/A	N/A	N/A	Can be configured to be used from foot control Default: On
Rotation	Forward/Reverse Default: Forward rotation	Forward/Reverse Default: Forward rotation	Forward/Reverse Default: Forward rotation	Forward/Reverse Default: Forward rotation	Forward	Forward/Reverse Default: Forward rotation

Factory presets for Morita TORX micromotor

Setting	Preset 1 - 3	Preset a1	Preset a2	Preset a3	Preset OTR	Preset t1 - t3
Instrument light	On/Off Brightness: 100 Default: Instrument light on	N/A	N/A	N/A	N/A	On/Off Brightness: 100 Default: Instrument light on
Power curve	Linear/Full Default: Linear	Linear/Full Default: Full	Linear/Full Default: Full	Linear/Full Default: Full	Full	Linear/Full Default: Linear
Rpm	Value range: 100 - 40 000 Default: 40 000	Value range: 100 - 1000	Value range: 100 - 1000	Value range: 100 - 1000	Values: 100, 300, 500	Value range: 100 - 2000
Rpm limit	Enabled/Disabled Value range: 100 - 36 000 rpm Default: Disabled	Enabled Value range: 100 - 1000 rpm Default: 400 rpm	Enabled Value range: 100 - 1000 rpm Default: 400 rpm	Enabled Value range: 100 - 1000 rpm Default: 1000 rpm	Enabled Values: 100, 300, 500 rpm Default: 300 rpm	Enabled Value range: 100 - 2000 rpm Default: 2000 rpm
Torque limit	Disabled	Enabled/Disabled; autoforward Value range: 0.5 - 5.0 Ncm Default: Enabled, 1.0 Ncm	Enabled/Disabled; autoforward Value range: 0.5 - 5.0 Ncm Default: Enabled, 2.0 Ncm	Enabled/Disabled; autoforward Value range: 0.5 - 5.0 Ncm Default: Disabled	Enabled; optimum torque reverse Value range: 0.2 - 1.0 Ncm Default: 0.2 Ncm	Enabled; autoforward Value range: 0.5 - 2.5 Ncm Default: Enabled, 2.5 Ncm
Handpiece	1:1	10:1	10:1	10:1	10:1	1:1
Apical measurement	N/A	Available	Available	Available	Available	N/A
Apical actions	N/A	Off/ Stop/ AutoForward Default: AutoForward	Off/ Stop/ AutoForward Default: AutoForward	Off/ Stop/ AutoForward Default: None	Off/ Stop/ AutoForward Default: None	N/A
Apical beep volume	N/A	On/off Default: On	On/off Default: On	On/off Default: On	On/off Default: On	N/A

23.7 Apex locator

The Morita Root ZX mini U apex locator can be used as a guide when measuring the root canal. It is available for the Morita TORX micromotor, the CA-10RC-ENDO 10:1 handpiece and for hand files.

The apex locator can be operated from the dental unit's control panel. More detailed information on how to measure the root canal can be found in the operation instructions provided by Morita.

**WARNING**

Do not simultaneously touch the patient and the USB ports, or any electrical connectors of external instrument modules.

**WARNING**

Do not use this apex locator on patients who have a pacemaker or ICD.

**WARNING**

Do not use this apex locator in conjunction with an electric scalpel.

CAUTION

The Morita Root ZX mini U is not recommended for use with children under 12 years of age.

CAUTION

Always check the measurement with an X-ray. In some cases, an accurate measurement cannot be made, for example, because of the canal shape.

NOTE

When the file is in the root canal and apex measurement is going on (>2 bars on the meter scale are blinking), the control panel is locked.

23.7.1 Before using apex locator

CAUTION

Before performing endodontic treatments with the Morita TORX micromotor and the CA-10RC-ENDO 10:1 handpiece, read the documentation provided by Morita.

CAUTION

Before using the Morita Root ZX mini U apex locator, read the documentation provided by Morita.

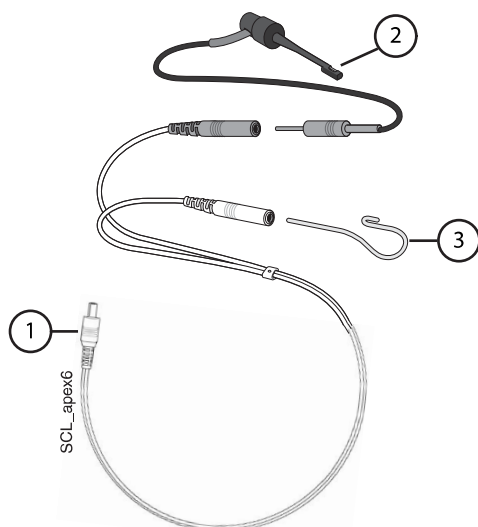

1. Probe cord	The probe cord is plugged into the jack on the back of the instrument console.
2. File holder	If you are using a hand file with the apex locator, insert the file holder's grey male plug into the grey female connector on the probe cord. If you are using the Morita TORX micromotor and the CA-10RC-ENDO 10:1 handpiece with the apex locator, do not use the file holder. Leave the grey female connector on the probe cord hanging.
3. Contrary electrode	Insert the contrary electrode into the white female connector on the probe cord.

NOTE

Always grip the connector to connect/disconnect the probe cord. Never pull or yank on the cord itself.

Before treating a patient:

- Make sure that the probe cord is securely plugged into the jack on the back of the instrument console.

Instrument console with hanging-tube instruments

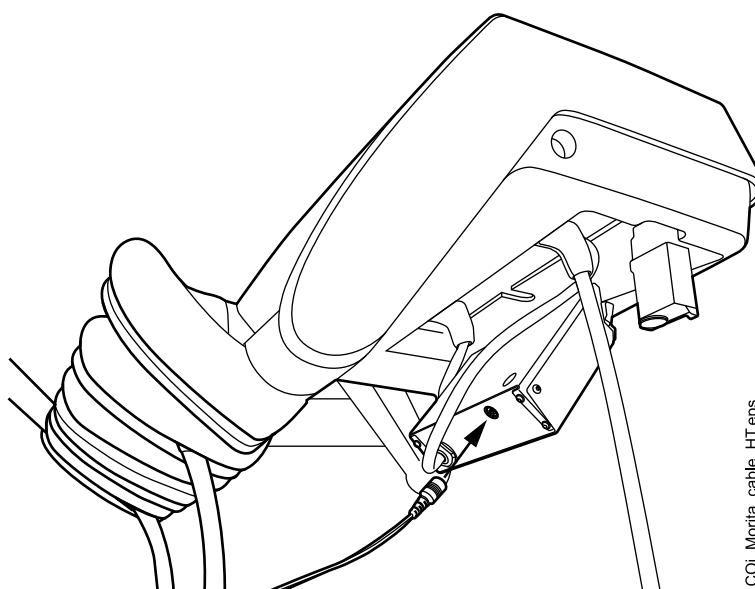

COI_Morita_cable_HT.eps

Instrument console with balanced instrument arms

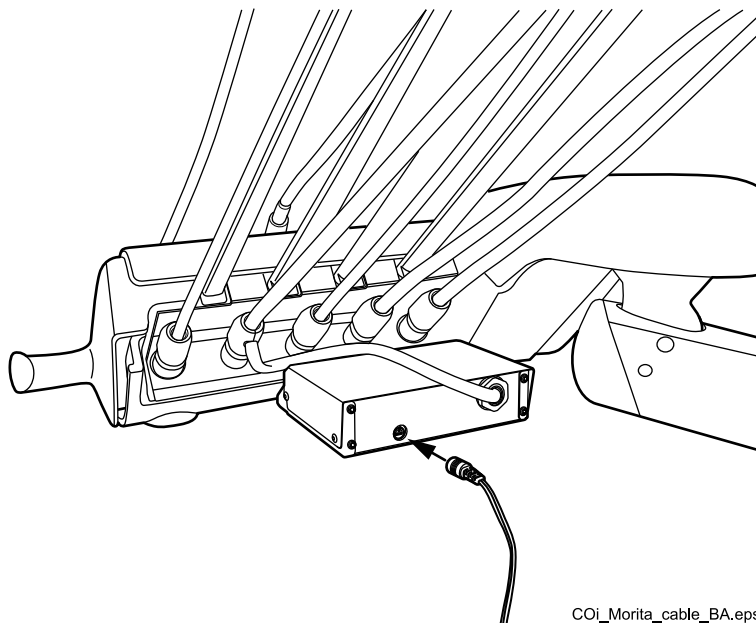

COI_Morita_cable_BA.eps

- Check that the file holder and contrary electrode are properly connected to the probe cord.
- If you are using a hand file with the apex locator, touch the metal part of the file holder with the contrary electrode. Check that all the meter indicator bars in the *Apex locator* window light up.

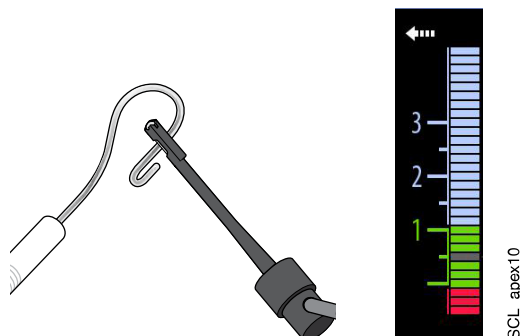

SCL_apex10

If the indicator bars do not appear normally, stop using the device and contact your Planmeca dealer.

- If you are using the Morita TORX micromotor and the CA-10RC-ENDO 10:1 handpiece with the apex locator, touch the file with the contrary electrode. Check that all the meter indicator bars in the *Apex locator* window light up.

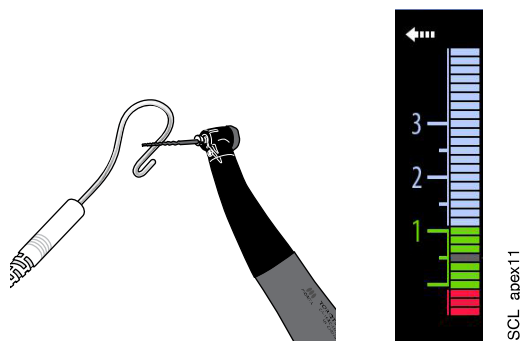

SCL_apex11

If the indicator bars do not appear normally, stop using the device and contact your Planmeca dealer.

23.7.2 Using apex locator

The Morita Root ZX mini U apex locator can be used both with hand files and with the Morita TORX micromotor and the CA-10RC-ENDO 10:1 handpiece.





If you are using hand files, press **Apex locator** to open the *Apex locator* window.

NOTE

If the Apex locator button is not visible in your control panel's swipe menu, you must add it. See section "Organising items on control panel" on page 175.

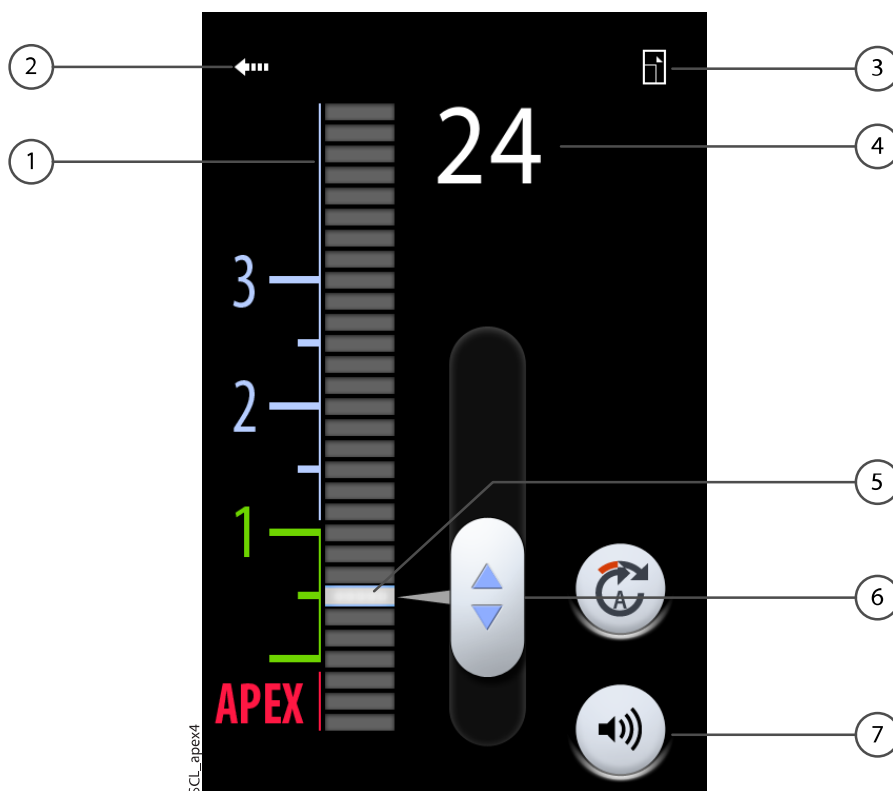
If you are using the Morita TORX micromotor and the CA-10RC-ENDO 10:1 handpiece, the *Apex locator* window automatically opens on the control panel when you select one of the apical presets a1 - a3 or the OTR preset.



1	<p>Meter scale for estimating the location of the apex.</p> <p>The numbers on the meter scale do not represent the actual distance to the apex and should be used only as an estimate of the distance.</p> <p>The numerals 1, 2 and 3 do not represent length in millimetres.</p>
2	<p>Press the arrow to close the <i>Apex locator</i> window.</p> <p>You can open the window again by pressing the Apex locator button. </p>
3	<p>Press to minimise the window.</p> <p>When the window is minimised, press the equivalent button to maximise the window.</p>

4	Indicates the number of bars between the file tip and the flash bar.
5	Flash bar
6	Handle for dragging flash bar to desired location
7	Sound button for turning off/on the sound of the apex locator. The Sound button only turns off the sound of the apex locator. It has no effect on the beep signals of the torque function. We recommend that you keep the sound on at all times.

The flash bar is a reference for measurement and should be set between 2 and apex. Set the flash bar by dragging the handle to the desired location.

When you insert the file into the root canal, the flash bar starts blinking. When the file tip reaches the point in the root canal designated by the flash bar, the flash bar stops blinking and stays on.

As you progress down the root canal, a beep signal starts to sound when the file tip goes below 2 on the meter scale. For the 5 first bars, the beep signal is slow, after which the beep signal becomes fast, and finally becomes continuous when it reaches the flash bar.



- 1 Slow beep signal
- 2 Fast beep signal
- 3 Continuous signal

If the flash bar has been set within the 5 bars below 2 on the meter scale, the beep signal is slow at first and becomes continuous when the file tip reaches the flash bar. There is no fast beep signal.



1. Slow beep signal
2. Continuous signal

If the flash bar has been set at 2 on the meter scale, the only signal that is heard is the continuous signal when the file tip reaches the flash bar.



1. Continuous signal

23.7.3 Testing apex locator function

About this task

The apex locator function must be tested weekly.

NOTE

While the test is going on, the control panel is locked.

Steps



1. Open the *Apex locator* window either by pressing the **Apex locator** button or by activating the Morita TORX micromotor and selecting one of the apex presets (a1 - a3).
2. Insert the tester into the jack on the back of the instrument console.
Instrument console with hanging-tube instruments

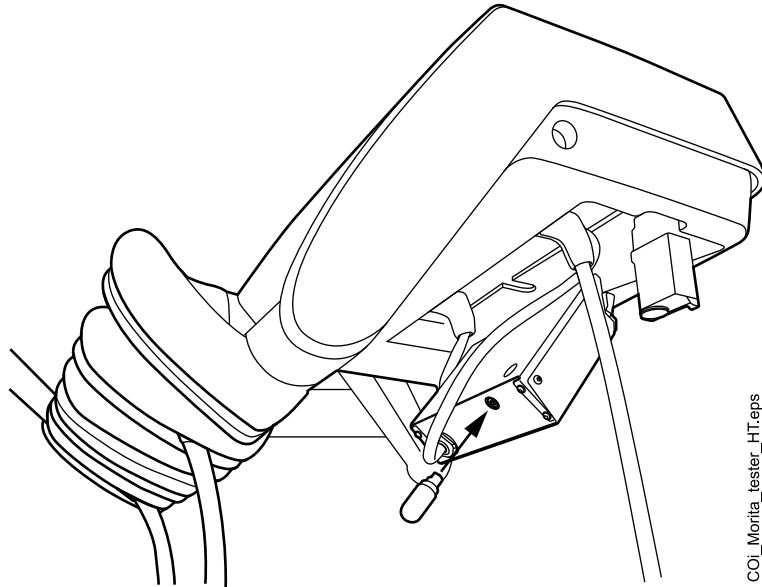

COI_Morita_tester_HT.eps

Instrument console with balanced instrument arms

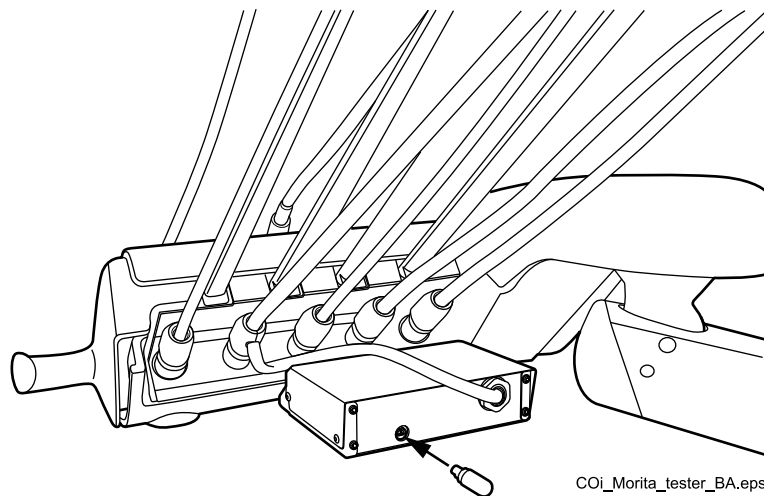

COI_Morita_tester_BA.eps

3. Check that the meter indicates within 3 bars above or below 1.
The meter may jump when the tester is inserted. If it does, wait for about one second until the meter stabilises and then check the reading.
If the reading is 4 or more bars away from 1, the unit will not make an accurate measurement. Contact your Planmeca dealer.

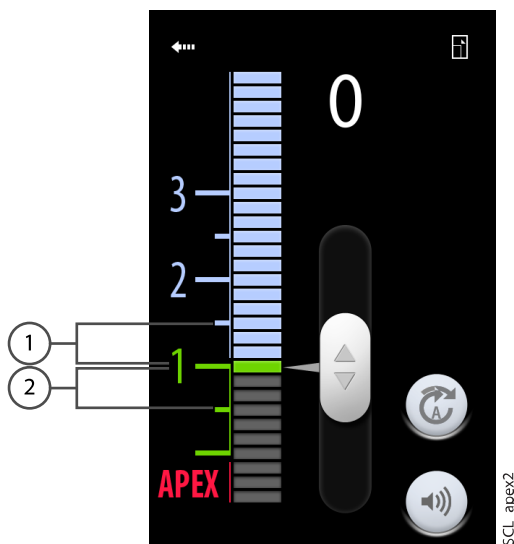

- 1 3 bars above 1
- 2 3 bars below 1

23.8 Turbine

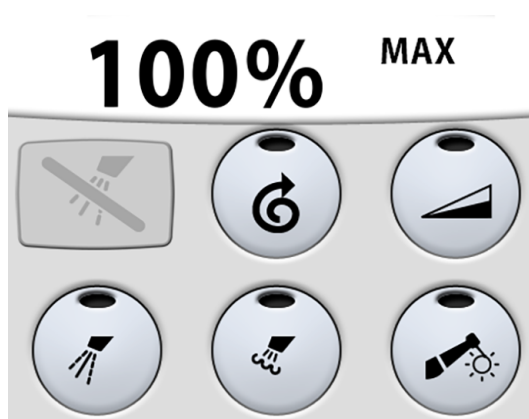

The turbines supplied by Planmeca have a built-in backflow prevention system, which protects the water used in the instrument from contamination.

CAUTION

A power cut will shut down the software-controlled backflow prevention system. If you are using a turbine without a built-in backflow prevention system, contaminated water can enter into the turbine and turbine hose in the event of a power cut.

23.8.1 Speed/power

Standard pedal: To drive the instrument, push the foot control pedal to the right or to the left.

Wide pedal: To drive the instrument, push the foot control pedal down.

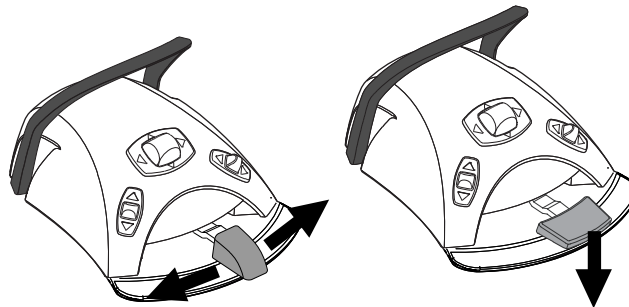

Pushing the pedal further to the right/left or down will increase the speed or power of the instrument. As you push the pedal, the power output is displayed on the control panel. The normal range is 5 - 100%.

To stop the instrument, allow the pedal to return to the rest position.

CAUTION

Ensure that the pedal is in rest position when you activate the instrument.

NOTE

The speed/power level depends on the instrument.

23.8.2 Quickstart

The turbine will start with maximum speed if the quickstart is enabled.

When quickstart is enabled, the indicator light on the control panel button is green.



Control panel: When the instrument is active, but not operated, press **Quickstart** to enable/disable the quickstart.

NOTE

The foot control can be configured so that you push the left-side knob down to enable/disable the quickstart. Contact your Planmeca dealer.



NOTE

Check the indicator light on the control panel to verify that pushing the left-side knob down activates the correct function.

23.8.3 Instrument spray

The instrument cooling spray setting can be selected to be water & air, air or no spray.

The spray flow rate can be programmed. See section "Instrument spray" on page 178.



The amounts of water and air for the currently used spray type are displayed on the control panel.



When sterile water is used, you can select between sterile water spray and spray off. Sterile water is indicated by a Sterile water symbol and the indicator light blinks green on the **Instrument spray** button.

Sterile water is meant to be used together with an air scaler.

For instructions on how to enable/disable the sterile mode, see section "Enabling/disabling sterile water mode" on page 179.



Press **Instrument spray** once to switch on the water & air spray. You will hear two short signal tones. Additionally, a green indicator light shows that the water & air spray is switched on.



Press **Instrument spray** a second time to switch the air spray on. You will hear one short signal tone. Additionally, a yellow indicator light shows that the air spray is switched on.



Press **Instrument spray** a third time to switch off the instrument cooling spray. You will hear one long signal tone. Additionally, the indicator light goes out.

Alternatively, you can select the spray setting with the foot control. The indicator lights on the control panel are lit accordingly.

Standard pedal: Push the pedal down briefly to select the spray setting.

Wide pedal: Push the pedal briefly to the left to select the spray setting.

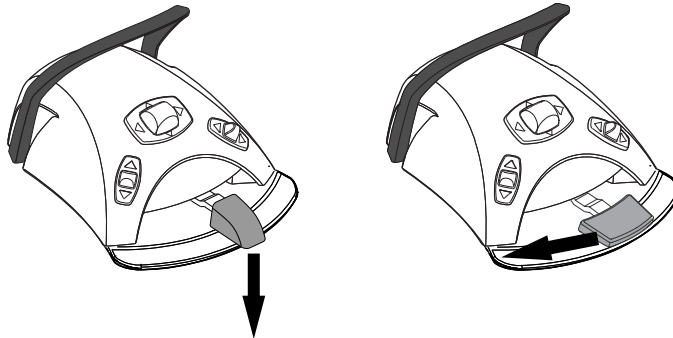

Push the pedal once to switch on the water & air spray. You will hear two short signal tones.

Push the pedal again to switch on the air spray. You will hear one short signal tone.

Push the pedal a third time to switch off the instrument spray. You will hear one long signal tone.

NOTE

The foot control can also be configured so that you push the left-side knob down to select a different spray setting. Contact your Planmeca dealer.



NOTE

Check the indicator light on the control panel to verify that pushing the left-side knob down activates the correct function.

NOTE

The spray must be switched off when using an instrument without a waterline inside the handpiece.

NOTE

The instrument spray operated with the foot control can be disabled in the service mode, in which case you can switch the spray on and off only from the control panel. Contact your Planmeca dealer.

23.8.4 Speed/power limit

When the turbine's speed/power limit is on and the preset value is, for example, 50%, the foot control pedal movement controls the speed/power between 5 - 50% instead of the normal range of 5 - 100%. The preset maximum value is displayed on the control panel when the turbine is picked up from the instrument console.

When the speed/power limit is on, the indicator light on the control panel button is green.



Control panel: Press **Turbine speed/power limit** to reduce the turbine's speed or power to a preset level. Press **Turbine speed/power limit** again to switch the speed/power limit off.

NOTE

The foot control can be configured so that the turbine's speed or power is limited to a preset level when you push the left-side knob down. Contact your Planmeca dealer.

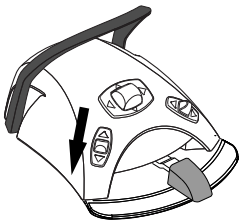
**NOTE**

Check the indicator light on the control panel to verify that pushing the left-side knob down activates the correct function.

NOTE

The speed/power limit can be programmed. See section "Instrument speed/power limit" on page 178.

NOTE

The turbine speed/power limit does not affect the air driven instruments for which quickstart has been selected.

NOTE

Note that the speed/power limit depends on the instrument.

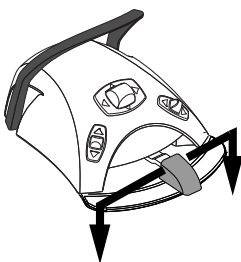
23.8.5 Momentary spray

When you are driving the instrument, you can activate the momentary spray by pressing the foot control pedal down. The spray will continue until you remove your foot from the pedal.

NOTE

The momentary spray can be enabled and configured in the service mode, contact your Planmeca dealer.

NOTE

The momentary spray can not be activated with the wide foot control pedal.

23.8.6 Automatic chip blow

When the automatic chip blow is on, the indicator light on the control panel button is on and two short blows of water, air, or both will occur after the instrument is stopped.



Control panel: Press **Chip blow** to switch the automatic chip blow on or off.

NOTE

The foot control can be configured so that you push the left-side knob down to switch the automatic chip blow on/off. Contact your Planmeca dealer.

NOTE

Check the indicator light on the control panel to verify that pushing the left-side knob down activates the correct function.



The type of chip blow can be programmed, see section "Automatic chip blow" on page 180.

23.8.7 Manual chip blow

Standard pedal: You can temporarily activate the manual chip blow by pushing and holding down the pedal.

Wide pedal: You can temporarily activate the manual chip blow by pushing and holding the pedal to the right.

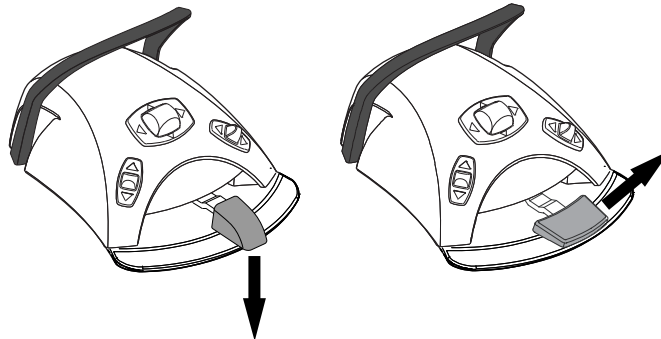

The flow of air will continue until you remove your foot from the pedal.

NOTE

The type of manual chip blow does not depend on the type of the automatic chip blow, but is always dry. The manual chip blow can be set to be dependent on programming; contact your Planmeca dealer.

23.8.8 Instrument light

When the instrument light is on, the indicator light on the control panel button is green.

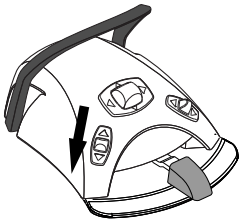

Control panel: Press **Instrument light** to switch the instrument light on/off.

**NOTE**

The foot control can be configured so that you push the left-side knob down to switch the instrument light on/off. Contact your Planmeca dealer.

NOTE

Check the indicator light on the control panel to verify that pushing the left-side knob down activates the correct function.

The instrument light intensity can be programmed, see section "Instrument light" on page 180.

23.9 Scaler

CAUTION

Do not use the scaler on patients with cardiac pacemakers. The scaler can cause disturbance on the pacemaker's function.

NOTE

A scaler requires additional electronics and the scaler type can not be changed without changing electronics.

23.9.1 Speed/power

Standard pedal: To drive the instrument, push the foot control pedal to the right or to the left.

Wide pedal: To drive the instrument, push the foot control pedal down.

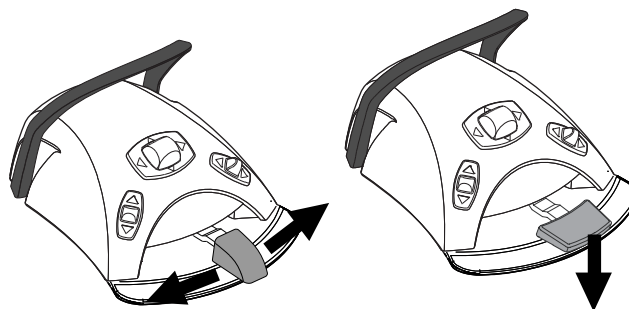

Pushing the pedal further to the right/left or down will increase the speed or power of the instrument. As you push the pedal, the power output is displayed on the control panel.

To stop the instrument, allow the pedal to return to the rest position.

CAUTION

Ensure that the pedal is in rest position when you activate the instrument.

NOTE

The speed/power level depends on the instrument.

23.9.2 Instrument spray

The spray setting for the scaler can be selected to be water 1, water 2 or no spray.

The amount of water that runs through the scaler can be set separately for water 1 and 2, see section "Instrument spray" on page 178.



The amount of water and the spray water number (1 or 2) are displayed on the control panel.



When sterile water is used, you can select between sterile water spray and spray off. Sterile water is indicated by a Sterile water symbol and the indicator light blinks green on the **Instrument spray** button.

For instructions on how to enable/disable the sterile mode, see section "Enabling/disabling sterile water mode" on page 179.



Press **Instrument spray** once to switch on water 1. You will hear two short signal tones. Additionally, a green indicator light shows that water 1 is switched on.



Press **Instrument spray** a second time to switch on water 2. You will hear one short signal tone. Additionally, a yellow indicator light shows that water 2 is switched on.



Press **Instrument spray** a third time to switch off the instrument spray. You will hear one long signal tone. Additionally, the indicator light goes out.

Alternatively, you can select the spray setting with the foot control. The indicator lights on the control panel are lit accordingly.

Standard pedal: Push the pedal down briefly to select the spray setting.

Wide pedal: Push the pedal briefly to the left to select the spray setting.

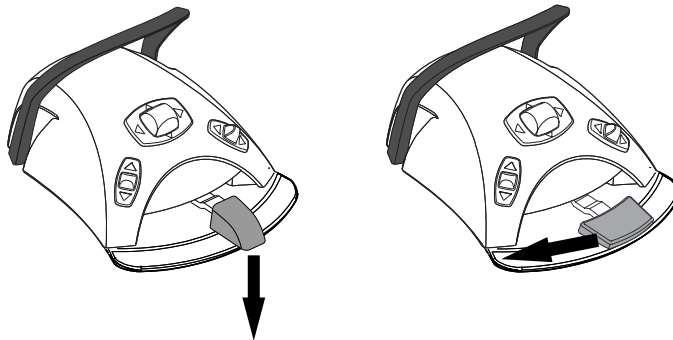

Push the pedal once to switch on water 1. You will hear two short signal tones.

Push the pedal again to switch on water 2. You will hear one short signal tone.

Push the pedal a third time to switch off the instrument spray. You will hear one long signal tone.

NOTE

The foot control can also be configured so that you push the left-side knob down to select a different spray setting. Contact your Planmeca dealer.

**NOTE**

Check the indicator light on the control panel to verify that pushing the left-side knob down activates the correct function.

NOTE

The instrument spray operated with the foot control can be disabled in the service mode, in which case you can switch the spray on and off only from the control panel. Contact your Planmeca dealer.

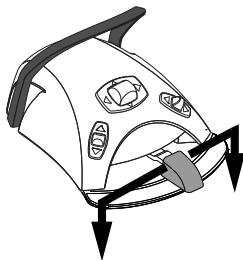
23.9.3 Momentary spray

When you are driving the instrument, you can activate the momentary spray by pressing the foot control pedal down. The spray will continue until you remove your foot from the pedal.

NOTE

The momentary spray can be enabled and configured in the service mode, contact your Planmeca dealer.

NOTE

The momentary spray can not be activated with the wide foot control pedal.

23.9.4 Satelec Newtron scaler

The Satelec Newtron scaler and the Satelec Newtron LED scaler have four modes:

- periodontics; power range 1 - 3
- endodontics; power range 3 - 5
- scaling; power range 5 - 8
- conservative dentistry; power range 8 - 10.

A coloured band at the base of the scaler tip helps you choose the proper scaler mode on the dental unit:

- Green - periodontics
- Yellow - endodontics
- Blue - scaling
- Orange - conservative dentistry (restoration)

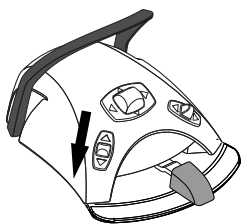

When the scaler is the active instrument, the scaler mode can be changed by pressing **Power**.

**NOTE**

The foot control can be configured so that you push the left-side knob down to change the scaler mode. Contact your Planmeca dealer.

NOTE

Check the scaler mode symbol on the control panel to verify that pushing the left-side knob down activates the correct function.

23.9.5 LM scaler**CAUTION**

Keep the patient's lips, cheeks and tongue out of the way of the activated scaler tip, as contact may cause burns.



The LM scaler has three modes:

- low (0 - 40)
- medium (0 - 70)
- full (0 - 100).

Start with the low mode and, if needed, gradually change to medium and full mode.



When the scaler is the active instrument, the scaler mode can be changed by pressing **Power**.

NOTE

The foot control can be configured so that you push the left-side knob down to change the scaler mode. Contact your Planmeca dealer.

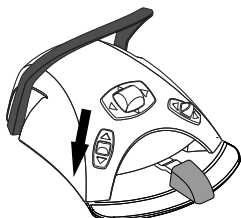
**NOTE**

Check the scaler mode symbol on the control panel to verify that pushing the left-side knob down activates the correct function.

23.9.6 Planmeca Piezon LED (EMS) scaler

The Planmeca Piezon LED (EMS) scaler has three modes:

- endodontics (**Endo**); power range 1 - 50
- scaling; power range 1 - 100
- restoration; power range 50 - 100.



When the scaler is the active instrument, the scaler mode can be changed by pressing **Power**.

**NOTE**

The foot control can be configured so that you push the left-side knob down to change the scaler mode. Contact your Planmeca dealer.

NOTE

Check the scaler mode symbol on the control panel to verify that pushing the left-side knob down activates the correct function.

23.9.7 Instrument light

When the instrument light is on, the indicator light on the control panel button is green.



Control panel: Press **Instrument light** to switch the instrument light on/off.

NOTE

The foot control can be configured so that you push the left-side knob down to switch the instrument light on/off. Contact your Planmeca dealer.

**NOTE**

Check the indicator light on the control panel to verify that pushing the left-side knob down activates the correct function.

The instrument light intensity can be programmed, see section "Instrument light" on page 180.

23.10 Planmeca Lumion Plus polymerisation light**CAUTION**

The polymerisation light generates optical radiation and proper safety measures should be taken when using the instrument. For detailed information, please refer to OEM documentation.

CAUTION

Do not use the polymerisation light on patients with cardiac pacemakers. The polymerisation light can cause disturbance on the pacemaker's function.

NOTE

When the polymerisation light is taken from the holder in the instrument console and returned to it, the operating light's composite mode is switched on. This feature is configurable; contact your Planmeca dealer.

To start the polymerisation cycle, first select the desired curing mode by pressing the navigation button on the handpiece. Then, start the polymerisation cycle by pressing the start button on the handpiece.

The polymerisation cycle can be interrupted by pressing the start button again.

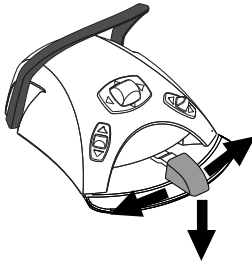

To start the polymerisation cycle with the foot control, first select the desired curing mode by pressing the navigation button on the handpiece. Then, push the foot control pedal to the right or to the left or down to start the polymerisation cycle.

The polymerisation cycle can be interrupted by pushing the foot control pedal to the right or to the left or down.

The length of the cycle is programmable, see section "Planmeca Lumion Plus polymerisation light" on page 191.

When the polymerisation light is activated, the length of the polymerisation cycle is displayed on the control panel. When you start the cycle, you will hear a signal tone. This signal tone is repeated every 10 seconds, and also at 5 seconds. The progress of the polymerisation cycle is displayed on the control panel.

Independent mode

The Planmeca Lumion Plus polymerisation light can also be operated in the independent mode. The independent mode is typically used when the Planmeca Lumion Plus polymerisation light is attached to the assistant element, but the independent mode can also be configured to be used on the dentist side (the configuration is performed by a Planmeca service technician).

When the Planmeca Lumion Plus polymerisation light is in the independent mode, it can only be controlled by the buttons on the instrument itself, not over the control panel or the foot control.

To start the polymerisation cycle in the independent mode, first select the desired curing mode by pressing the navigation button on the handpiece. Then, briefly press the start button on the handpiece to start a 10-second exposure, or press and hold the start button for 2 seconds to start a 20-second exposure. The polymerisation cycle can be interrupted by pressing the start button.

In the 10-second cycle, a signal tone is heard at the beginning and the end of the cycle. In the 20-second cycle, a signal tone is heard as the cycle starts, after 2 seconds to confirm the start of the 20-second cycle, after 10 seconds and at the end of the cycle.

NOTE

When the Planmeca Lumion Plus polymerisation light is in the independent mode, it can not be controlled over the foot control.

Refer to the Planmeca Lumion Plus manual of use and maintenance.

23.11 Intraoral camera and Planmeca Romexis

For detailed information on KaVo DIAGNOcam Vision Full HD, see OEM documentation.

For detailed information on Planmeca Somia, please refer to *Planmeca Somia user's manual*.

Planmeca Somia handpiece

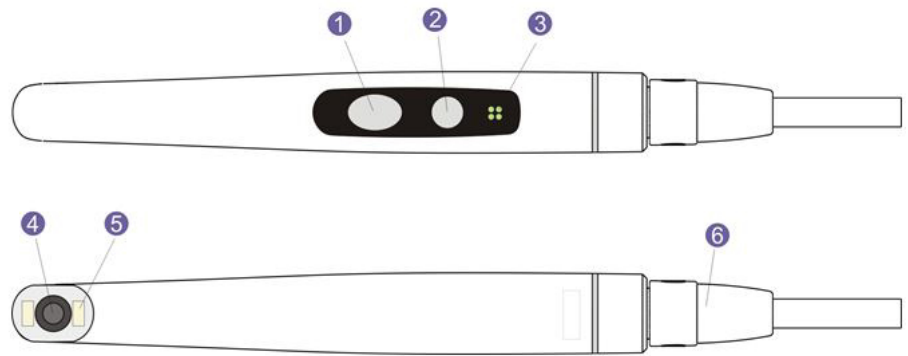

1. Image control button
2. Power/macro button
3. Indicator light
4. Camera lens
5. Light source (LED)
6. USB cable

Prerequisites

- The intraoral camera must be connected to the USB port.
When the intraoral camera is placed in the instrument console, it is connected to the USB port on the underside of the instrument console.
When the intraoral camera is placed in the suction holder, it is connected to the USB port on the cuspidor.
- Planmeca Romexis software must be installed and the connection between it and the dental unit must be enabled. When Planmeca Romexis is running, the intraoral camera is continuously connected to the software.

After you have saved the images

Once you have saved the images, you can browse through them in the Planmeca Romexis Image browser. Press the **Done** button at the bottom of the intraoral camera window in Planmeca Romexis to move to the Image browser. For more information on the Image browser, see the *Planmeca Romexis user's manual*.

23.11.1 Intraoral camera placed in instrument console

Starting intraoral camera

Before you turn on the intraoral camera, select the patient in Planmeca Romexis. For instructions, see *Planmeca Romexis user's manual*, section *Opening patients*.

To turn on the intraoral camera, pick it up from the instrument console.

Alternatively, you can turn the intraoral camera on by pressing any of the buttons on the camera handpiece.

NOTE

If you turn on the intraoral camera from the buttons on the handpiece, the camera can not be operated from the dental unit's foot control.

When the intraoral camera turns on,

- the indicator light on the Planmeca Somia handpiece turns blue,
- the indicator light on the KaVo DIAGNOcam Vision Full HD turns on,
- you will hear a short sound signal,
- the Planmeca Romexis intraoral camera view is displayed on the monitor,
- the text “Intraoral camera active” is displayed on the dental unit's control panel.

Once the intraoral camera is activated, you can operate it

- from the dental unit's foot control, if the camera has been turned on by picking it up from the instrument console
- from the camera handpiece, or
- remotely from the Planmeca Romexis user interface.

You can use the camera in normal or macro mode, as well as freeze and save the image. The LED on the handpiece is turned on and off simultaneously with the intraoral camera.

Macro on/off

The macro mode is only available for Planmeca Somia.

A short sound signal indicates that the macro mode is turned on/off. When the macro mode is on, autofocus is off and the indicator light on the handpiece is lilac.

Interface	Action
Planmeca Somia handpiece	Press the Power/macro button to turn the macro mode on/off.

Freezing/unfreezing image

A short sound signal indicates the freeze/unfreeze of an image. When you unfreeze the image, the camera goes back to live stream.

When the image is frozen, the indicator light on the Planmeca Somia handpiece is green. During the live stream, it is blue.

Interface	Action
Foot control	In Planmeca Compact i dental units, push the foot control pedal to the left or right to freeze/unfreeze the image.
Planmeca Somia handpiece	There are two ways to freeze/unfreeze the image from the handpiece. <ul style="list-style-type: none"> • Press the Image control button halfway and hold it to freeze the image. When you release the button, the image unfreezes. • Press the Image control button all the way down and release it to freeze the image. To unfreeze the frozen image, either press the Image control button halfway and then release it, or press the button all the way down and release it.
KaVo DIAGNOcam Vision Full HD handpiece	See OEM documentation.

Interface	Action
Planmeca Romexis	Press the Freeze button to freeze the image. Press the Resume button to unfreeze the image. The buttons are located at the bottom of the intraoral camera window.

Saving image

A frozen image can be saved from the dental unit, the handpiece and Planmeca Romexis. From the handpiece you can save an image also without freezing the image first.

A long sound signal indicates that an image is saved. After the image is saved, the camera goes back to live stream.

When the image is being saved, the indicator light on the Planmeca Somia handpiece blinks orange. When the camera goes back to live stream, the indicator light is blue.

Interface	Action
Foot control	In Planmeca Compact i dental units, when the image is frozen, briefly push the foot control pedal down to save the image.
Planmeca Somia handpiece	Press the Image control button for two seconds. Note! When saving an image from the handpiece, you can, but do not have to freeze the image first.
KaVo DIAGNOcam Vision Full HD handpiece	See OEM documentation.
Planmeca Romexis	When the image is frozen, press the Save button at the bottom of the intraoral camera window.

Turning off intraoral camera

When you return the intraoral camera to the instrument console, the camera is automatically turned off and the indicator light on the handpiece goes off.

The intraoral camera can also be turned off by

- closing the Planmeca Romexis intraoral camera view, or by
- not using the intraoral camera for 300 seconds.

In addition, Planmeca Somia can be turned off by pressing the **Power/macro** button on the handpiece for two seconds.

23.11.2 Intraoral camera placed in suction holder

Starting intraoral camera

Before you turn on the intraoral camera, select the patient in Planmeca Romexis. For instructions, see *Planmeca Romexis user's manual*, section *Opening patients*. Then, start the camera from the dental unit.

1. Pick up the camera from the suction holder (Flexy holder).



2. Activate the intraoral camera with the foot control by pushing the right-side knob up (factory default setting).

The dental unit can also be configured so that the intraoral camera is activated when you push the foot control's left-side knob up or when you press the **Flexy** button. Contact your Planmeca dealer.

The indicator light on the handpiece turns blue (Planmeca Somia) / turns on (KaVo DIAGNOcam Vision Full HD). The text "Intraoral camera active" is displayed on the dental unit's control panel and the Planmeca Romexis intraoral camera view is displayed on the monitor.

Once the intraoral camera is activated, you can operate it

- from the dental unit's foot control,
- from the camera handpiece, or
- remotely from the Planmeca Romexis user interface.

You can use the camera in normal or macro mode (Planmeca Somia only), as well as freeze and save the image. The LED on the handpiece is turned on and off simultaneously with the intraoral camera.

Macro on/off

The macro mode is only available for Planmeca Somia.

A short sound signal indicates that the macro mode is turned on/off. When the macro mode is on, autofocus is off and the indicator light on the handpiece is lilac.

Interface	Action
Handpiece	Press the Power/macro button to turn the macro mode on/off.

Freezing/unfreezing image

A short sound signal indicates the freeze/unfreeze of an image. When you unfreeze the image, the camera goes back to live stream.

When the image is frozen, the indicator light on the Planmeca Somia handpiece is green. During the live stream, it is blue.

Interface	Action
Foot control	In Planmeca Compact i dental units, push the foot control pedal to the left or right to freeze/unfreeze the image.
Planmeca Somia handpiece	There are two ways to freeze/unfreeze the image from the handpiece. <ul style="list-style-type: none"> • Press the Image control button halfway and hold it to freeze the image. When you release the button, the image unfreezes. • Press the Image control button all the way down and release it to freeze the image. To unfreeze the frozen image, either press the Image control button halfway and then release it, or press the button all the way down and release it.
KaVo DIAGNOcam Vision Full HD handpiece	See OEM documentation.

Interface	Action
Planmeca Romexis	Press the Freeze button to freeze the image. Press the Resume button to unfreeze the image. The buttons are located at the bottom of the intraoral camera window.

Saving image

A frozen image can be saved from the dental unit, the handpiece and Planmeca Romexis. From the handpiece you can save an image also without freezing the image first.

A long sound signal indicates that an image is saved. After the image is saved, the camera goes back to live stream.

When the image is being saved, the indicator light on the Planmeca Somia handpiece blinks orange. When the camera goes back to live stream, the indicator light is blue.

Interface	Action
Foot control	In Planmeca Compact i dental units, when the image is frozen, briefly push the foot control pedal down to save the image.
Planmeca Somia handpiece	Press the Image control button for two seconds. Note! When saving an image from the handpiece, you can, but do not have to freeze the image first.
KaVo DIAGNOcam Vision Full HD handpiece	See OEM documentation.
Planmeca Romexis	When the image is frozen, press the Save button at the bottom of the intraoral camera window.

Turning off intraoral camera

Deactivate the intraoral camera from the dental unit when you have finished working with it.

Deactivate the intraoral camera with the foot control by pushing the right-side knob up (factory default setting).

The dental unit can also be configured so that the intraoral camera is deactivated when you push the foot control's left-side knob up or when you press the **Flexy** button. Contact your Planmeca dealer.

When the camera is deactivated, the indicator light on the handpiece goes off. Return the intraoral camera to its holder.

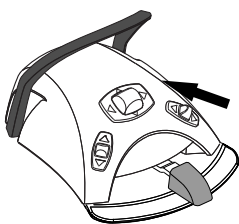

23.12 Planmeca intraoral scanner

The Planmeca intraoral scanner is used together with Planmeca Romexis and the Planmeca Romexis CAD/CAM module. The scanner is mainly operated with the software, but to make the scanning procedure easier, some of the operations can also be performed from the dental unit's foot control.

The intraoral scanner is placed in the Flexy holder.

CAUTION

Make sure that you attach the intraoral scanner connector the right way into the USB 3.0 port for the scanner on the cuspidor. If the connector is turned the wrong way, it will not go into the port. Use of unnecessary force will break the connector.

NOTE

There are three USB ports on the cuspidor. Make sure you attach the connector to the right port, see section "Cuspidor" on page 26.

NOTE

To avoid splashes on the scanner, remove it from the dental unit after use and place it on the table stand.

For more information, see *Planmeca Emerald/Emerald S & Romexis CAD/CAM user's manual*.

23.12.1 Operating intraoral scanner from foot control

The control panel guides you how to operate the intraoral scanner from the foot control.

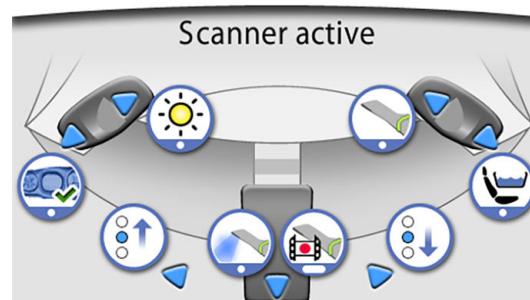
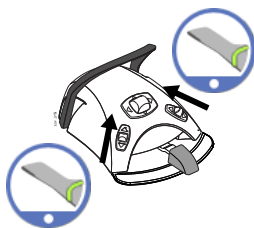
**Activating instrument view**

The foot control can be configured so that the Planmeca intraoral scanner is activated when you first pick up the scanner from the Flexy holder and then push the left-side or the right-side knob up. Contact your Planmeca dealer.

The scanner can be deactivated by pushing the knob up once more.

Generating model

Push the left-side knob down to generate a model of the scanned area.

Selecting scanning mode

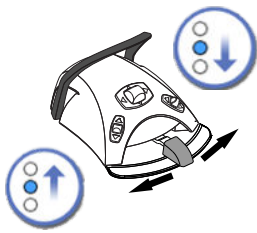

To move upward in the list of scan type selection tools in the Planmeca Romexis menu on the monitor, push the foot control pedal to the left.

To move downward in the list of scan type selection tools in the Planmeca Romexis menu on the monitor, push the foot control pedal to the right.

Starting scanning

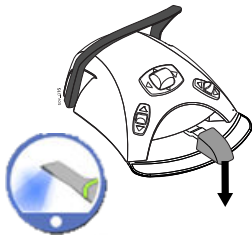

Briefly push the foot control pedal down to start the scanning.

Taking image

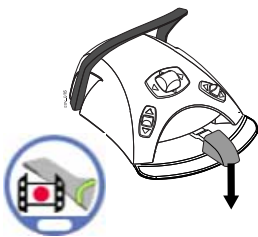

Push and hold down the foot control pedal to take an image.

24 Operating suction handpieces

NOTE

Remove the suction handpiece from the patient's mouth before stopping the suction.

NOTE

In addition to the instructions below, the suction can also be configured so that it is started/stopped by pushing the foot control's left-side or right-side knob up, or by pressing the Flexy button. Contact your Planmeca dealer.



NOTE

If you have stopped the suction from the foot control or the Flexy button while the suction handpiece was in your hand, the suction will start for a while when you return the handpiece to the suction holder. The duration of this post-suction delay is configurable, contact your Planmeca dealer. This feature is not available for the tilting high-volume suction handpiece.

24.1 Saliva and high-volume suction

When a saliva or high-volume suction handpiece is lifted from its holder, the suction will automatically start. When the handpieces are returned, the suction will stop.

When you are using the suction handpiece, the suction can be controlled by sliding the adjuster up or down.

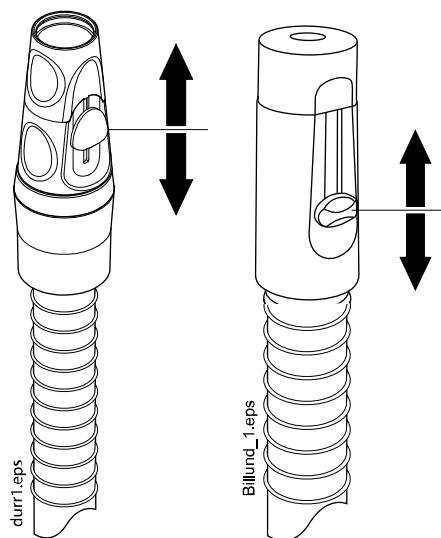

24.2 Tilting high-volume suction

When you lift the suction handpiece from its holder, the weight of the suction tube will cause the end of the handpiece to “tilt” slightly. This action opens the handpiece valve allowing the suction to start.

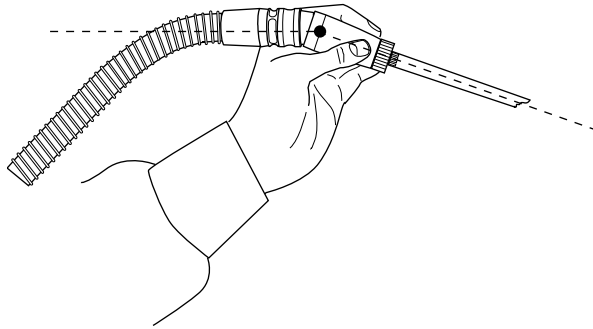

You can stop the suction temporarily by “straightening” the suction handpiece with your thumb and forefinger.

If you temporarily put the suction handpiece down during dental treatment, the suction will automatically stop as the force of the suction will straighten the handpiece.

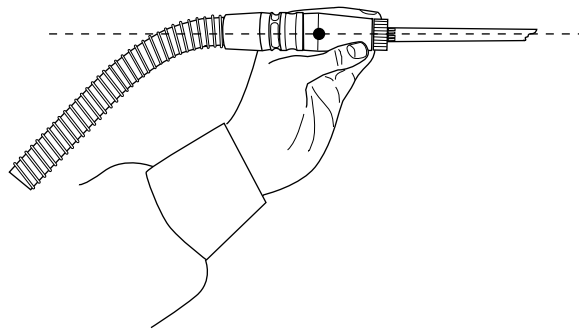

25 Programming

25.1 Introduction

Automatic chair positions, operating light and instrument settings are saved to the user's personal settings. Before you start programming, make sure that you have signed in to the dental unit with your own user name.

NOTE

If the instrument is operated during programming, the changes in settings are seen immediately.

NOTE

The air/water flow of the syringe can not be programmed.

NOTE

To check a function setting (other than automatic position) without programming it, press **Program** and the button of the desired function. The setting is displayed on the control panel. Press **OK** to close the window without changing the setting.

Most of the programming follows the same pattern:

1. If you are programming an instrument, pick up the instrument from the instrument console.
2. Press **Program** to activate the programming mode.
The button turns blue.
3. Select the desired function from the control panel.
4. A pop-up window opens where you can adjust the values with the **plus (+)** and **minus (-)** buttons.



NOTE

Alternatively, you can change the settings with the foot control. To increase the parameter value, push the pedal to the right. To decrease the parameter value, push the pedal to the left. When the pedal is pushed halfway (right or left) the parameter changes slowly. When the pedal is pushed to its extreme position (right or left) the parameter changes quickly.

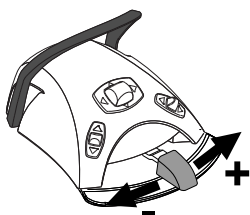

5. Press **OK** to store the new setting into memory.
The pop-up window closes.



When you press **Program**, you will also see the following symbols on the control panel:



service mode



user settings



clock



software update



about this unit

The **Service mode** and **Software update** buttons are reserved for service situations only.

25.2 Organising items on control panel

About this task

You can organise the items in the main window's swipe menu according to your preferences.

Steps



1. Press **Program**.



2. Press **Organise**. A pop-up window opens.

3. Organise the items.

- To move an item, drag the item to the desired position on the menu.
- To remove an item, drag the item to the field at the bottom of the window.
- To add an item, press + and add an item from the selection.
- The swipe menu contains several pages. To move an item to another page, drag the item to the edge of the page and hold it there until the new page opens.



4. Press **OK** to confirm the new order.

If you do not wish to save the new order, press **Close**.

25.3 Automatic chair positions

When you have signed in to the dental unit with your own user name, all changes you make to the automatic chair positions and then save, are saved to your personal settings. This means that whenever you sign in to the dental unit, you will use your last saved automatic chair positions.

NOTE

The chair height cannot be programmed near the upper limit. The help code H 8 is displayed if the chair position is not allowed. When needed, the upper limit can be altered. Contact your Planmeca dealer.

25.3.1 Extended view**About this task****NOTE**

If you only want to rename the automatic position or adjust its position on the list, start programming from step 4.

Steps

1. Move the chair to the required position by using the chair movement buttons on the control panel or by using the foot control.
2. If you want the operating light or its composite mode to be on (off) in this position, turn them on (off).
3. Adjust the intensity of the operating light and/or its composite mode as described in section "Intensity" on page 194.
4. Press **Program**.



5. Press the **Chair positions** button.

A list of automatic positions opens.

6. Select the wanted chair position by pressing it on the list.

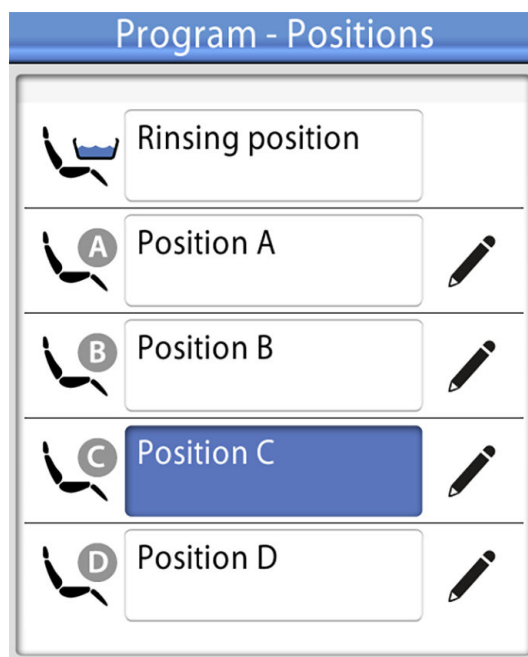

The field of the position that you have selected from the list (position C in picture) turns blue.



- Optionally, edit the name of the automatic position A - D by pressing **Edit** next to the name.

This opens a new window with an alphanumeric keyboard where you can edit the name.

Use the arrows in the top row to move up and down, to the left and right in the text.

The symbols below the arrows in the top row can be used as they are, or as a shortcut to letters containing that symbol. For example, when you press ^ for about one second, letters with the symbol ^ are displayed. You will automatically return to the normal view when you enter one of the letters. To return to the normal view without entering a letter, press the symbol again.

To display special characters, press **Alt**. Press **Alt** again to return to the normal view.

To save the new name, press **OK**. To exit the window without changing the name, press **Close**.



- Press **OK** to confirm that you want to save the current position as an automatic position.

If you do not wish to save the position as an automatic position, press **Close**.

25.3.2 Traditional view

Steps

- Move the chair to the required position by using the chair movement buttons on the control panel or by using the foot control.
For instructions, see section "Manual operation" on page 97.
- If you want the operating light or its composite mode to be on (off) in this position, turn it on (off).
- Adjust the intensity of the operating light and/or its composite mode as described in section "Intensity" on page 194.
- Press **Program**.



- Press the desired chair position where to store the chair's position (rinsing position, A, B, C or D).



- Press **OK** to confirm that you want to save the current position as an automatic position.

If you do not wish to save the position as an automatic position, press **Close**.

25.4 Instrument settings

When you have signed in to the dental unit with your own user name, all changes you make to the instrument settings and then save, are saved to your personal settings. This means that whenever you sign in to the dental unit, you will use your last saved instrument settings.

25.4.1 Instrument speed/power limit

About this task

NOTE

The instrument speed/power limit does not affect the air driven instruments for which quickstart has been selected.

Steps

1. Activate the instrument.
2. Press **Program**.



3. Press **Instrument speed/power limit**.



When you are programming the turbine, press **Turbine speed/power limit**.



A pop-up window opens.

4. For W&H and SycoTec SLM-E Typ 810 brushless micromotors only: Press **%/rpm** to select whether you want to adjust the instrument speed/power limit in percentage points or in rpm. The appearance of the button in the instrument view changes accordingly.



5. Adjust the instrument speed/power limit.

The minimum speed/power limit is 5 or 10% (depending on the instrument) and the maximum is 95%. The adjustment step is 5.

If the preset value is, for example, 50%, the foot control pedal movement controls the speed/power between 5 - 50% instead of the normal range of 5 - 100%.

6. Press **OK**.



The pop-up window closes.

25.4.2 Instrument spray

Steps

1. Activate the instrument.



2. Press **Program**.



3. Press **Instrument spray**.

A pop-up window opens.

4. Adjust the flow rates for water and air.

Scaler: Adjust the flow rates for water 1 and water 2.

The minimum value of all parameters is 0 (no flow) and maximum 100. The adjustment step is 1 in the value range 0 - 35% and 5 in the value range 35 - 100%.



5. Press **OK**.

The pop-up window closes and the new values are displayed on the control panel.

25.4.3 Enabling/disabling sterile water mode

About this task

If the dental unit is equipped with the Planmeca Sterile water system, enable/disable the sterile water mode as described below.

NOTE

The flow rates for sterile water can not be adjusted by the user.

Steps

1. Activate the instrument.



2. Press **Program**.



3. Press **Instrument spray**.

A pop-up window opens.



4. Toggle the **Sterile water** button to enable/disable the sterile water mode.

A grey button means that the sterile water mode is disabled, and a blue button that it is enabled.

NOTE

If you disable the sterile water mode for an instrument that uses sterile water, the flow rate for sterile water 1 and 2 automatically changes to 0%.



5. Press **OK**.

The pop-up window closes.

25.4.4 Automatic chip blow

About this task

NOTE

The type of manual chip blow does not depend on the type of the automatic chip blow, but is dry as a factory default. The manual chip blow can be set to be dependent on programming, contact your Planmeca dealer.

Steps

1. Activate the instrument.
2. Press **Program**.



3. Press **Chip blow**.



A pop-up window opens.

4. Adjust the flow rates for water and air.

The minimum value of both parameters is 0 (no flow) and maximum 100. The adjustment step is 1 in the value range 0 - 35% and 5 in the value range 35 - 100%.

5. Press **OK**.



The pop-up window closes and the new values are displayed on the control panel.

25.4.5 Instrument light

Steps

1. Activate the instrument.
2. Press **Program**.





3. Press **Instrument light**.

A pop-up window opens.

4. Adjust the light intensity.

The minimum value is 70% of the maximum intensity and the maximum 100%, and the adjustment step is 2.

After reaching the minimum value the light is switched off.



5. Press **OK**.

The pop-up window closes and the new values are displayed on the control panel.

25.4.6 Bien-Air MCX and KaVo KL703 LED micromotors

About this task

Changing the instrument spray, chip blow and LED values for the Bien-Air MCX and KaVo KL703 LED micromotors follows the normal programming pattern. For more information, see sections "Instrument spray" on page 178, "Automatic chip blow" on page 180 and "Instrument light" on page 180.

Steps

1. Activate the micromotor.
2. Press **Torque**.



The micromotor's drive mode is automatically set to **Torque control** (Auto stop). This means, that when the torque limit is reached, the micromotor stops. No other drive modes are available for the Bien-Air MCX and KaVo KL703 LED micromotors.

3. Optional: Adjust the micromotor speed rate (RPM).



- 3.a. Press **Program**.



- 3.b. Press **RPM limit**.

A pop-up window opens.

3.c. Adjust the micromotor speed rate (RPM).

Alteration of RPM speed rate in different ranges

Range	In steps of:
100 - 200	10 (e.g. 110, 120 etc...)
200 - 500	20 (e.g. 220, 240, 260 etc...)
500 - 1 000	50 (e.g. 550, 600, 650 etc...)
1 000 - 2 000	100 (e.g. 1 100, 1 200 etc...)
2 000 - 5 000	200 (e.g. 2 200, 2 400 etc....)
5 000 - 10 000	500 (e.g. 5 500, 6 000, 6 500 etc...)
10 000 - 20 000	1 000 (e.g. 11 000, 12 000 etc....)
20 000 - 38 000	2 000 (e.g. 22 000, 24 000 etc....)

3.d. Press **OK**.



The pop-up window closes and the new value is displayed on the control panel.

4. Optional: Adjust the torque limit.

4.a. Press **Program**.



4.b. Press **Torque**.



A pop-up window opens.

4.c. Adjust the torque limit rate.

The adjustment range is 10% - 95%.

4.d. Press **OK**.



The pop-up window closes and the new value is displayed on the control panel.

25.4.7 Bien-Air MX2 Plus and KaVo KL703 LED with endo micromotors

25.4.7.1 Modifying preset values

About this task

CAUTION

Before modifying the torque and RPM functions, please refer to the file manufacturer's instructions concerning torque and RPM value recommendations for the files.

If you want to modify the presets presented in section "Presets" on page 134, you can do so by following the steps below.

Steps

1. Activate the micromotor.
2. Press **Torque**.



3. Select the micromotor's drive mode.

Toggle between the drive modes by pressing the current drive mode -button.

The modes are:



Torque control (Auto stop)

The torque is limited to the set threshold. Once the limit is reached, the rotation stops, while the torque is maintained. Once some load is taken off the motor, the rotation continues.



Auto reverse

When the torque limit is reached the micromotor will operate counter-clockwise.



Auto forward

When the torque limit is reached, the micromotor will operate counter-clockwise (auto reverse) for 2 seconds and then return to clockwise direction.

The length of the counter-clockwise rotation is adjusted in step 13.

4. Optional: Adjust the micromotor speed rate (RPM).
 - 4.a. Press **Program**.



- 4.b. Press **RPM limit**.



A pop-up window opens.

4.c. Adjust the micromotor speed rate (RPM).

Alteration of RPM speed rate in different ranges

Range	In steps of:
100 - 200	10 (e.g. 110, 120 etc...)
200 - 500	20 (e.g. 220, 240, 260 etc...)
500 - 1 000	50 (e.g. 550, 600, 650 etc...)
1 000 - 2 000	100 (e.g. 1 100, 1 200 etc...)
2 000 - 5 000	200 (e.g. 2 200, 2 400 etc....)
5 000 - 10 000	500 (e.g. 5 500, 6 000, 6 500 etc...)
10 000 - 20 000	1 000 (e.g. 11 000, 12 000 etc....)
20 000 - 38 000	2 000 (e.g. 22 000, 24 000 etc....)

4.d. Press **OK**.



The pop-up window closes and the new value is displayed on the control panel.

5. Optional: Adjust the torque limit.

5.a. Press **Program**.



5.b. Press **Torque**.



A pop-up window opens.

5.c. Adjust the torque limit rate.

The adjustment range is 10% - 95%.

5.d. Press **OK**.



The pop-up window closes and the new value is displayed on the control panel.

6. Optional: Adjust the counter-clockwise rotation time of the micromotor in the Auto forward mode.

6.a. Press **Program**.



6.b. Press **Auto forward**.



A pop-up window opens.

- 6.c. Adjust the Auto forward time.

The maximum time is 6 seconds and the minimum 0 seconds, and the time can be changed in steps of 0.2 seconds.

- 6.d. Press **OK**.



The pop-up window closes and the new value is displayed on the control panel.

7. Optional: Press **Instrument spray** to toggle between water & air, air and no spray. The amount of water and air can also be programmed.



8. Optional: Press **Chip blow** to switch the automatic chip blow on or off. The amount of water and air can also be programmed.



9. Optional: Press **Instrument light** to switch the instrument light on or off.



Results

NOTE

Changing the instrument spray, chip blow and instrument light values follows the normal programming pattern. For more information, see sections "Instrument spray" on page 178, "Automatic chip blow" on page 180 and "Instrument light" on page 180.

When you have modified the settings of a preset, but have not saved them, a dash (-) replaces the preset number on the control panel.

The procedure for saving the modified preset settings is explained in section "Saving modified preset values" on page 185.

25.4.7.2 Saving modified preset values

About this task

When you have modified the Bien-Air MX2 Plus or KaVo KL703 LED with endo instrument settings, you can store them under any preset so that the modified settings are in use next time you select that preset.

Steps

1. Press **Program**.





2. Press **Preset** to open a list of presets.

3. Press the preset under which you want to store the modified settings.
The preset window is closed. The settings are stored in the dental unit when you return the instrument to its holder.

25.4.8 Bien-Air MX-i micromotor

25.4.8.1 Modifying preset values

About this task

Changing the instrument light values for the Bien-Air MX-i micromotor follows the normal programming pattern. For more information, see section "Instrument light" on page 180.

CAUTION

Before modifying the torque and RPM functions, please refer to the implant manufacturer's instructions concerning torque and RPM value recommendations for the implants.

NOTE

When using the Bien-Air MX-i micromotor the torque and rpm limits are always on and can not be switched off.

Steps

1. Activate the micromotor.
2. Optional: Adjust the torque limit.



- 2.a. Press **Program**.

- 2.b. Press **Torque**.

NOTE

Torque can only be adjusted for presets i4 - i5. Presets i1 - i3 have a fixed torque value of 50 Ncm.



A pop-up window opens.

- 2.c. Adjust the torque limit rate.
The adjustment range is 10 - 70 Ncm in steps of 5.
- 2.d. Press **OK**.



The pop-up window closes and the new value is displayed on the control panel.

3. Optional: Adjust the micromotor speed rate (RPM).

3.a. Press **Program**.



3.b. Press **RPM limit**.



A pop-up window opens.

3.c. Adjust the micromotor speed rate (RPM).

The adjustment range is 100 - 2000 RPM for presets i1 - i3 and 5 - 85 RPM for presets i4 - i5.

Alteration of RPM speed rate in different ranges

Range	In steps of:
5 - 20	1 (e.g. 5, 6, 7 etc...)
22 - 42	2 (e.g. 22, 24, 26 etc...)
45 - 85	5 (e.g. 45, 50, 55 etc...)
100 - 300	10 (e.g. 110, 120, 130 etc...)
320 - 600	20 (e.g. 320, 340, 360 etc...)
650 - 1 000	50 (e.g. 650, 700, 750 etc...)
1 100 - 2 000	100 (e.g. 1 100, 1 200, 1 300 etc...)

3.d. Press **OK**.



The pop-up window closes and the new value is displayed on the control panel.

25.4.8.2 Saving modified preset values

About this task

When you have modified the settings of a Bien-Air MX-i micromotor preset, you can store them under that specific preset so that the modified settings are in use next time you select that preset.

NOTE

If you have signed in to the dental unit with a PlanID card, Planmeca Romexis software version 6.2 or later must be installed to be able to save the modified Bien-Air MX-i settings to your personal settings. If Planmeca Romexis 6.2 is not installed, default preset settings are loaded when you sign in to the dental unit.

Steps

1. Press **Program**.



2. Press **Preset**.



3. Press **OK** to confirm that you want to save the new settings.

If you do not want to save the new settings, press **Cancel**.

The preset window is closed. The settings are stored in the dental unit when you return the instrument to its holder.

25.4.9 Morita TORX micromotor

25.4.9.1 Modifying preset values

About this task

If you want to modify the presets presented in section "Presets" on page 144, you can do so by following the steps below.

Steps

1. Activate the micromotor.
2. **All presets:** Adjust the RPM limit.



- 2.a. Press **Program**.



- 2.b. Press **RPM limit**.

A pop-up window opens.

- 2.c. Set the RPM limit.

In the OTR preset, the possible RPM values are 100, 300 and 500.

- 2.d. Press **OK**.



The pop-up window closes and the new value is displayed on the control panel.



3. **All presets except OTR:** Press **RPM limit** to switch the RPM limit on or off.



4. **Presets a1 - a3, OTR and t1 - t3:** Adjust the torque limit.

4.a. Press **Program**.



4.b. Press **Torque**.

A pop-up window opens.

4.c. Adjust the torque limit value.

The adjustment range depends on the preset and is 0.5 - 5.0 Ncm for presets a1 - a3, 0.2 - 1.0 Ncm for the OTR preset, and 0.5 - 2.5 Ncm for presets t1 - t3.

4.d. Press **OK**.



The pop-up window closes and the new value is displayed on the control panel.



5. **Presets a1 - a3 and t1 - t3 only:** Press **Torque** to switch the torque limit on or off.



6. **All presets except OTR:** Press **Reverse** to switch the reverse rotation on or off.



7. **Presets 1 - 3 and t1 - t3 only:** Press **Instrument spray** to toggle between water & air, air, and no spray. The amount of water and air can also be programmed.



8. **Presets 1 - 3 and t1 - t3 only:** Press **Chip blow** to switch the automatic chip blow on or off. The amount of water and air can also be programmed.



9. **Presets 1 - 3 and t1 - t3 only:** Press **Instrument light** to switch the instrument light on or off.



10. **Presets a1 - a3 and OTR only:** Press **Apical action** to toggle between the apical actions auto stop, auto forward, and no action.

NOTE

The button looks different depending on which apical action is currently in use.



11. **Presets a1 - a3 and OTR only:** Press **Sound** to turn off/on the sound of the apex locator.

This only turns off the sound of the apex locator. It has no effect on the beep signals of the torque function. We recommend that you keep the sound on at all times.

Results

NOTE

Changing the instrument spray, chip blow and instrument light values follows the normal programming pattern. For more information, see sections "Instrument spray" on page 178, "Automatic chip blow" on page 180 and "Instrument light" on page 180.



When you have modified the settings of a preset, but have not saved them, an asterisk can be seen on the **Preset** button.

The procedure for saving the modified preset settings is explained in section "Saving modified preset values" on page 190.

25.4.9.2 Saving modified preset values

About this task

When you have modified the settings of a Morita TORX micromotor preset, you can store them under that specific preset so that the modified settings are in use next time you select that preset.

NOTE

Any changes you make to the OTR preset are saved locally to the dental unit only until you sign out from the dental unit. The next time you sign in to the dental unit, default OTR preset settings are taken into use.

Steps



1. Press **Program**.



2. Press **Preset**.



3. Press **OK** to confirm that you want to save the new settings.

If you do not want to save the new settings, press **Cancel**.

The preset window is closed. The settings are stored in the dental unit when you return the instrument to its holder.

25.4.10 Planmeca Lumion Plus polymerisation light

About this task

NOTE

The duration of the polymerisation cycle can be programmed only for the Planmeca Lumion Plus polymerisation light.

Steps

1. Activate the instrument.
2. Press **Program**.



3. Press **Polymerisation cycle**.



A pop-up window opens.

4. Adjust the length of the polymerisation cycle.

The value range is 5 - 100 seconds. The adjustment step is 5 sec. and the default value is 10 sec.

5. Press **OK**.



The pop-up window closes and the new values are displayed on the control panel.

25.5 Timer settings

About this task

Up to six timer settings can be programmed into the timer memory.

Steps

1. Press **Program**.





2. Press **Timer**.

A pop-up window opens.

3. Press the timer that you want to adjust.

A new pop-up window opens.

4. Adjust the length of the timer.

The minimum value is 5 sec. and the maximum 20 min. The adjustment step is 5 sec.



5. Press **OK**.

The pop-up window closes.

25.6 Bowl rinse and cup fill

25.6.1 Adjusting cup fill and bowl rinse flow rates

The flow rates of the bowl flush and cup fill can be adjusted with the two black knobs located inside the dental unit.

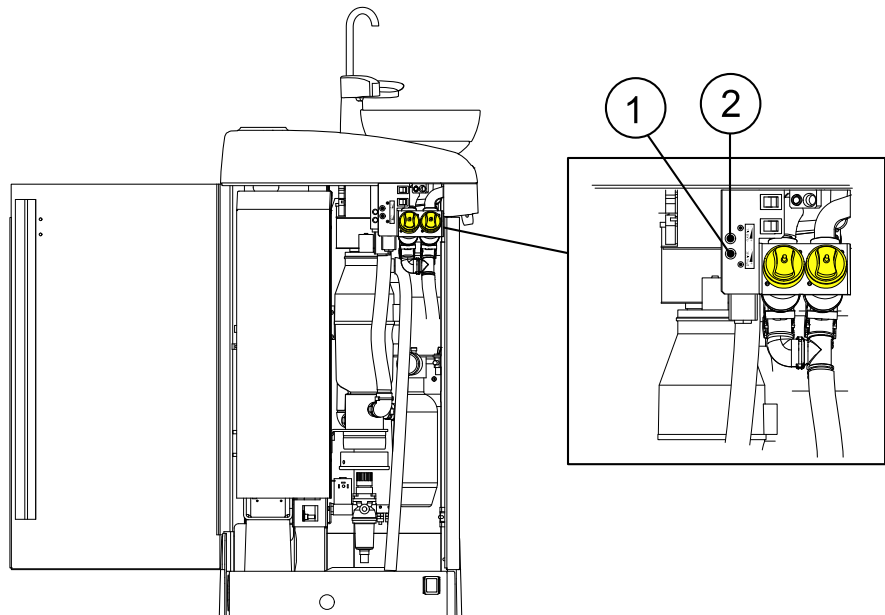

1. Adjustment knob for bowl flush
2. Adjustment knob for cup fill

When you have adjusted the flow rates, you might need to adjust the duration of the bowl rinse and cup fill. For instructions, see sections "Duration of bowl rinsing" on page 193 and "Duration of cup filling" on page 193.

25.6.2 Duration of bowl rinsing

Steps



1. Press **Program**.



2. Press **Bowl rinse**.

A pop-up window opens.

3. Adjust the duration of the bowl rinsing.

The minimum value is 5 seconds and the maximum 240 seconds, and it is adjusted in steps of 5.



4. Press **OK**.

The pop-up window closes.

25.6.3 Duration of cup filling

About this task

NOTE

By default, the cup fill is not activated unless the cup is positioned in its place under the cup fill tube. To change this setting, contact your Planmeca dealer.

NOTE

The water in the dental unit is intended for rinsing only, not for drinking.

Steps



1. Press **Program**.



2. Press **Cup fill**.

A pop-up window opens.

3. Adjust the duration of the cup filling.

The minimum value is 2 seconds and the maximum is 15 seconds. The duration is adjusted in steps of 0.5 seconds.



4. Press **OK**.

The pop-up window closes.

What to do next

The duration of the cup filling can also be programmed as follows:

1. Place an empty cup to the cup holder.
2. Press **Program**.



3. Press **Cup fill**.



4. Push the foot control pedal down. The cup filling time will first be set to 2 seconds and will start to increase after pushing the foot control pedal for 2 seconds. The pedal can be released and then pushed again, and the time continues to increase. Continue until the cup is filled to the desired level.

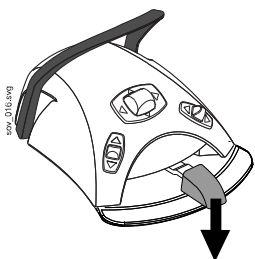

5. Press **Program**.



25.7 Planmeca Solanna and Planmeca Solanna Vision operating lights

25.7.1 Intensity

About this task

NOTE

The light intensity can also be adjusted from the operating light, see sections "Adjusting intensity of operating light" on page 112 and "Adjusting intensity of operating light in composite mode" on page 114.

When you have signed in to the dental unit with your own user name, all changes you make to the light mode settings and then save, are saved to your user profile. This means that whenever you sign in to the dental unit, you will use your last saved light mode settings.

Steps

1. Press **Program**.



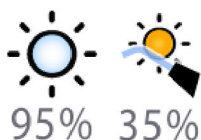

- Press **Operating light** or **Composite mode**. Both buttons open the same pop-up window.

- Open the *Intensity* tab.

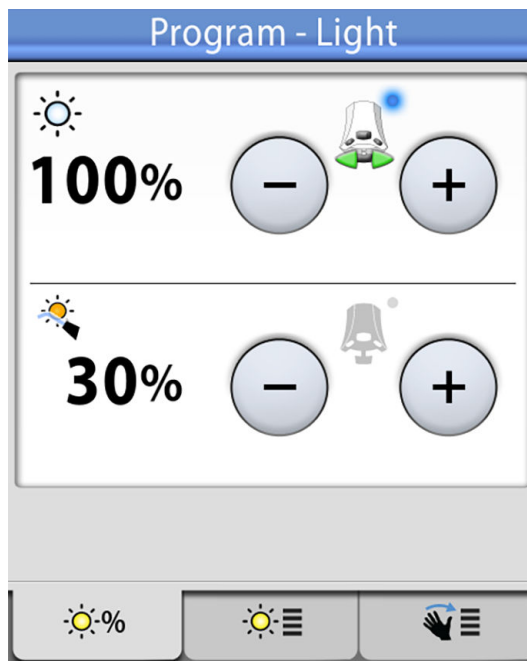

- Adjust the intensity of the operating light or the composite mode.



The active foot control icon shows which value can be adjusted by pushing the foot control pedal to the left or right. To activate the inactive value, press down the foot control pedal or press the **plus (+)** or **minus (-)** button of the inactive value.

The minimum value is 30% of the maximum intensity and the maximum 100%, and the adjustment step is 5.



- Press **OK**.

The pop-up window closes and the new values are displayed on the control panel.

25.7.2 Colour temperature and brightness

About this task

NOTE

The colour temperature can also be adjusted from the operating light, see section "Changing light tone of operating light" on page 115.

Steps



1. Press **Program**.

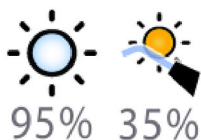

2. Press **Operating light** or **Composite mode**. Both buttons open the same pop-up window.

3. Open the *Colour temperature* tab.



4. Select the white light tone by pressing it. The selected tone is highlighted in blue.
5. Select the maximum brightness by pressing it. The selected brightness is highlighted in blue.
6. Press **OK**.



The pop-up window closes.

25.7.3 Gesture sensor

Steps



1. Press **Program**.

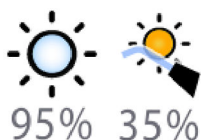

2. Press **Operating light** or **Composite mode**. Both buttons open the same pop-up window.

3. Open the *Sensor* tab.

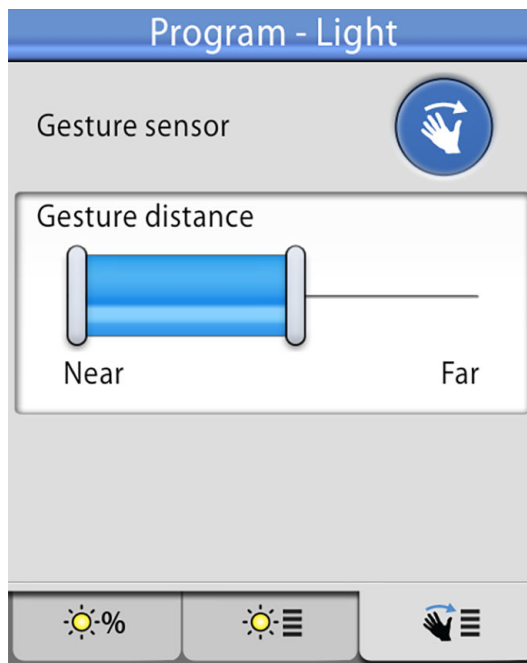

4. Toggle the gesture sensor button to enable/disable the gesture sensor.



A grey button means that the function is disabled, and a blue button that the function is enabled.

5. Adjust the distance at which the gesture sensor on the operating light reads your hand movements by dragging the handles to a suitable position.
6. Press **OK**.



The pop-up window closes.

25.8 Duration of door open / assistant call

Steps



1. Press **Program**.



2. Press **Door open / assistant call**.

A pop-up window opens.

3. Adjust the door open / assistant call time.

The minimum value is 0 seconds, the maximum 250 seconds. The value is adjusted in steps of 1 in value range 0 - 30, and in steps of 5 in value range 30 - 250. The default value is 5.



4. Press **OK**.

The pop-up window closes.

25.9 Clock

About this task

NOTE

If Planmeca Romexis Clinic Management software is used together with this dental unit, you do not need to adjust the clock settings. The dental unit clock is synchronised with the Planmeca Romexis clock every time the dental unit is booted up.

Steps



1. Press **Program**.



2. Press **Clock**.

A pop-up window opens.



3. Select the clock programming view by pressing **Clock** at the bottom of the programming window.



4. Press **12/24** to change the mode (12-hour / 24-hour clock).



5. Adjust the time.

6. Press **OK**.

The pop-up window closes and the new time is displayed on the control panel.

25.10 Date

Steps



1. Press **Program**.



2. Press **Clock**.

A pop-up window opens.



3. Select the date programming view by pressing **Date** at the bottom of the programming window.

When the date is not visible on the control panel, the items in the programming window are grey. This means that they are disabled.

To show the date on the control panel and to enable programming, press the **Date** button at the top of the programming window.

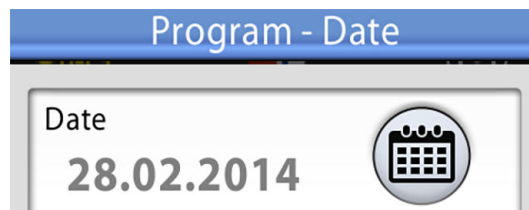

The button will turn blue and all items in the window will turn black (which means that programming is enabled).



4. Select the date format.

Press the arrow to scroll through the different format options:

- dd.mm.yyyy (day, month, year)
- mm.dd.yyyy (month, day, year)
- yyyy.mm.dd (year, month, day)

5. Adjust the day, month and year.



6. Press **OK**.

The pop-up window closes and the new date is displayed on the control panel.

25.11 Wireless foot control

25.11.1 Pairing wireless foot control

About this task

If no wireless foot control is connected to your dental unit, or if you want to change the current wireless foot control to another, you must pair the dental unit and the foot control.

Steps



1. Press **Program**.



2. Press **Foot control**.

The *Wireless foot control* window opens.

3. Open the *Configuration* tab.

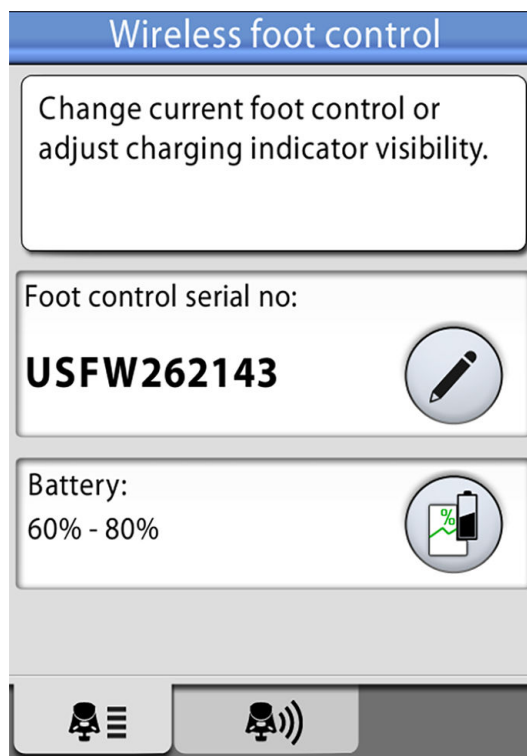

4. The *Foot control serial no* field displays the current foot control's serial number. If you want to change the foot control, press **Edit**.

NOTE

On the foot control, the serial number can be found on its underside.

The *Bind foot control* window opens.

5. Press and hold down the handle of the foot control that you want to pair your dental unit with to select it.

The selected foot control is shown with a black font on the list (marked with arrow in the picture below).

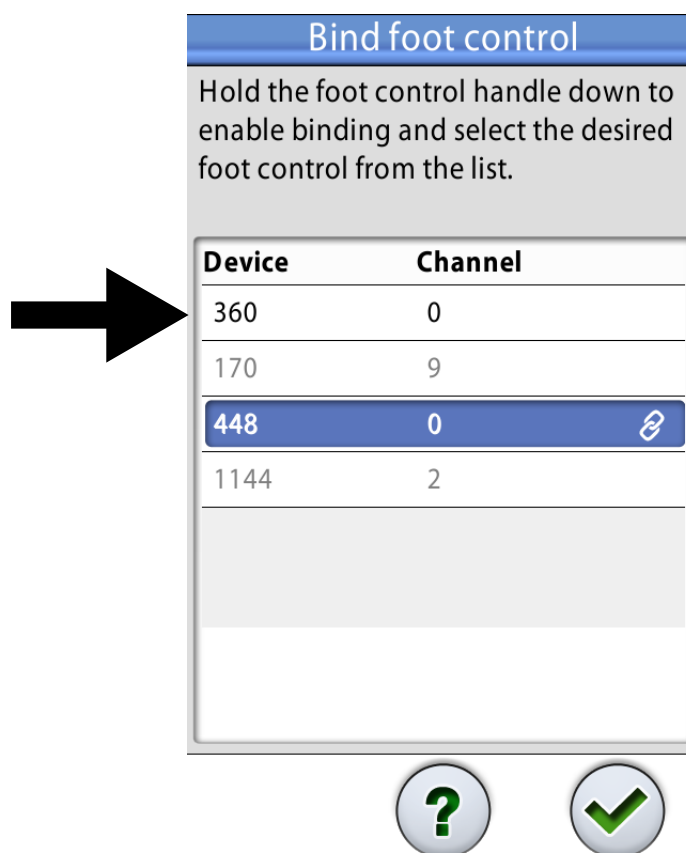

The foot control that is highlighted in blue is the currently paired foot control.

NOTE

For information on the different markings in the *Bind foot control* window, press **Questionmark**.

6. While holding the handle down, start pairing by touching the name of the selected foot control (black font) on the list.

A confirmation message is displayed on the dental unit's control panel.

7. Press **OK** to confirm the start of the pairing process.



8. Release the foot control handle.

Once the pairing is done, a message is displayed on the dental unit's control panel and the paired foot control is highlighted in blue on the list.

If the pairing is not successful, you will receive a notification, after which you can retry to perform the pairing.

9. Press **OK** to close the window.



25.11.2 Viewing battery charging information

Steps



1. Press **Program**.



2. Press **Foot control**.

The *Wireless foot control* window opens.

3. Open the *Configuration* tab.

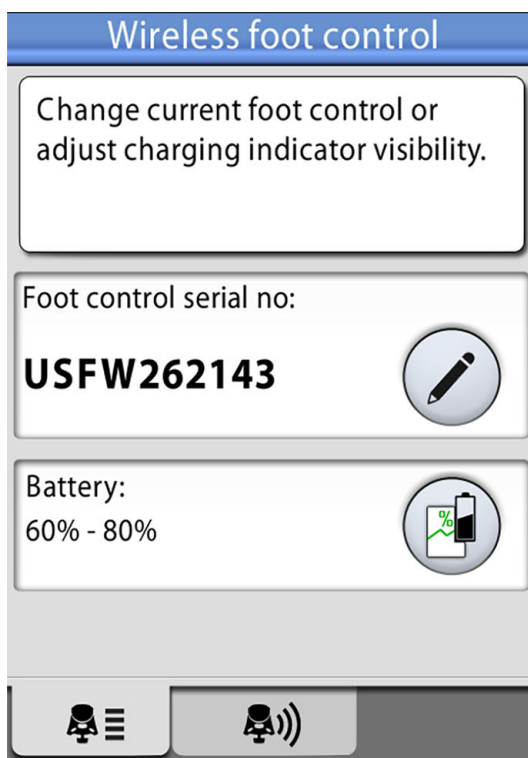

The *Battery* field shows the current charging level of the battery.



4. Press **Battery** to open the battery's charging history log.

If no graph is displayed, press the foot control handle.



5. Press **OK** to close the window.

25.11.3 Adjusting radio settings

About this task

The following describes how to optimise the communication between the dental unit and the wireless foot control.

Steps



1. Press **Program**.



2. Press **Foot control**.

The *Wireless foot control* window opens.

3. Open the *Radio* tab.

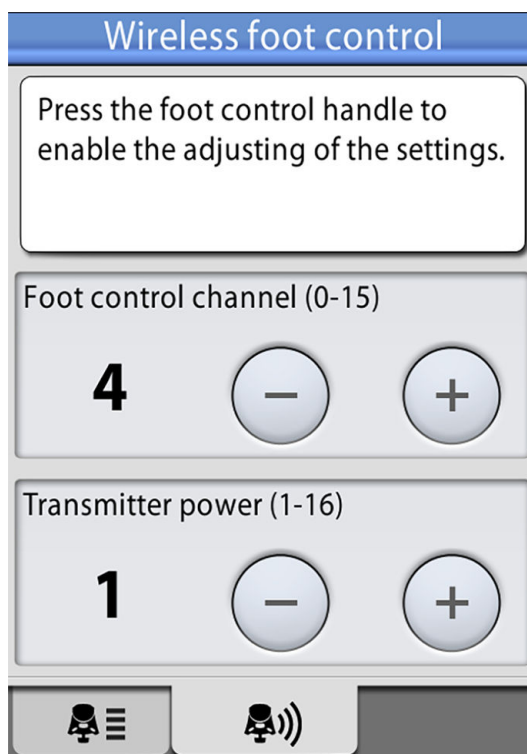

NOTE

If the Foot control channel and Transmitter power fields are inactive, you must press the foot control handle to enable the adjusting of the settings.

4. Select the foot control channel.

You can freely choose between the channels 1 and 16, but, to minimise radio signal interference, no two foot controls within 10 meters of each other should have the same channel.

5. Adjust the transmitter power.

Select the lowest power level and increase it, if needed. The value range is 1 (lowest) to 6 (highest).

6. Press **OK** to confirm your selections and exit the programming mode.



To exit the programming mode without confirming, press **Close**.

26 Calibrating clock

Steps



1. Press **Program**.



2. Press **About this unit**.

3. Select **Service**.

A new window opens.

4. Select **Clock calibration**.

A new window opens.



5. The dental unit asks you to set the current time. Press **Calibrate**.

6. Set the current time by changing the hour, minute and second values with the **plus (+)** and **minus (-)** buttons. It is recommended that you check the current time from an NTP server.



7. Press **OK** to exit the calibration window.

8. Wait for a minimum period of 7 days for the clock to calibrate. However, a calibration period of 2-3 weeks is recommended.



9. Press **Program** to complete the calibration sequence after the minimum calibration period.



10. Press **About this unit**.

11. Select **Service**.

A new window opens.

12. Select **Clock calibration**.

A new window opens.

13. The dental unit informs that it is ready to calibrate. Press **Calibrate**.



If you at this point want to reset the calibration (the clock resumes the time it had before you started the calibration process), press the **Reset** button. You will be asked to confirm the reset in a new window.

14. Adjust the time to match the correct time by changing the hour, minute and second values with the **plus (+)** and **minus (-)** buttons. When you adjust the time, it is recommended that you check the correct time from an NTP server.



15. Press **OK** to close the window.





The calibration can also be reset at this point, if you, for example, notice that an error has been made during the calibration process.

27 Flushing and cleaning programs

27.1 When to use cleaning programs

We recommend that you run the flushing and cleaning programs as follows:

Recommended cleaning intervals

Icon	Cleaning program	When	Duration
	Short flushing	After every patient	30 seconds / instrument (default)
	Long flushing	In the morning and after the working day	2 minutes (default)
	Suction cleaning	After the working day	6 - 8 minutes
	Waterline cleaning	Once a week. We recommend that waterline cleaning be performed once a week after the working day (but not over the weekend).	2 minutes in the evening + min. 8 hours affect time + 5 minutes in the morning

27.2 Before you start

NOTE

Always feed cold water to the dental unit.

NOTE

The water in the dental unit is intended for rinsing only, not for drinking.

NOTE

The water tap must be closed when the dental unit is not in use.

NOTE

If disinfectant is splashed on the surfaces of the dental unit, remove the splashes instantly with water and mild soap to avoid stains.

In the Maintenance mode you can perform instrument flushing as well as cleaning of the suction tubes and the dental unit's waterlines.

The duration of the cleaning procedure depends on the dental unit configuration and the amount of instruments and suction tubes to be cleaned.

When the cleaning procedure of the instruments is running, the status of the procedure is displayed on the control panel.

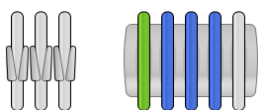

The instrument hose positions on the control panel correspond to their positions on the instrument console. A selected item is displayed in blue, and an item that is being cleaned is displayed in a blinking green. When all items have been cleaned, they are displayed in a steady green. If the cleaning procedure for some reason is interrupted or not successful (for example, there is no water flow), the item is displayed in yellow.



To enter the Maintenance mode, press the **Maintenance** button.

The *Maintenance* window shows the different cleaning programs.

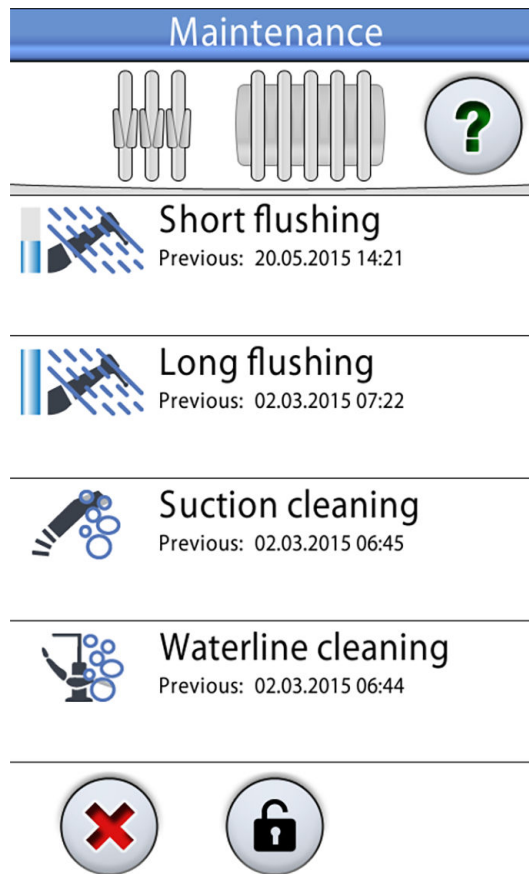

The time stamp under the cleaning program name is an easy way to check when the cleaning program was last started. However, it does not tell whether the cleaning program was successfully completed.

While performing the flushing/cleaning, follow the instructions displayed on the control panel. When the cleaning program runs without problems, the messages only show briefly, but all messages can be viewed in the message history log.





To view the message history log, see section "Viewing help and error message history" on page 257.

Some control panel buttons are common for all cleaning programs, see the following table.

Common cleaning program functions

Button	Function
	Displays additional information about the cleaning program when you press the button during the cleaning cycle.

Common cleaning program functions

Button	Function
	Closes the pop-up window.
	Minimises the pop-up window.
	Cancels the selected action.
	Indicates that the touch display is unlocked. Press to lock. Useful, for example, when cleaning the touch display or when using a table-top instrument.
	Indicates that the touch display is locked. Press for 1 second to unlock. A progress bar is displayed while you press.

NOTE



Alternatively, the dental unit can be configured so that the touch display is locked/unlocked when you press the Flexy button. Contact your Planmeca dealer.

Placing syringe in flushing holder

Each type of syringe has its dedicated place in the flushing holder. The picture below shows the syringe openings in the holder, but note that the picture is an example only and does not represent the actual holder.

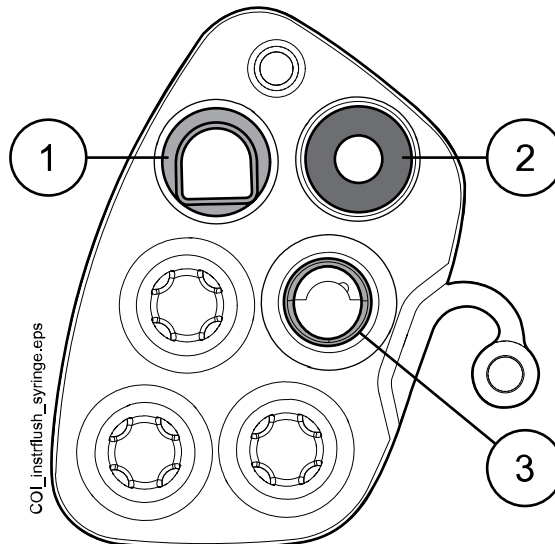

1 Luzzani Ergo syringe

Remove the metallic syringe cover and place the syringe in the flushing holder. Make sure you insert the syringe the right way so that it fits into the holder.

2 DCI syringe

Remove the syringe cover and place the syringe in the flushing holder. Lock the syringe into place with a rotating movement when the syringe is in the holder.

3 Luzzani Minibright syringe

Remove the metallic syringe cover and place the syringe in the flushing holder. Lock the syringe into place by pushing it downwards until you hear a click.

27.3 Short instrument flushing

About this task

NOTE

The duration of the short flushing cycle is configurable. Contact your Planmeca dealer.

NOTE

You can interrupt the flushing cycle by pressing **Close**. After the interruption, the dental unit can be used normally.



Steps



1. Press **Maintenance** to go into maintenance mode.
2. Remove the cup from the cup holder. Turn the bowl away from above the flushing holder as shown in the figure. Turn also the cup fill tube

above the bowl as shown in the figure. Press the outer edge of the flushing holder cover (1) and remove the cover.

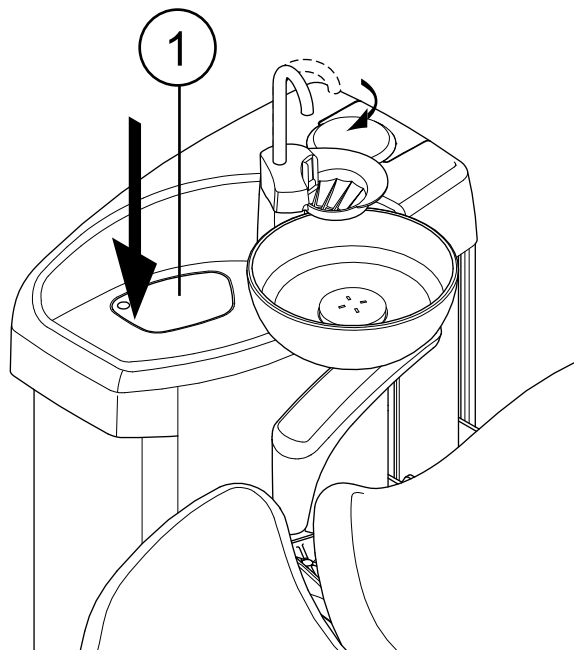

3. Remove the instrument handpieces from the instruments and clean them according to the manufacturer's instructions.
4. Place all water consuming instruments (including syringes) into the openings in the instrument flushing holder.

Optionally, in dental units with balanced instrument arms, you can remove the hoses of the instruments to be flushed from the instrument arms / instrument holders before placing the instruments in the flushing holder.

In dental units with hanging-tube instruments, the instruments to be flushed must be removed from the instrument holders before placing them in the flushing holder.

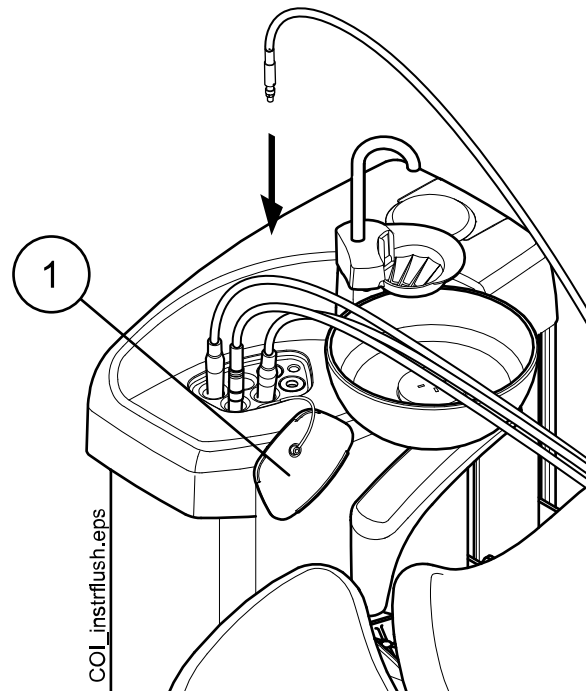

1 Flushing holder cover

5. Start the short flushing cycle.

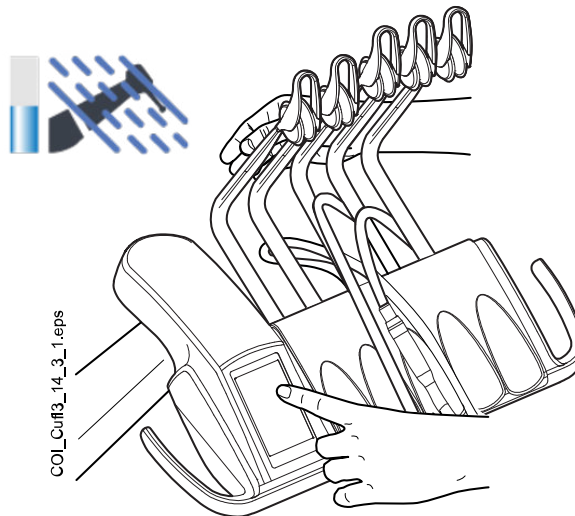

Balanced instrument arms: Start the flushing cycle by bending the instrument arms of those instruments (including syringe) that are to be flushed to an angle of at least 90° and simultaneously selecting **Short flushing** on the control panel.

Hanging-tube instruments: Start the flushing cycle by selecting **Short flushing** on the control panel.

The system will first identify the instruments and then each instrument hose is flushed with air and water for 30 seconds in its turn.

6. Release the instrument arms (if your dental unit is equipped with balanced instrument arms).
7. Once the flushing cycle is finished, H 36 is displayed. Remove the instruments from the flushing holder and return them to the instrument console. Place the flushing holder cover back to its position.

If H 36 is still displayed after returning the instruments, activate the syringe and then return it to the instrument console.

If water flow was not detected for all water consuming instruments, H 36.1 is displayed. Run instruments for a while with spray water to ensure that the flushing of instruments is sufficient.

27.4 Long instrument flushing

About this task

NOTE

The duration of the long flushing cycle is configurable. Contact your Planmeca dealer.

NOTE

In units equipped with a water heater, the long flushing fills the waterlines and water heater with cool water and switches the water heater off. The water heater switches automatically back on the next time instrument water spray is used.

NOTE

You can interrupt the flushing cycle by pressing **Close**. After the interruption, the dental unit can be used normally.



Steps



1. Press **Maintenance** to go into maintenance mode.
2. Remove the cup from the cup holder. Turn the bowl away from above the flushing holder as shown in the figure. Turn also the cup fill tube above the bowl as shown in the figure. Press the outer edge of the flushing holder cover (1) and remove the cover.

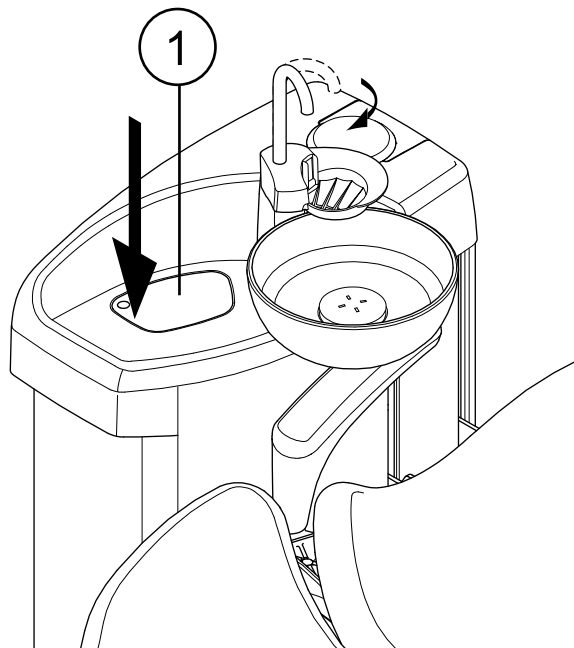

3. Remove the instrument handpieces from the instruments and clean them according to the manufacturer's instructions.
4. Place all water consuming instruments (including syringes) into the openings in the instrument flushing holder.

Optionally, in dental units with balanced instrument arms, you can remove the hoses of the instruments to be flushed from the instrument arms / instrument holders before placing the instruments in the flushing holder.

In dental units with hanging-tube instruments, the instruments to be flushed must be removed from the instrument holders before placing them in the flushing holder.

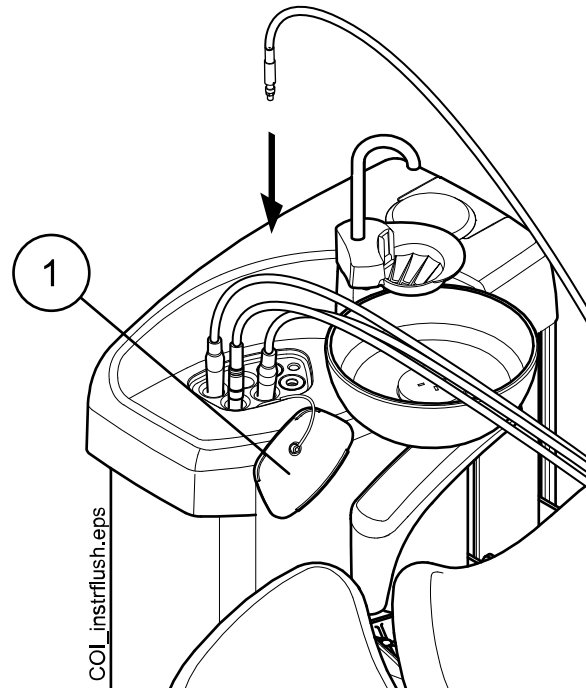

1 Flushing holder cover

5. Start the long flushing cycle.

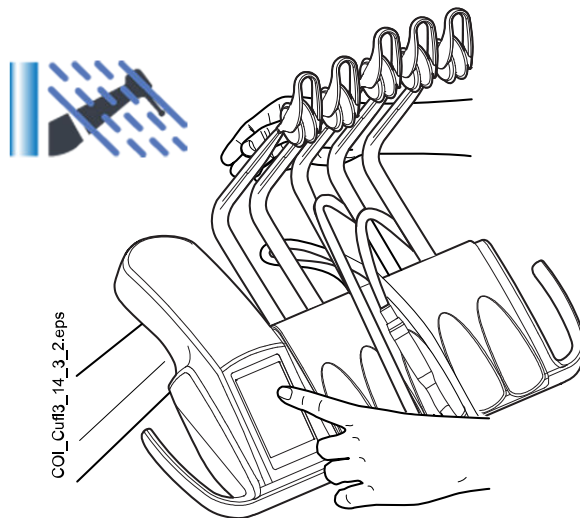

Balanced instrument arms: Start the flushing cycle by bending the instrument arms of those instruments (including syringe) that are to be flushed to an angle of at least 90° and simultaneously selecting **Long flushing** on the control panel.

Hanging-tube instruments: Start the flushing cycle by selecting **Long flushing** on the control panel.

The system will first identify the instruments and then each instrument hose is flushed with air and water in its turn. The time of flushing is the same for all instruments. The total flushing time is displayed on the control panel. At the same time the cup fill tube and the bowl are flushed, too.

NOTE

Adjust the water flow of the cup fill tube so that the water does not splash into the bowl.

6. Release the instrument arms (if your dental unit is equipped with balanced instrument arms).
7. Once the flushing cycle is finished, H 36 is displayed. Remove the instruments from the flushing holder and return them to the instrument console. Place the flushing holder cover back to its position.

If H 36 is still displayed after returning the instruments, activate the syringe and then return it to the instrument console.

If water flow was not detected for all water consuming instruments, H 36.1 is displayed. Run instruments for a while with spray water to ensure that the flushing of instruments is sufficient.

What to do next

NOTE

After the flushing cycle, the unit should immediately be switched off. This procedure ensures that cool water remains in the pipelines of the unit, thus minimising the growth of biofilm.

NOTE

The dental unit can be configured to display help message H 99 if the unit has been switched off without performing long flushing after water has been used. When H 99 has been enabled, it can be displayed as a reminder only, or it can be set to disappear only after you have performed long flushing. To take help message H 99 into use, contact your Planmeca dealer.

27.5 Suction cleaning

About this task

NOTE

The Suction Tube Cleaning System (STCS) is an optional feature. If your dental unit does not have this feature, clean the suction tubes with OroCup as instructed in section "OroCup" on page 241.

Steps

1. Remove the suction handpieces from the suction tubes and clean them according to the manufacturer's instructions.
2. Press **Maintenance** to go into maintenance mode.





- A pop-up window opens.
3. Select **Suction cleaning**.

4. Open the suction cleaning cover.
5. Insert the suction tubes into the suction tube cleaning holder.

NOTE

Make sure that the suction tube cleaning holder itself is in place (i.e. pushed to the bottom of the suction cleaning unit. See step 8 for a picture of the unit).

NOTE

Make sure that a plug is inserted into each empty suction tube holder in the suction tube cleaning holder to prevent the concentrate from spilling.

6. Lift the dosing cubic from the suction cleaning unit and fill it with Planmeca approved suction disinfectant.

The dosing scale indicates the required amount for 1 or 2 suction tubes.

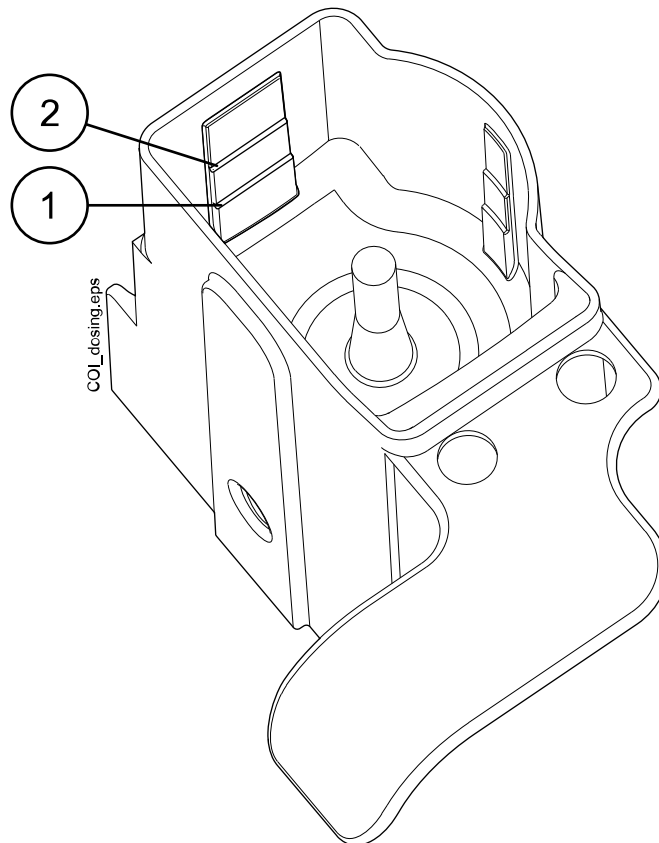

1 One suction tube

2 Two suction tubes

7. Place the dosing cubic back to the suction cleaning unit.
8. The green indicator light of the start button is on when the cleaning program can be started. Start the cleaning by pressing the green start button.

The start button indicator light is flashing during the cleaning procedure and the control panel informs you about the progress of the procedure.

The cleaning program can be interrupted by pressing the yellow cancel button. H 43 is displayed.

After interrupting the cleaning program a final suction is performed automatically. After that you can start the cleaning program again by filling the dosing cubic and pressing the green start button. The program will start from the beginning.

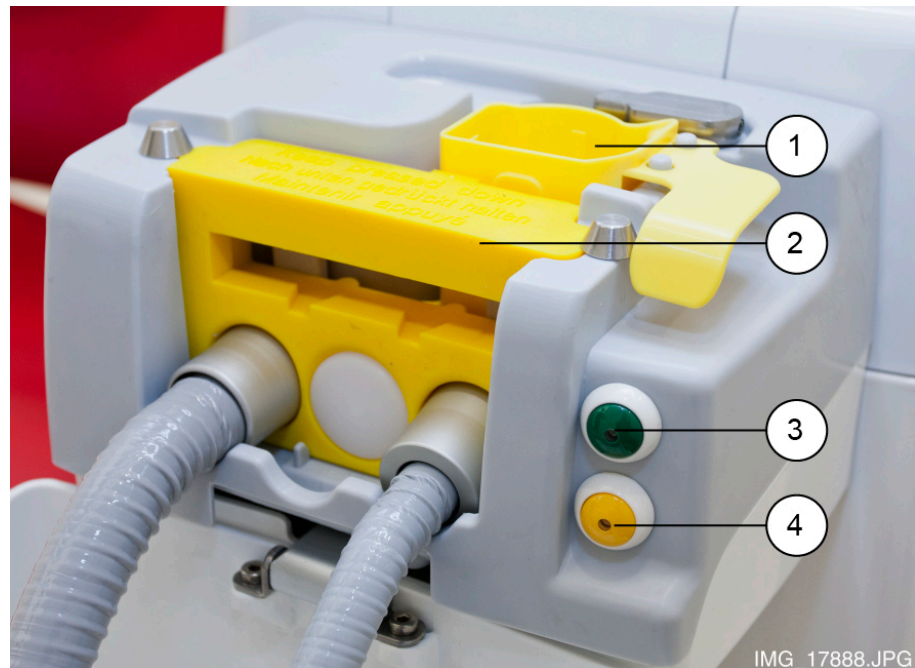

1. Dosing cubic
 2. Suction tube cleaning holder
 3. Start button (green)
 4. Cancel button (yellow)
9. When the cleaning program is completed, help message H 42 is displayed. Return the suction tubes to the suction holder and close the suction cleaning cover.
 10. If suction disinfectant is left in the dosing cubic after the cleaning cycle, clean the cubic under running water.

Results

The dental unit is now ready for normal operation.

NOTE

Before attaching the handpieces back on the suction tubes, wipe the identification bushings (1) with Planmeca approved surface disinfectant.

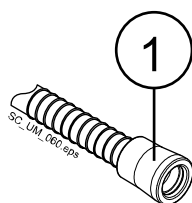

27.6 Waterline cleaning

27.6.1 Introduction

Waterlines are a breeding ground for biofilm. Biofilm may contain bacteria that are harmful to the patient and to the dental team. This is why the waterlines of the dental unit should be cleaned once a week with a disinfectant. The solution is left in the unit overnight and the waterlines of the unit are flushed with water the next morning. The disinfectant should not be left in the waterlines for longer than one night.

After installation, or if the dental unit has not been used for a long time, the waterlines of the dental unit must be treated with a disinfectant for three consecutive cycles.

If you have several dental units with Waterline Cleaning System (WCS), you may use the same container in all of them.



WARNING

Even though every effort has been taken to ensure patient safety, even in case of malfunction or misuse, always make sure that the unit is properly flushed before taking it into use.

CAUTION

Only Planmeca Planosil, Planmeca PlanPure or Alpro Bilpron disinfectant must be used. Planmeca does not guarantee the suitability of and is not liable for damages caused by other disinfectants.

NOTE

If you are using the Clean Water System (CWS), clean the waterlines according to the instructions in section "Waterline cleaning" on page 247.

NOTE

The dental unit waterlines should be cleaned once a week; the Maintenance main window displays when cleaning programs were started. If Planmeca Romexis Clinic Management software is used, detailed information on cleaning cycles can be retrieved. For more information, see the Planmeca Romexis user's manual.

NOTE

Do not let the Waterline Cleaning System run over the weekend.

NOTE

The water must flow properly through the cup fill line, otherwise the unit will not be flushed. Make sure that the cup fill line is not totally closed. The flow through the cup fill line is recommended to be approximately 1 dl / 5 sec.

27.6.2 Starting waterline cleaning cycle

About this task



NOTE

The waterline cleaning program can be cancelled by pressing **Cancel**. If the cleaning cycle is cancelled after the disinfectant container has been attached to the dental unit, flushing is required. Help message H 35 guides you through the flushing.



NOTE

The pop-up windows can be minimised by pressing **Minimise**.

Steps



1. Press **Maintenance** to go into maintenance mode.
2. Remove the cup from the cup holder. Turn the bowl away from above the flushing holder as shown in the figure. Turn also the cup fill tube above the bowl as shown in the figure. Press the outer edge of the flushing holder cover (1) and remove the cover.

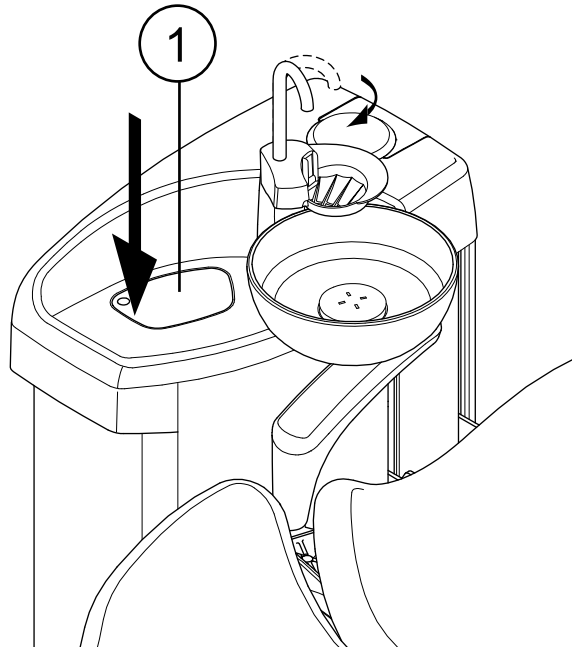

3. Remove the instrument handpieces from the instruments and clean them according to the manufacturer's instructions.
4. Place all water consuming instruments (including syringes) into the openings in the flushing holder.

Optionally, in dental units with balanced instrument arms, you can remove the hoses of the instruments to be flushed from the instrument arms / instrument holders before placing the instruments in the flushing holder.

In dental units with hanging-tube instruments, the instruments to be flushed must be removed from the instrument holders before placing them in the flushing holder.

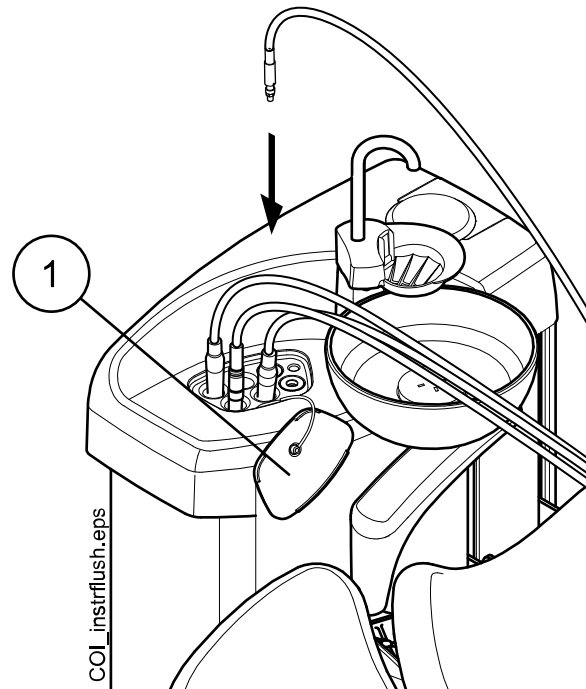

1 Flushing holder cover

5. Start the cleaning cycle.

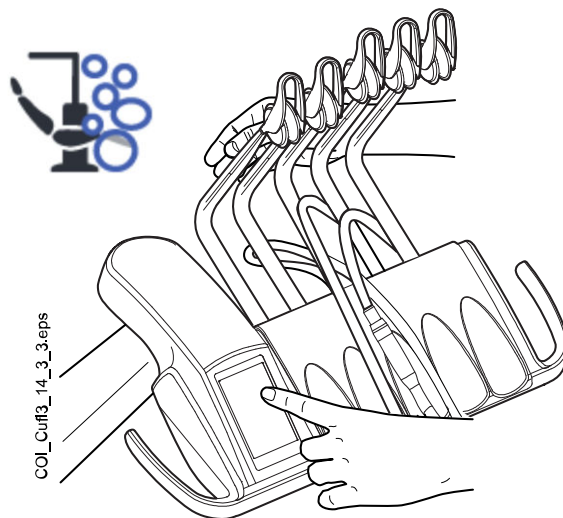

Balanced instrument arms: Start the cleaning cycle by bending the instrument arms of those instruments (including syringe) that are to be cleaned to an angle of at least 90° and simultaneously selecting **Waterline cleaning** on the control panel.

Hanging-tube instruments: Start the cleaning cycle by selecting **Waterline cleaning** on the control panel.

Help message H 30 is displayed.

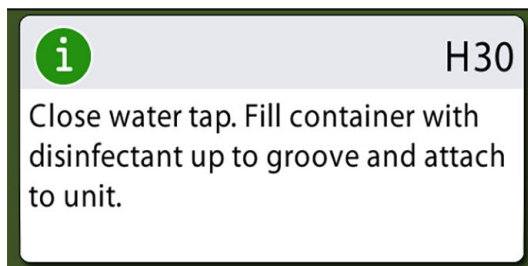

H 30 means that the unit is waiting for the disinfectant container to be attached.

6. Release the instrument arms (if your dental unit is equipped with balanced instrument arms).
7. Close the water tap.

The picture below shows the water tap when it is closed.

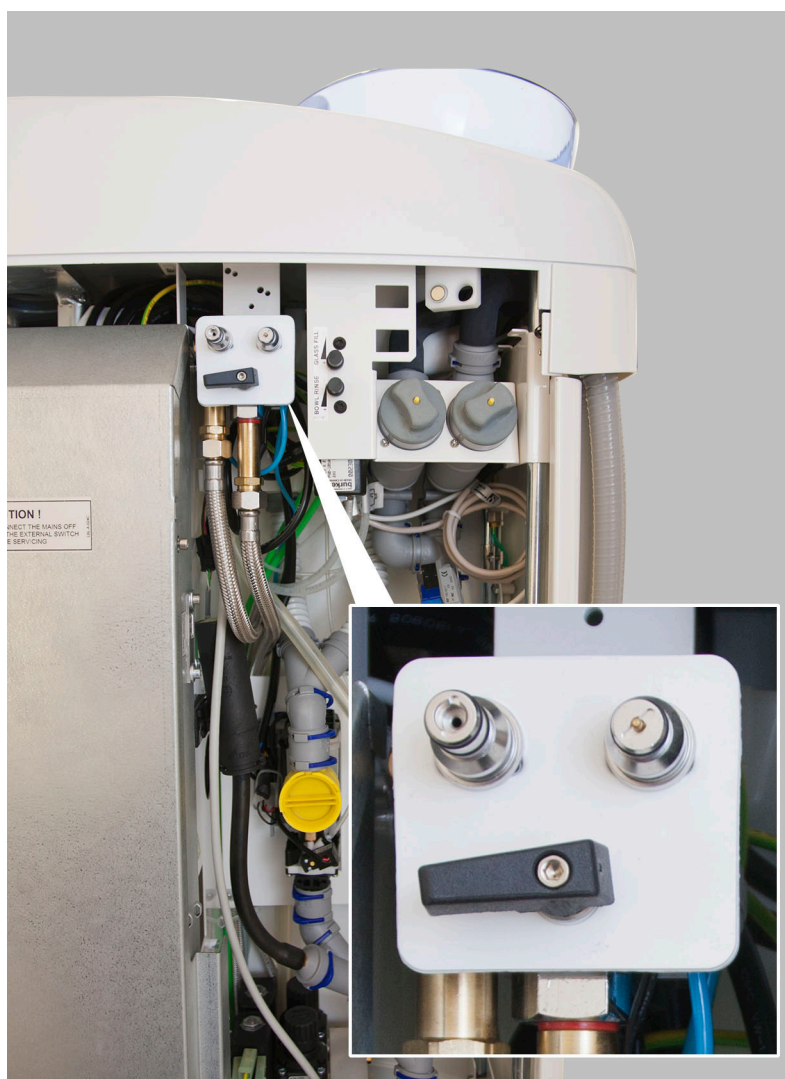

NOTE

The container can not be attached to the unit if the tap is not properly closed.

8. Open the disinfectant container by turning the bottle clockwise so that the locking pin slides along the groove.



9. Fill the container with disinfectant up to the groove (marked with arrow in figure below) and attach the lid. If you need to place the container on the table, place it horizontally.

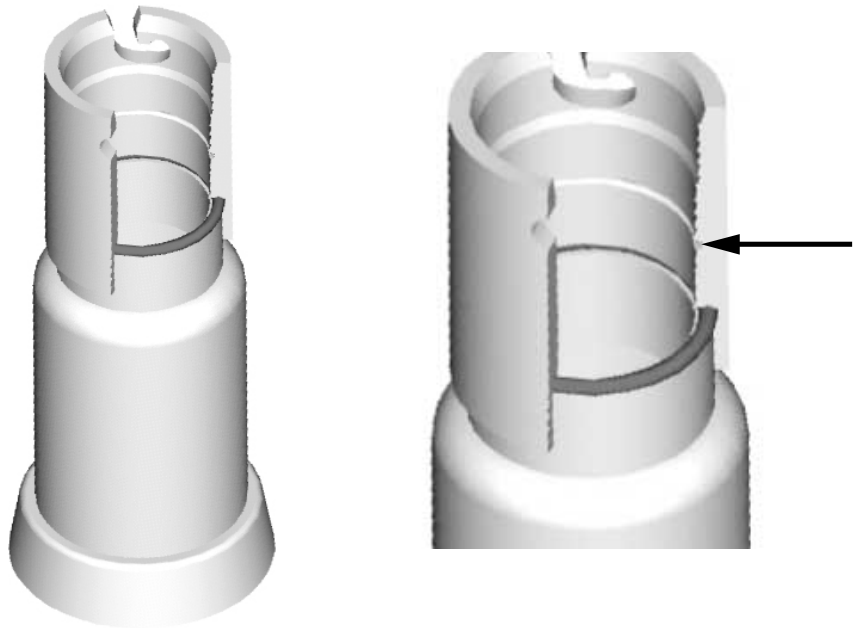

10. Attach the container to the unit.

NOTE

Make sure that the container is properly closed before attaching it to the unit.

NOTE

Do not press the release button (marked with arrow in picture) while attaching the container to the unit.



Automatic feeding begins and the instrument waterlines, the cup fill line and the bowl waterlines are filled. The *Waterline cleaning* window on the control panel informs you about the progress of the cleaning cycle.

Waterline cleaning	
	Cleaning...
Feeding disinfectant	0:28
————— ◯ —————	
Container flushing	0:50
Instrument flushing	4:00

11. When the disinfectant has been fed, help message H 31 is displayed (you will hear a signal tone).

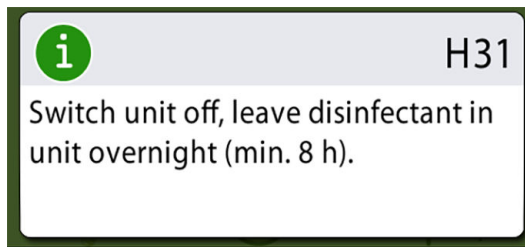

This means that you should now turn off the unit's power.

Let the disinfectant stay in the unit overnight (min 8h). After the waiting period you may proceed to section "Waterline flushing" on page 224.

NOTE

The disinfectant must not be left in the unit for longer than one night (not, for example, over the weekend).

NOTE

If you do not start waterline cleaning as described in this section, but instead start it simply by attaching the disinfectant container to the dental unit, help message H 55 is displayed.

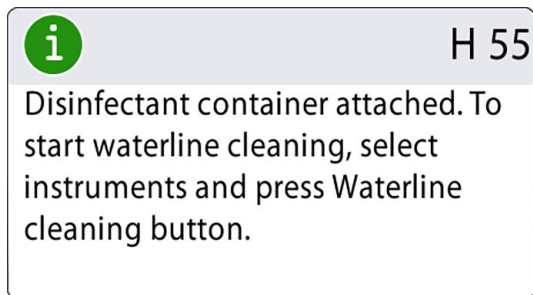

To proceed with the cleaning cycle, you must select the instruments and insert them into the flushing holder as described in steps 1 - 4 in this section and then press the Waterline cleaning button as instructed on the control panel.

To cancel the cleaning cycle, press Close. A help message instructs you how to proceed:

- If the cleaning cycle is cancelled after the container has been attached to the unit, help message H 35.1 is displayed.

- If help message H 35 is displayed, you must open the water tap, select the instruments, put them in the flushing holder and press the Instrument flushing button to flush the instruments.

After flushing, ensure that the water coming from the instruments is clear before you resume working on the dental unit.

27.6.3 Waterline flushing

About this task

When the disinfectant has stayed in the unit overnight, follow the steps below to perform waterline flushing.

Steps

1. Switch the unit on.
Help message H 31.1 is displayed.

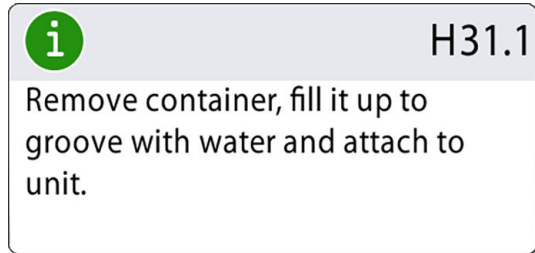

2. Press the release button (marked with arrow in picture) for some seconds to release the pressure and then remove the container.



Help message H 31.2 is displayed.

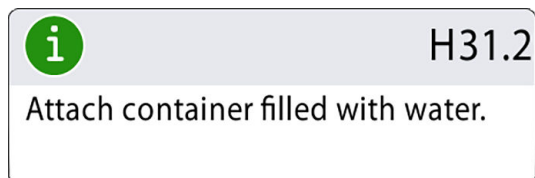

3. Open the lid, rinse the container and fill it with clean water. Attach the lid to the container.
4. Attach the container to the unit.

NOTE

Do not press the release button while attaching the container to the unit.

Container flushing using the water from the container is automatically started through the syringe and cup fill line. The *Waterline cleaning* window on the control panel informs you about the progress of the cleaning cycle.

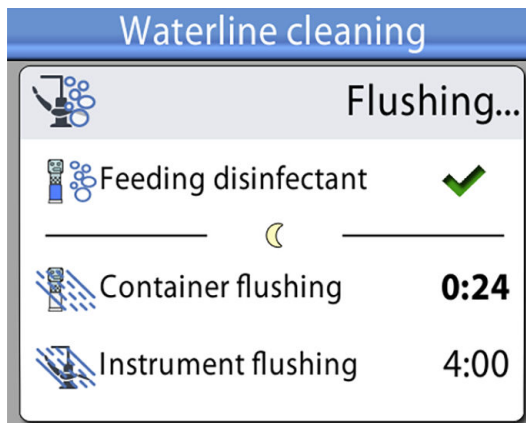

When the container flushing is ready, you will hear a signal tone.

5. Help message H 32 is now displayed.

It means that the pre-rinsing cycle is completed and the container should be removed. Remove possible excess water from the container into the sink. Close the container by attaching the lid. Place the container on a table or in a cabinet to wait for the next use.

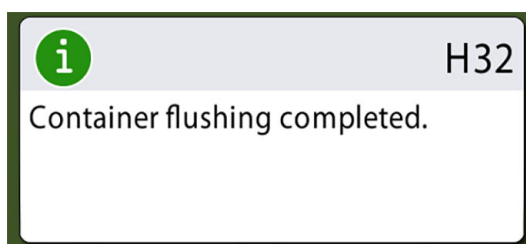

6. Help message H 33 is displayed, meaning that the unit is waiting for the water to be turned on.

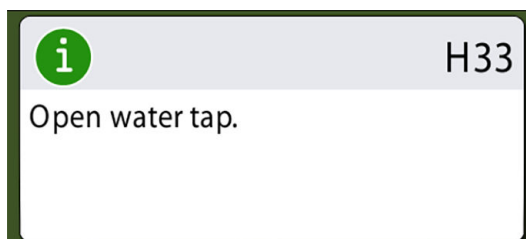

A long instrument flushing cycle using the water from the dental unit waterlines is automatically started after opening the tap. The long flushing takes 4 minutes by default in a dental unit with cup fill and bowl rinse functions.

To extend the duration, contact your Planmeca dealer.

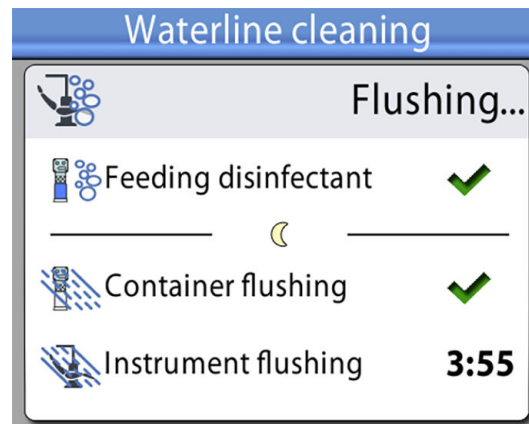

The picture below shows the water tap when it is open.

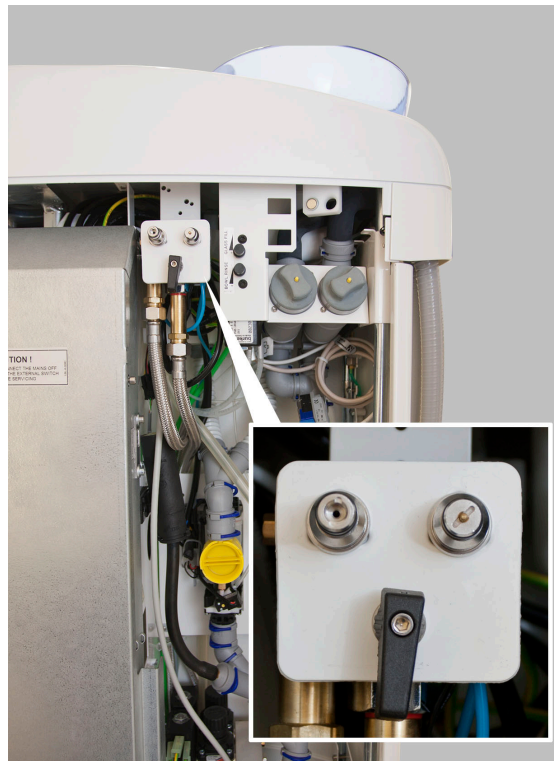

7. After the long flushing cycle, make sure that the water coming from the instruments and cup fill line is clear.

If the water is blue, run water through all water consuming instruments and the cup fill line until the water is clear, and increase the flushing time.

NOTE

To extend the duration, contact your Planmeca dealer.

After this, the unit is ready for normal use.

27.6.4 Maintenance

Change the waterline disinfectant container once a year.

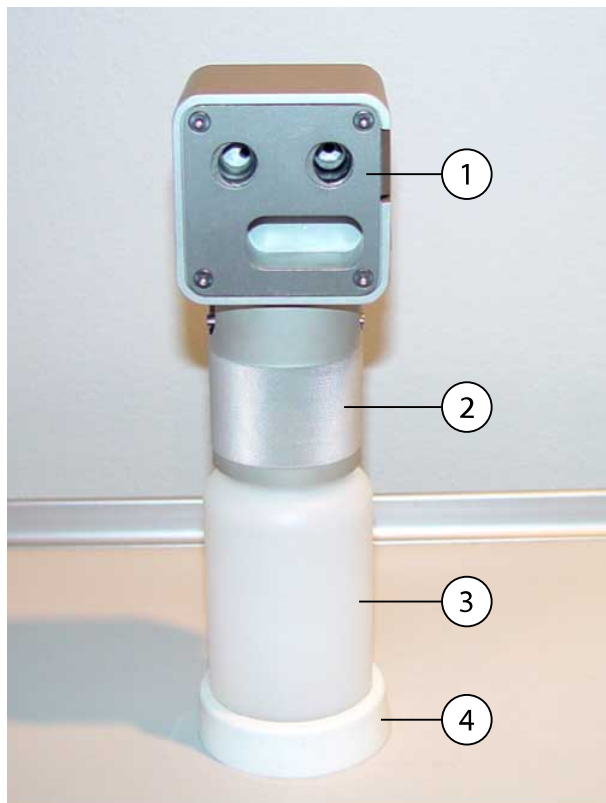

1. Lid
2. Collar
3. Container, code 10040749
4. Standing support

28 Cleaning and disinfection

28.1 Introduction

Planmeca approved surface disinfectants, upholstery disinfectants, dental unit water and waterline disinfectants, and suction disinfectants are listed in the document *Planmeca approved disinfectants* (30007097). The document can be found in the [Planmeca Material bank](#).

NOTE

Do not use cleaning agents in aerosol or spray form directly on any surfaces.

NOTE

All parts must be cleaned before disinfecting or autoclaving them.

NOTE

The washer-disinfector shall comply with the requirements of standard ISO 15883.

NOTE

If disinfectant or cleaning solution is splashed on the surfaces of the dental unit, remove the splashes instantly with water and mild soap to avoid stains.

NOTE

Before starting the cleaning procedures in the evening, hang the foot control on the hook under the patient chair and make sure no cables lie on the floor.



IMG_17897.JPG

28.2 Dental unit surfaces

The table below lists when and how to clean the dental unit surfaces.

Parts and surfaces that are not mentioned in the table can be wiped with a dry cloth.

How to clean dental unit surfaces

When	Part	Cleaning agent	Additional cleaning method		
			Dish-washer (65°C)	Washer-disinfector (93°C)	Autoclave (134°C)
Before working day and after every patient	Instrument console and delivery arm	Planmeca approved surface disinfectant			
	Hygienic membrane	Planmeca approved surface disinfectant			
	Instrument hoses	Planmeca approved surface disinfectant			
	Balanced instrument arms	Planmeca approved surface disinfectant			
	Hanging-tube instrument holders	Planmeca approved surface disinfectant		Monthly	Monthly
	Control panel	Planmeca approved surface disinfectant			
	Trays and tray mats	Planmeca approved surface disinfectant			
	Headrest	Planmeca approved surface disinfectant			
	Armrests	Planmeca approved surface disinfectant			
	Front cover of operating light	Planmeca approved surface disinfectant			
	Handles of operating light	Planmeca approved surface disinfectant		After working day (optional)	After working day (optional)
	Cup fill tube	Planmeca approved surface disinfectant		Weekly	
	Bowl surfaces	Mild soap- and water solution Planmeca approved surface disinfectant	Weekly		
Bowl filter and filter cover cup	Mild soap- and water solution		After working day		

How to clean dental unit surfaces

When	Part	Cleaning agent	Additional cleaning method		
			Dish-washer (65°C)	Washer-disinfector (93°C)	Autoclave (134°C)
	Cuspidor	Planmeca approved surface disinfectant			
	Flexy holder and suction arm	Planmeca approved surface disinfectant			
	On Flexy holder: Suction tube holders, instrument holder, supplementary holders and holder for intraoral scanner	Planmeca approved surface disinfectant		Monthly	
	Suction handpieces	Planmeca approved surface disinfectant		After working day	After working day
	Suction tube reducers	Planmeca approved surface disinfectant			
	Suction tubes	Planmeca approved surface disinfectant			
	Monitor	Planmeca approved surface disinfectant			
	Upholstery	Mild soap- and water solution			
After the working day	Upholstery	Planmeca approved upholstery disinfectant			
	Upholstery foot cover	Planmeca approved surface disinfectant			
	Instrument flushing holder	Planmeca approved surface disinfectant		Monthly	Monthly
	Operating light and monitor arms	Planmeca approved surface disinfectant			
	Foot control	Planmeca approved surface disinfectant			

Parts that should be cleaned weekly

When	Part	Cleaning method
Weekly	Suction tube cleaning holder	Washer-disinfector (93°C). See also section "Suction tube cleaning holder" on page 235.
	Foot control cord	Mild soap- and water solution

NOTE

Once a week, after cleaning, the upholstery should be treated with an upholstery treating agent. Wipe away any excess treating agent after the treatment.

Instrument console

Before cleaning the instrument console, lock the touch display by pressing the **Lock** button in the *Maintenance* window.



When the touch display is locked, the **Lock** button is blue. Press the button for 1 second to unlock the touch display. A progress bar is displayed while you press the button.



Alternatively, the dental unit can be configured so that you can lock/unlock the touch display by pressing the **Flexy** button. Contact your Planmeca dealer.

NOTE

When the dental unit is equipped with hanging-tube instruments, dry the instrument holders properly after cleaning. Wet surfaces might disturb instrument recognition.

NOTE

The instrument console and control panel must be completely dry before covering them with a protective cover.

28.3 Instruments

Clean and service the instruments according to the information supplied with the instrument.

NOTE

After cleaning the instrument, let the oil run from it for at least 10 minutes before replacing it on the console.

Do not use lubricating oil on the Morita TORX micromotor (with the exception of its O-rings).

Throw away the intraoral camera's disposable hygiene sleeve after use.

28.4 Instrument console

28.4.1 Oil collector

Instrument console with balanced instrument arms

The oil collector underneath the instrument console has to be emptied and cleaned monthly. Remove the oil collector by turning it counter-clockwise as shown in the picture below.

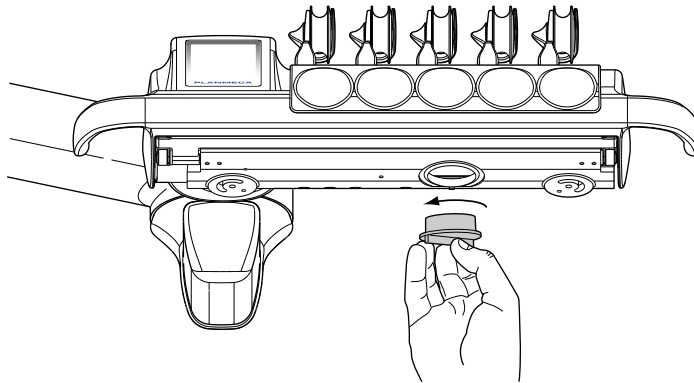

Instrument console with hanging-tube instruments

The oil collector underneath the instrument console has to be checked monthly and emptied when full.

You can check how full the oil collector is without removing it. If the oil level in the narrower chamber has started to fill, it is time to empty the oil collector.

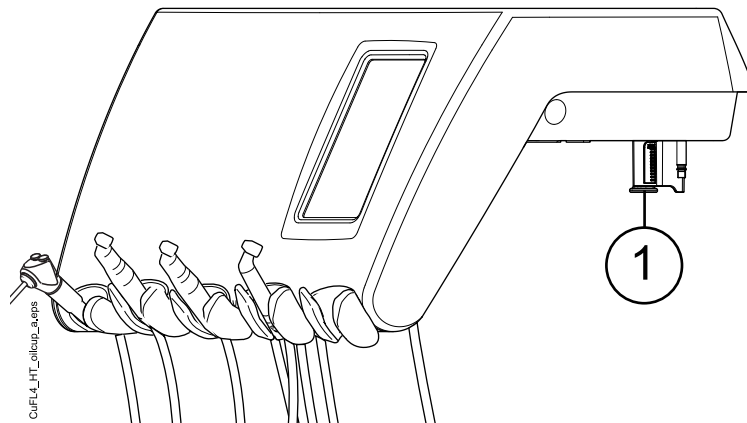

To remove the oil collector from the instrument console, unscrew the oil collector attachment knob and carefully pull the collector out.

28.5 Cuspidor

28.5.1 Bowl

NOTE

Do not pour anything into the bowl unless the unit is switched on and has air and water (that is, the compressor is switched on and the air- and waterlines are opened).

NOTE

Do not pour anything else than water and a suction line cleaning agent into the bowl. The water must be poured slowly into the bowl. The flow may not exceed 5 l/min.

NOTE

Do not empty the bowl filter to the drain!

NOTE

The bowl can be removed and washed in the dishwasher. The maximum washing temperature is 65°C. At higher temperatures the bowl may break. Avoid rapid temperature changes in the dishwasher and when the bowl is in use. When positioning the bowl into the dishwasher, make sure that the bowl does not press other objects in the machine.

Clean the bowl after every patient by pouring a few drops of Planmeca approved suction disinfectant into the bowl and using a soft brush. Rinse the bowl by pressing **Bowl rinse**. The outside of the bowl can be wiped clean with a damp cloth.

The bowl can also be removed and washed in the dishwasher if required. To remove the bowl, do as follows:

1. Turn the bowl and the cup fill tube away from above the cuspidor.
2. Remove the bowl filter parts and empty the bowl filter.
3. Push the bowl fastening clip carefully down and
4. rotate the bowl counter-clockwise.
5. Lift the bowl slightly upward and remove it by pulling it horizontally.

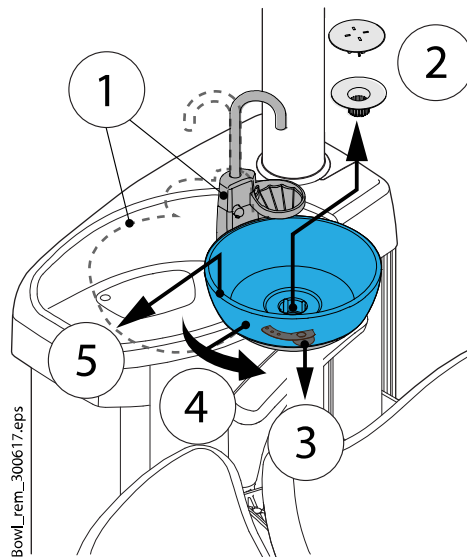

Replace the bowl in reverse order.

NOTE

The cover cap of the filter makes the removal of the filter easier, but the filter can also be used without the cover cap.

28.5.2 Instrument flushing holder

Clean the instrument flushing holder after each working day. Open the flushing holder cover and lift out the instrument flushing holder. Leave the syringe adapter(s) in the flushing holder and disinfect the holder with a Planmeca approved surface disinfectant.

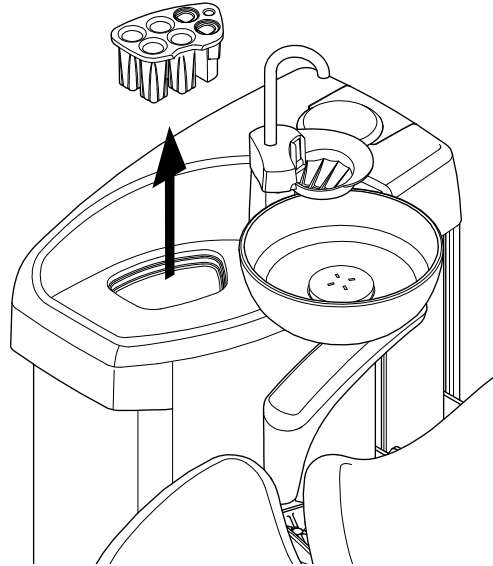

Disinfect the flushing holder once a month in a washer-disinfector at 93°C. After disinfection, it can optionally be autoclaved at 134°C.

Note that the flushing holder cover can not be autoclaved. Remove the cover before autoclaving the instrument flushing holder.

28.5.3 Suction tube cleaning holder

Disinfect the suction tube cleaning holder once a week in a washer-disinfector at 93°C.

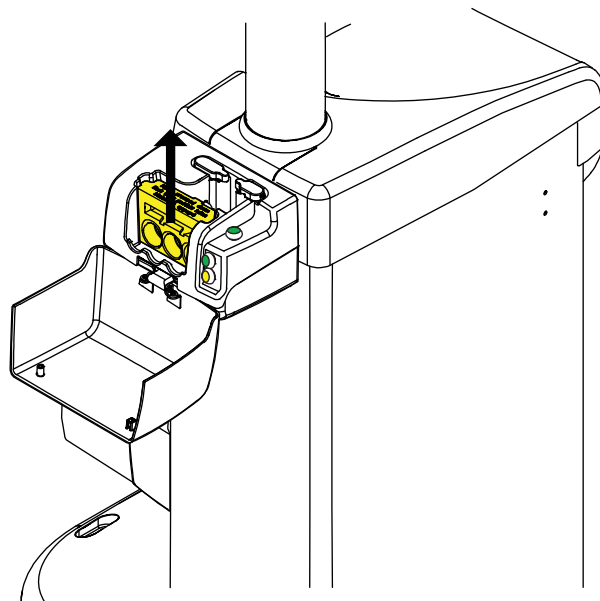

NOTE

When you place the suction tube cleaning holder back in the cuspidor after cleaning, make sure it is pushed firmly into its position in the cuspidor.

28.5.4 Disposable filters

Empty the disposable filters daily or when they are full. Replace them weekly.

NOTE

The disposable filters must be emptied/dispensed into a separate amalgam container.

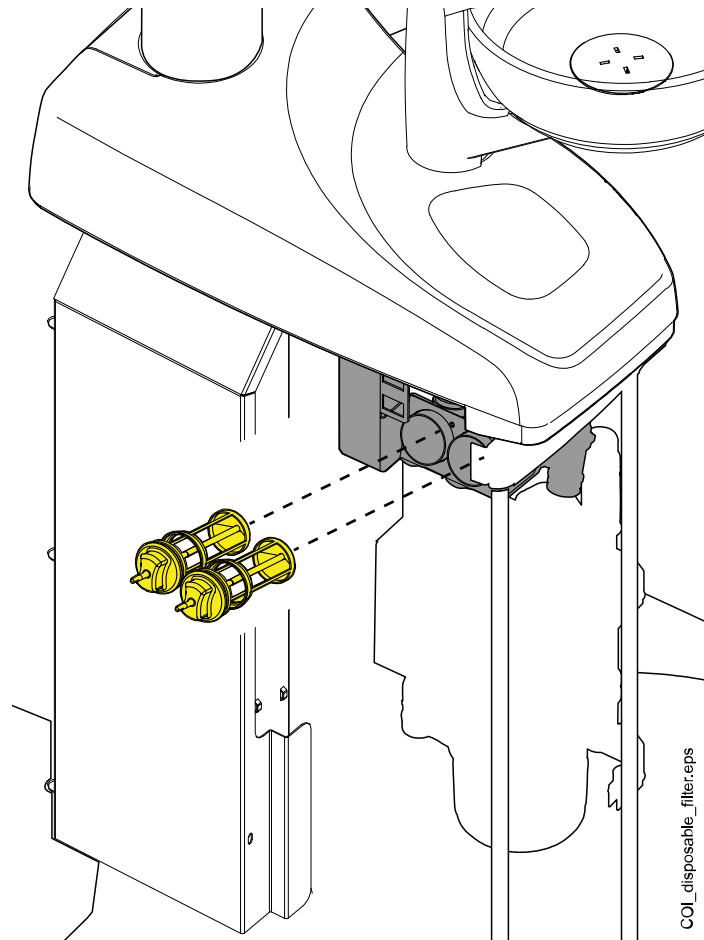

28.5.5 Spittoon valve coarse filter

If your dental unit is equipped with a VS/A compatible suction system, empty the spittoon valve coarse filter when it is full.

NOTE



Before emptying the spittoon valve coarse filter you must empty the bowl (spittoon) valve of any excess water by pressing the Program button for about 5 seconds until the suction starts. The valve will close automatically after about 15 seconds.

NOTE

The spittoon valve coarse filter must be emptied into a separate amalgam container.

When you have emptied the filter, make sure you place it properly back in its holder to prevent the water from leaking onto the floor.

When the filter is clogged, the dental unit will instruct you to empty the filter. In some error situations, the dental unit may also restrict the water flow to prevent leakage.

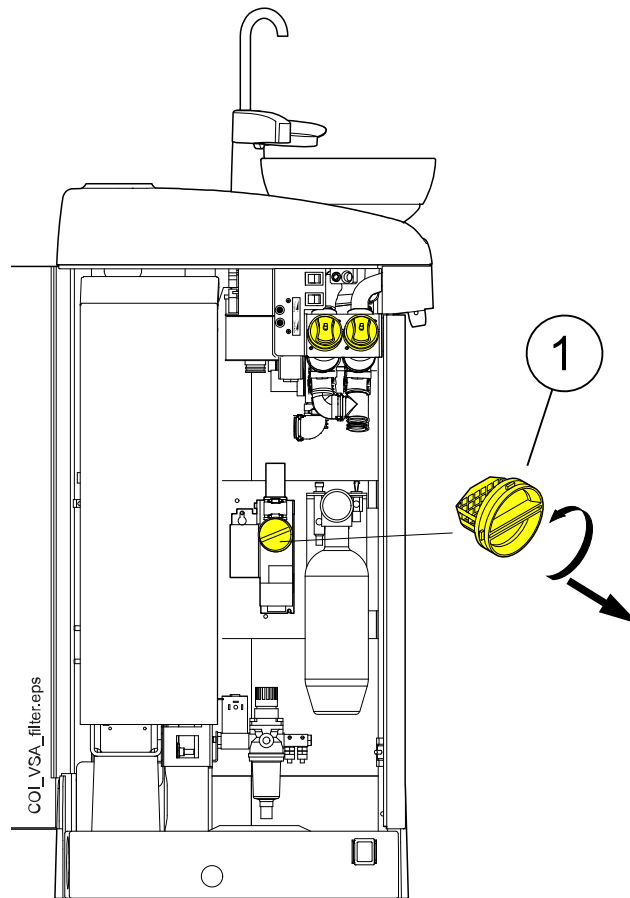

1 Spittoon valve coarse filter

28.5.6 Amalgam collector

CAUTION

Switch the unit off before removing the amalgam collector from the dental unit.

DÜRR CAS1 suction system

Replace the amalgam collector as soon as possible after help message H 1 is displayed, or at least before the next patient.

The degree of fullness of the amalgam collector can also be checked from the indicator light next to the collector on the Dürr CAS1 suction system.

Yellow indicator light	≥ 90 % full
Red indicator light	100 % full

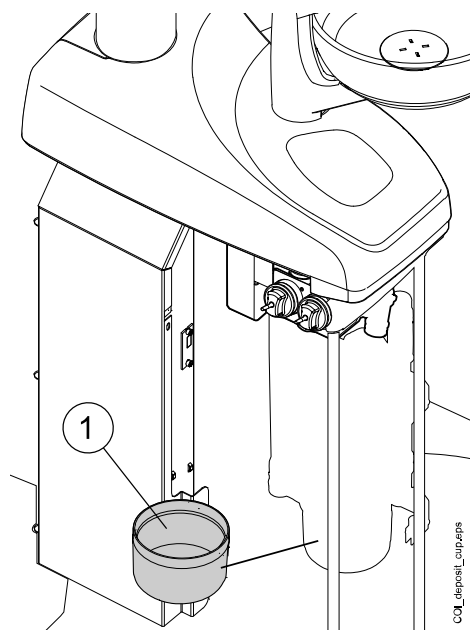

1 Amalgam collector

28.5.7 Deposit cup

CAUTION

Switch the unit off before removing the deposit cup from the dental unit.

DÜRR CS1 suction system

Check the deposit cup weekly and clean or replace it when it is 70% full.
Refer to the instructions supplied with the Dürr separator.

Wet suction system

Check the deposit cup weekly and clean or replace it when it is 70% full.

Microvac suction system

Check the deposit cup weekly and empty and clean it when it is 70% full.

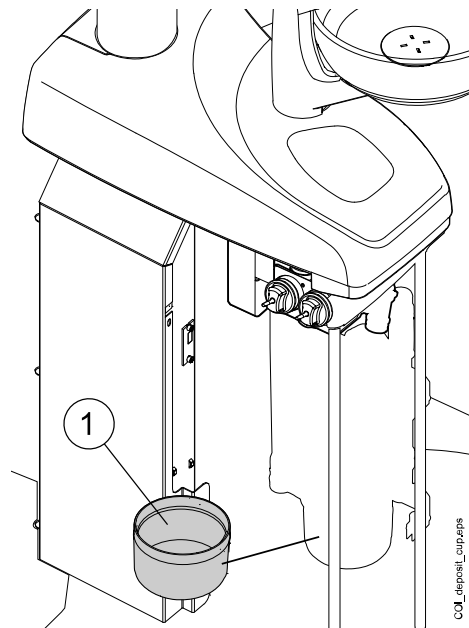

1 Deposit cup

28.5.8 Clean-water bottle

Use a bottle brush and a mild soap- and water solution to clean the clean-water bottle once a week.

To remove the clean-water bottle from the dental unit, first turn the Water bottle switch toward 'OFF'. Then, take a hold of the bottom of the bottle, turn the bottle slightly so that the pin moves along the groove and pull the bottle downwards.

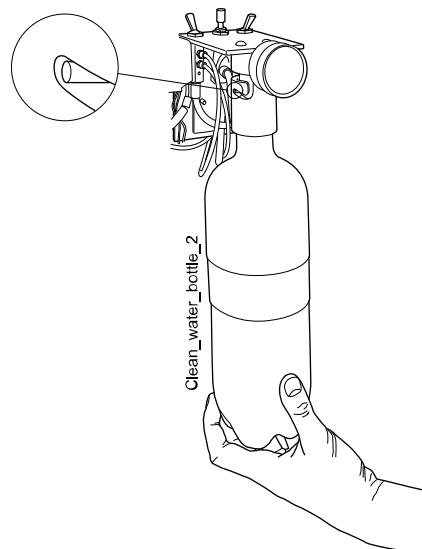

28.6 Suction system

NOTE

Dry the suction tube holders and the tube bushings properly after cleaning. Wet surfaces might disturb suction tube recognition.

28.6.1 In the morning

Steps

1. Rinse each suction tube with 0.5 litres of water by slowly aspirating water and air through the suction handpieces.

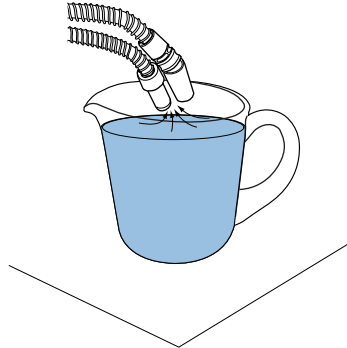

2. Wipe the suction handpieces with Planmeca approved surface disinfectant.

28.6.2 After each patient

Steps

1. Remove the used aspirating tips.
2. For hygienic and operational reasons, empty one glass of water (100 - 200 ml) with each suction tube by aspirating water and air through the suction handpiece. Do this even if only the saliva suction tube has been used.
3. Wipe the suction handpieces with Planmeca approved surface disinfectant.
4. Wipe the suction holder / Flexy holder with Planmeca approved surface disinfectant.

Results

NOTE

Do not use a spray disinfection solution for the suction arms and holders.

28.6.3 After each working day

Steps

1. Disinfect the suction system either by running the suction cleaning program or by using OroCup. For information on the suction cleaning program, see section "Suction cleaning" on page 214.
2. When the suction system has been rinsed, disinfect the suction handpieces in a washer-disinfector at 93°C, then optionally autoclave them at 134°C.

3. Flexy holder: Disinfect the supplementary holders and instrument holder in a washer-disinfector at 93°C.

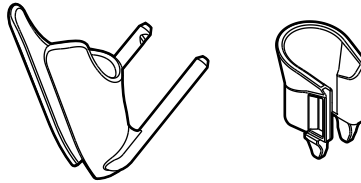

4. Flexy holder: Wipe the holder for the intraoral scanner with Planmeca approved surface disinfectant.

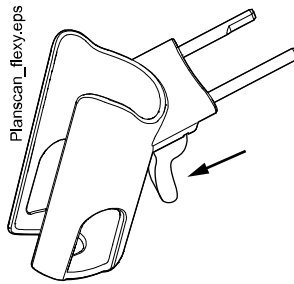

28.6.3.1 OroCup

About this task

The following describes how to disinfect the suction system with OroCup.

Steps

1. Mix the cleaning solution:
Pour 20 ml Planmeca approved suction disinfectant into the rinsing bottle. Add 1 l water and shake well.

NOTE

Do not use dish washing detergents.

2. Place the rinsing bottle (for example OroCup) on a flat surface (table or floor).

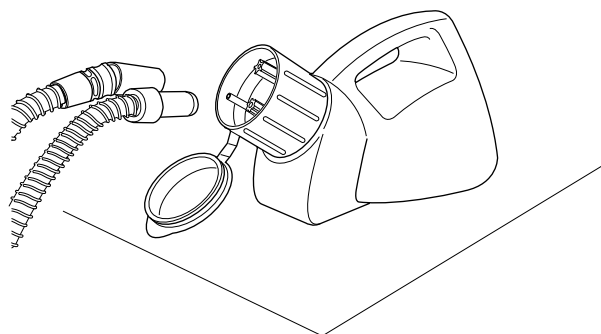

3. Remove the suction handpieces from their holders and push them onto the inserts inside the cap of the rinsing bottle. Allow the bottle to empty.
4. Return the suction tubes back to the holder right after OroCup has been emptied. Do not use suction only for air.
5. Replace the exchangeable parts (filters etc.) the next morning.

28.6.4 Weekly cleaning procedures

28.6.4.1 During working day

About this task

Clean the suction system with Dürr MD 555 cleaner 1 - 2 times a week to prevent the build-up of deposits in the suction system, especially if you are using dental air polishers.

This procedure is mandatory for dental units with a Dürr amalgam separator or Dürr VS/A separator.

For more information on Dürr MD 555 cleaner, please visit <http://www.duerrdental.com>.

Steps

1. Pour 50 ml of Dürr MD 555 cleaner into a rinsing bottle (for example OroCup). Add 1 l water and mix well.
2. Place the rinsing bottle on a flat surface (table or floor).

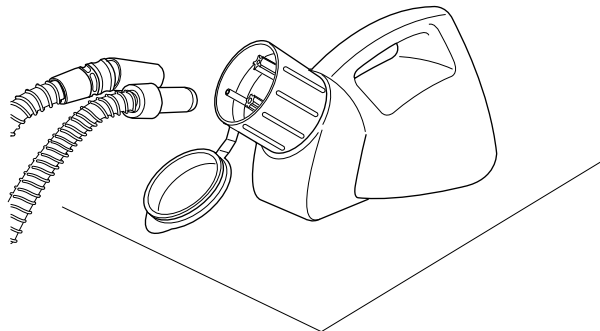

3. Remove the suction handpieces from their holders and push them onto the inserts inside the cap of the rinsing bottle.
4. Remove the suction handpieces from the rinsing bottle when there is 250 ml of the solution left in the bottle.
5. Return the suction handpieces immediately back to the holder. Do not use suction only for air.
6. Open the bowl valve to remove any excess water by pressing the **Program** button for about 5 seconds until the suction starts. The valve will close automatically after about 15 seconds.
7. When the valve has closed, pour the 250 ml that is left of the solution into the bowl.
8. Let the solution affect for 30 - 120 minutes.
9. Rinse the bowl by pressing **Bowl rinse**.



10. Rinse the suction tubes by manually aspirating water through the suction handpieces.

28.6.4.2 After working day

About this task

If your dental unit is equipped with a Dürr amalgam separator or Dürr VS/A separator, you must clean the suction system with Planmeca approved suction disinfectant once a week.

Steps



1. Mix 5 ml of Planmeca approved suction disinfectant with 250 ml water and stir well.
2. Open the bowl valve to remove any excess water by pressing the **Program** button for about 5 seconds until the suction starts. The valve will close automatically after about 15 seconds.
3. When the valve has closed, pour the suction disinfectant solution into the bowl.
4. Let the solution affect overnight. Rinse the suction system the next morning with 2 l of water.
5. Rinse the bowl with water the next morning by pressing **Bowl rinse**.



28.6.5 Cleaning suction handpieces

The following explains how the Dürr and Billund suction handpieces can be disassembled for cleaning. Refer to the manufacturer's instructions for cleaning.

NOTE

We recommend that the suction handpieces be replaced once a year.

High-volume suction handpiece

Pull the handpiece from the suction tube for cleaning, leaving the bushing (1) on the suction tube. The bushing must not be put in a washer-disinfector or autoclave.

If necessary, the handpiece can be completely disassembled for more thorough cleaning. The handpiece parts can be disinfected in a washer-disinfector at 93°C, then optionally autoclaved at 134°C.

Suction tube reducers are used with some high-volume suction handpieces. These can be cleaned in the same way as the handpiece.

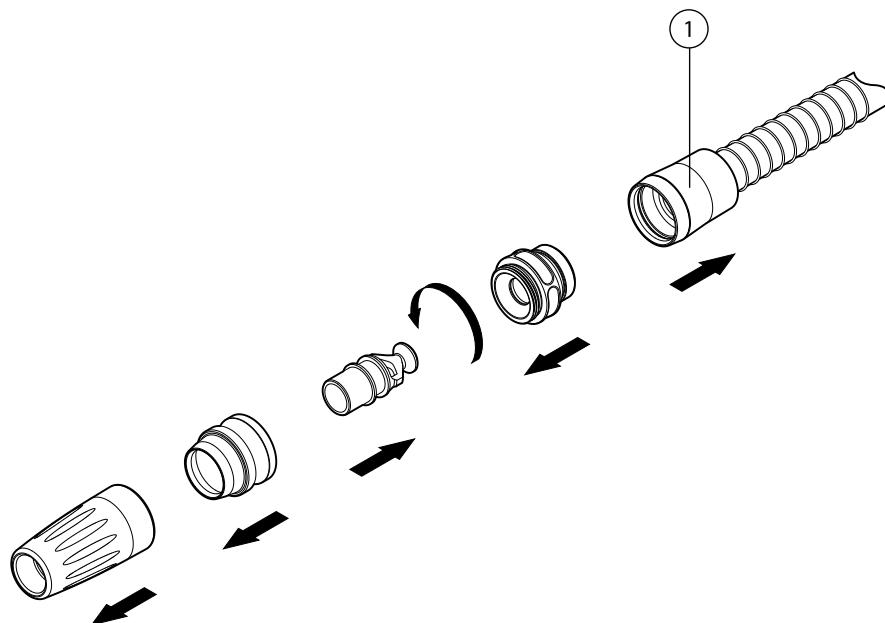

Saliva suction handpiece

The saliva suction handpiece can be disassembled for cleaning by pulling out the end of the handpiece and removing the core (2) and the adjuster (1). The bushing (3) must be left on the suction tube.

The handpiece parts can be disinfected in a washer-disinfector at 93°C, then optionally autoclaved at 134°C. The bushing must not be put in a washer-disinfector or autoclave.

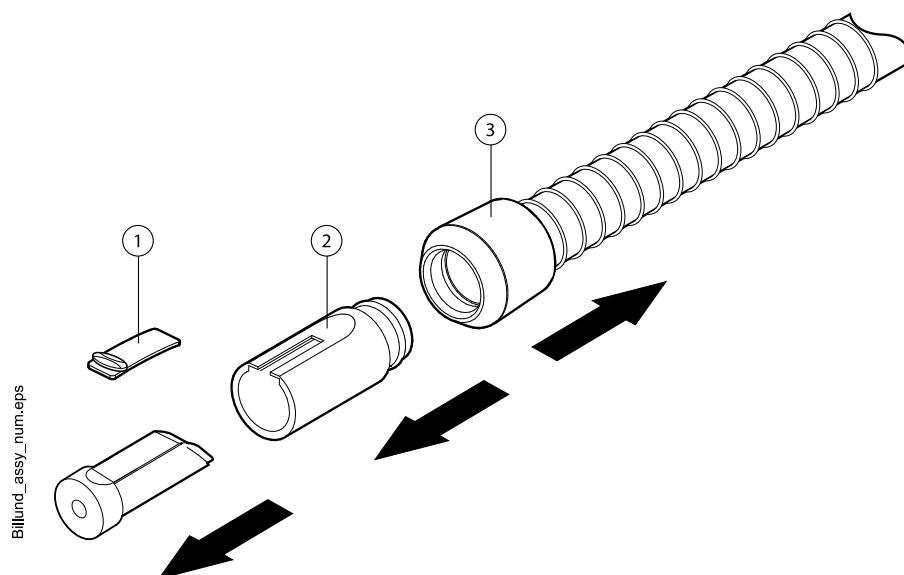

28.7 Planmeca ProX

For information on how to clean the Planmeca ProX X-ray unit, see *Planmeca ProX user's manual*.

28.8 Planmeca ProSensor

For information on how to clean the Planmeca ProSensor sensor, see *Planmeca ProSensor user's manual*.

28.9 Planmeca intraoral scanner

For information on how to clean the Planmeca intraoral scanner, see *Planmeca FIT user's manual*.

28.10 Cleaning external PC

The external PC together with its mouse and keyboard can be wiped with a dry cloth, or according to the manufacturer's instructions.

CAUTION

When cleaning the external PC, always disconnect the PC from the mains electricity supply.

29 Clean water system

29.1 Introduction

In the Clean Water System (CWS), the water that is used for the instruments comes from a clean-water bottle installed to the dental unit. CWS can be used, for example, when the domestic water is of poor quality, the waterline system does not generate enough pressure, or if its use is required by legislation.

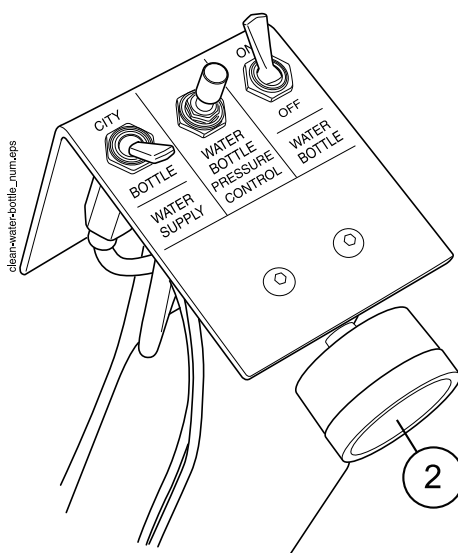
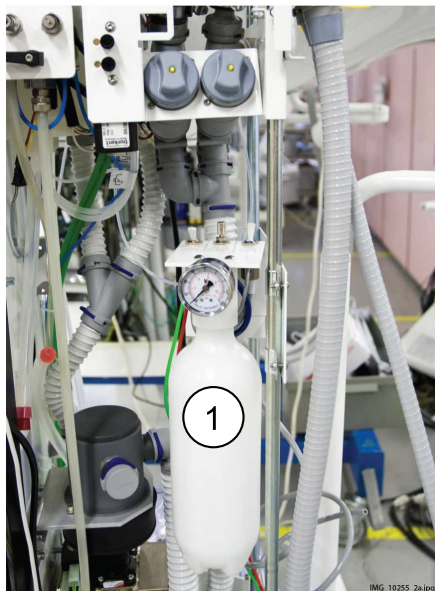

1. Clean-water bottle
2. Pressure monitor

The switches on the clean-water bottle assembly let you control the water supply.

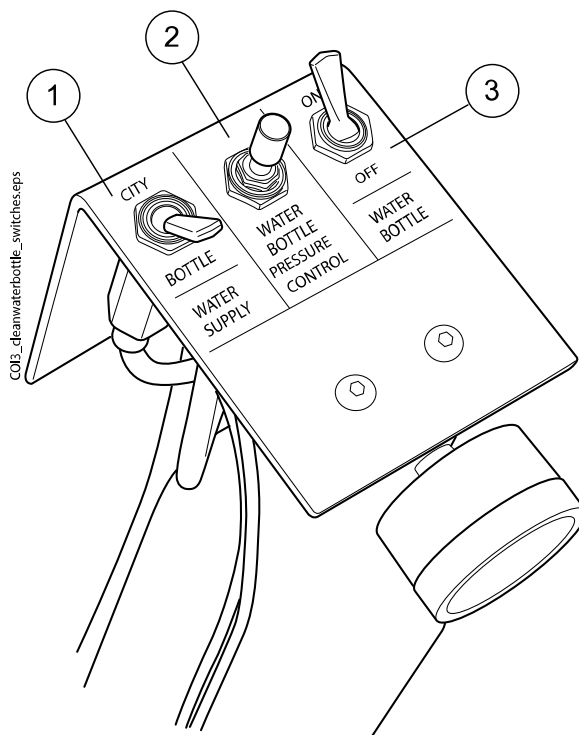

1. Water supply

Lets you select the water supply for your dental unit. Turn the switch toward 'CITY' to select domestic water, and toward 'BOTTLE' to select the clean-water bottle.

NOTE

If your dental unit is installed so that it has no domestic water, this switch is missing and the water supply for the dental unit is clean-water bottle only.

2. Water bottle pressure control

The pressure in the water bottle can be adjusted by turning the knob. The pressure can be checked from the pressure monitor and should be between 2.5 and 2.8 bar.

3. Water bottle

When the clean-water bottle is used (water supply -switch turned toward 'BOTTLE'), the water bottle -switch lets you turn the bottle on or off.

When the switch is toward 'ON', the pressure is maintained in the bottle, and the bottle can be used.

When the switch is toward 'OFF', you can detach the bottle, for example, for cleaning. Allow a few seconds for the pressure to drop before unscrewing the bottle.

29.2 Waterline cleaning

The waterlines of the dental unit should be cleaned once a week with a Planmeca approved waterline disinfectant. The solution is left in the unit overnight and the waterlines of the unit are flushed with water the next morning. The disinfectant should not be left in the waterlines for longer than one night.

CAUTION

Only Planmeca Planosil, Planmeca PlanPure or Alpro Bilpron disinfectant must be used. Planmeca does not guarantee the suitability of and is not liable for damages caused by other disinfectants.

NOTE

To avoid stains, possible disinfectant splashes should be wiped away immediately.

29.2.1 After the working day

About this task



NOTE

You can interrupt the flushing cycle by pressing Close. After the interruption, the dental unit can be used normally.

Steps

1. Open the dental unit door.

2. Remove the clean-water bottle.

First, turn the Water bottle switch toward 'OFF'. Then, take a hold of the bottom of the bottle, turn the bottle slightly so that the pin moves along the groove and pull the bottle downwards.

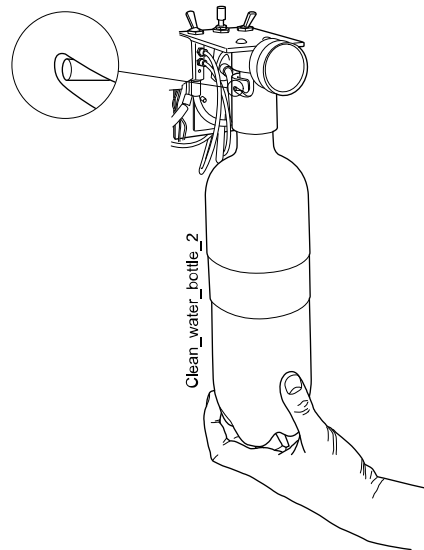

3. Empty the possible water from the clean-water bottle.
4. Fill the clean-water bottle with approx. 1 dl of Planmeca approved waterline disinfectant. The amount depends on the unit configuration.
The assistant's syringe uses about 1 dl of disinfectant. Thus, if the syringe is in use, add this amount to your calculations on the required disinfectant amount.
We recommend you keep record of how much disinfectant has been used.
5. Place the clean-water bottle back in its place in the dental unit and close the unit door.

NOTE

Ensure that the water supply switch is turned toward 'BOTTLE' and that the water bottle switch is turned toward 'ON'.



6. Press **Maintenance** to go into maintenance mode.
7. Remove the instrument handpieces from the instruments and clean them according to the manufacturer's instructions.
8. Place all water consuming instruments (including syringes) into the openings in the instrument flushing holder.
Optionally, in dental units with balanced instrument arms, you can remove the hoses of the instruments to be flushed from the instrument arms / instrument holders before placing the instruments in the flushing holder.
In dental units with hanging-tube instruments, the instruments to be flushed must be removed from the instrument holders before placing them in the flushing holder.

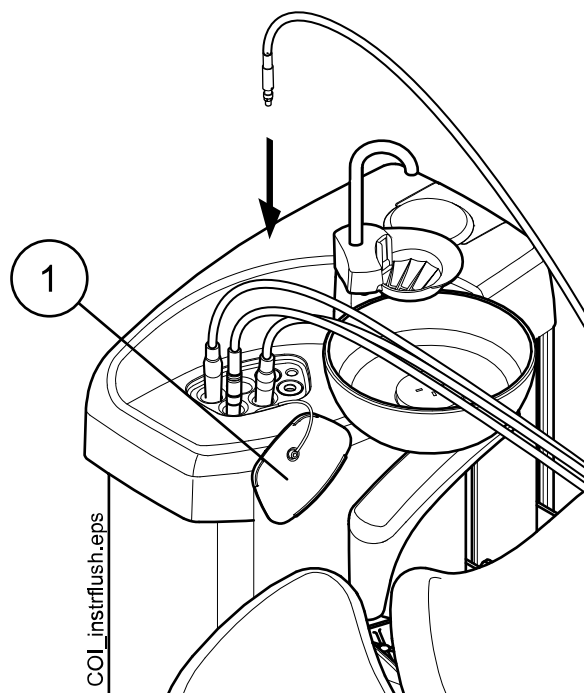

1 Flushing holder cover

9. Start the short flushing cycle.

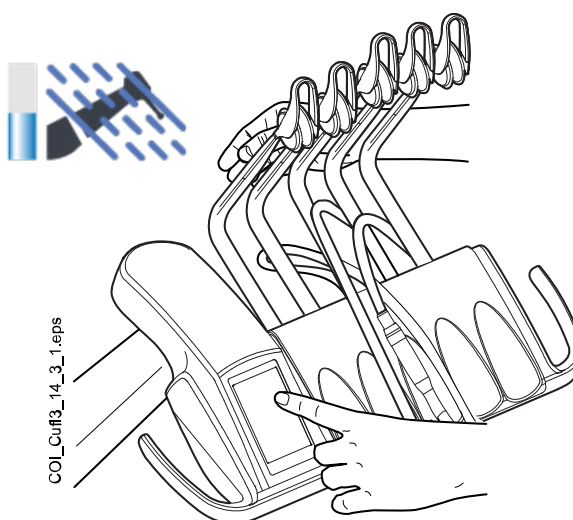

Balanced instrument arms: Start the flushing cycle by bending the instrument arms of those instruments (including syringe) that are to be flushed to an angle of at least 90° and simultaneously selecting **Short flushing** on the control panel.

Hanging-tube instruments: Start the flushing cycle by selecting **Short flushing** on the control panel.

The system will first identify the instruments and then each instrument hose is flushed with air and water for 30 seconds in its turn.

10. Release the instrument arms (if your dental unit is equipped with balanced instrument arms).
11. Turn the unit off and let the disinfectant affect in the unit overnight.

NOTE

Leave the instruments in the flushing holder overnight.

29.2.2 In the morning

Steps

1. Open the dental unit door.
2. Remove the clean-water bottle.

First, turn the Water bottle switch toward 'OFF'. Then, take a hold of the bottom of the bottle, turn the bottle slightly so that the pin moves along the groove and pull the bottle downwards.

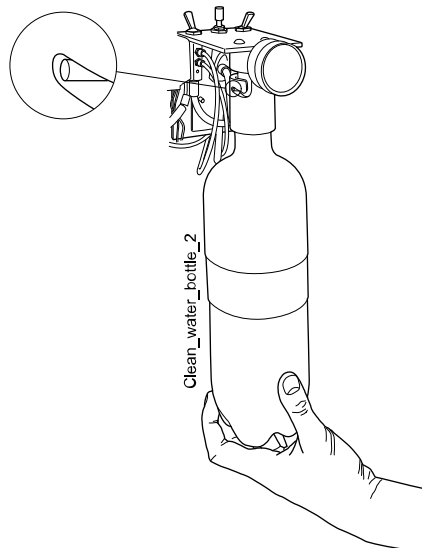

3. Rinse the clean-water bottle and fill it with clean water.
4. Place the clean-water bottle back in its place in the dental unit and close the unit door.
5. Start the short flushing cycle.

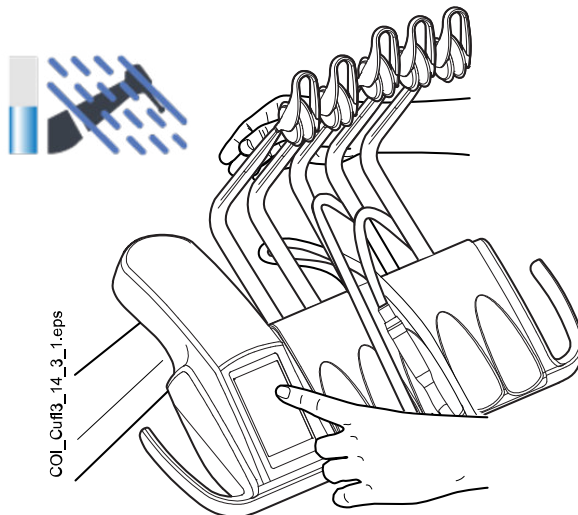

Balanced instrument arms: Start the flushing cycle by bending the instrument arms of those instruments (including syringe) that are to be flushed to an angle of at least 90° and simultaneously selecting **Short flushing** on the control panel.

Hanging-tube instruments: Start the flushing cycle by selecting **Short flushing** on the control panel.

The system will first identify the instruments and then each instrument hose is flushed with air and water for 30 seconds in its turn.

6. Release the instrument arms (if your dental unit is equipped with balanced instrument arms).
7. Repeat the flushing sequence in steps 5 and 6 at least three more times, or until the water is clean. If the clean-water bottle runs out of water, refill it.

If the water quality of the domestic water is good, you can also use the domestic water mode when performing the flushing.

8. **Balanced instrument arms:** Place the instrument hoses back in the instrument arms, and the instruments back in the instrument console.

Hanging-tube instruments: Place the instruments back in the instrument holders.

Results

The dental unit is now ready for use.

30 Planmeca Patrol by BWT

The Planmeca Patrol water filtration system is an optional means to adjust the hardness of the water and to remove particles as well as organic compounds that cause smell and taste.

Planmeca Patrol is available for dental units with

- no water system,
- Clean Water System (CWS), or
- Waterline Cleaning System (WCS).

Planmeca Patrol can not be installed to dental units with CWS with no city water available or to dental units with Planmeca WEK water disinfection system.

30.1 Replacing Planmeca Patrol filter

About this task

NOTE

The pictures in this section may not match the configuration of your dental unit, but the instructions apply for all configurations.

The Planmeca Patrol filter must be replaced every 6 months or when the dental unit has been unused for 4 weeks or longer. The replacement date can be checked from the label on the filter.

Steps

1. Switch off the mains water.
2. Switch off the dental unit.
3. Open the cuspidor door.
4. For easier access to the filter, turn out the Planmeca Patrol assembly from the dental unit.

- Remove the old filter (1) by rotating it clockwise.



- Mark the installation date and next replacement date (6 months after installation) on both sides of the new filter.

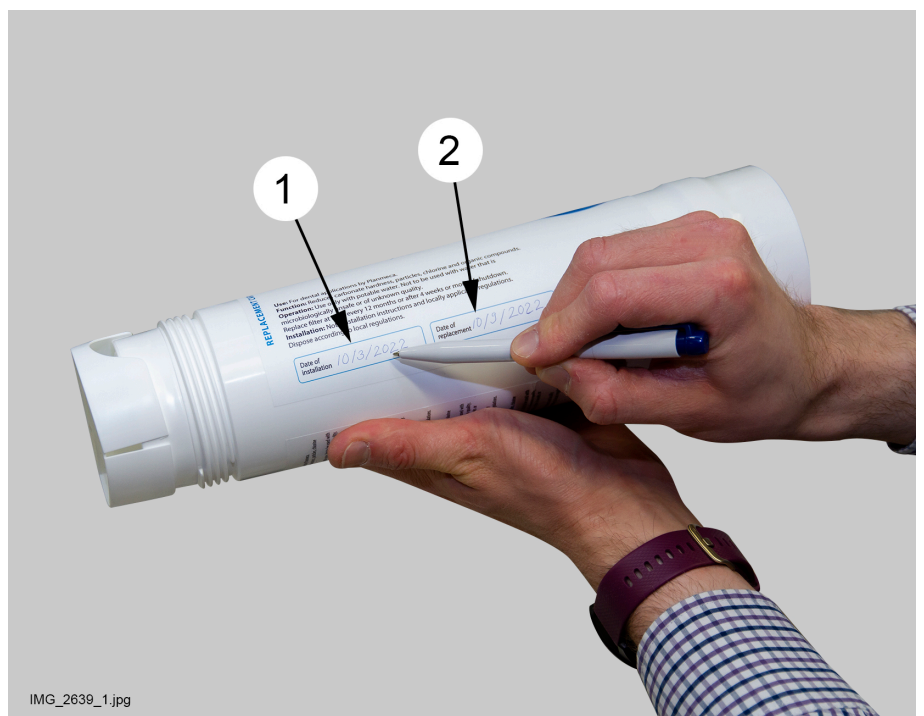

- Lift the new filter to the filter head and attach it by rotating it counterclockwise.
- Switch on the mains water.
- Switch on the dental unit.

10. Flush the filter.

NOTE

Alternatively to the flushing procedure described here, you can flush the filter by performing long instrument flushing twice.

10.a. Remove the plug (1) from the water outlet hose.

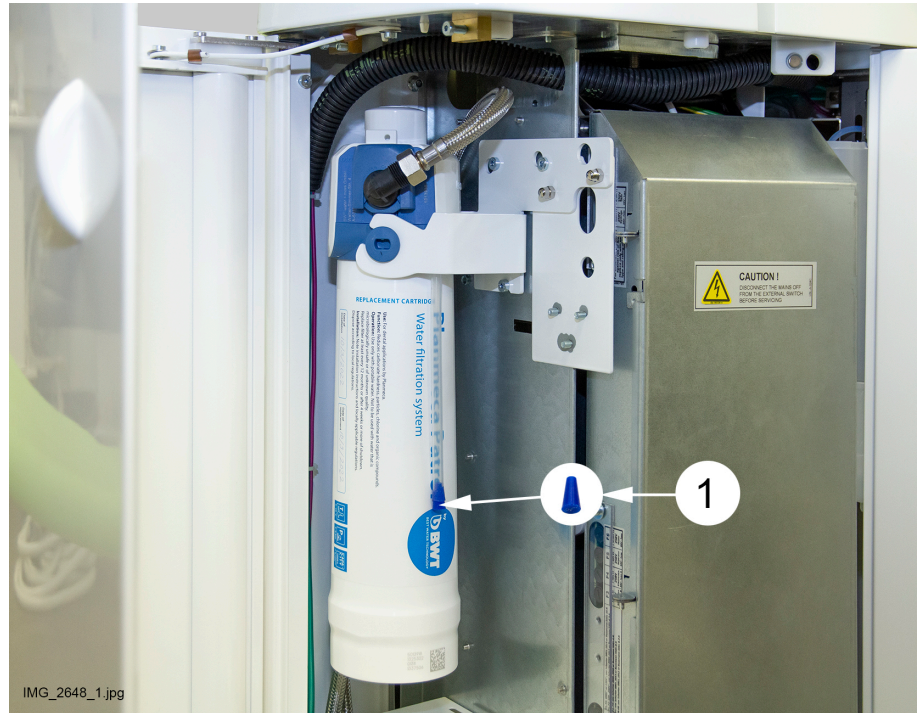

10.b. Open the flushing valve and run 1-2 litres of water from the water outlet hose (2) into a bucket (3).

The flushing valve is opened by turning the tap (1) above the filter head counter-clockwise. You can see a red marking on the tap when the tap is open.

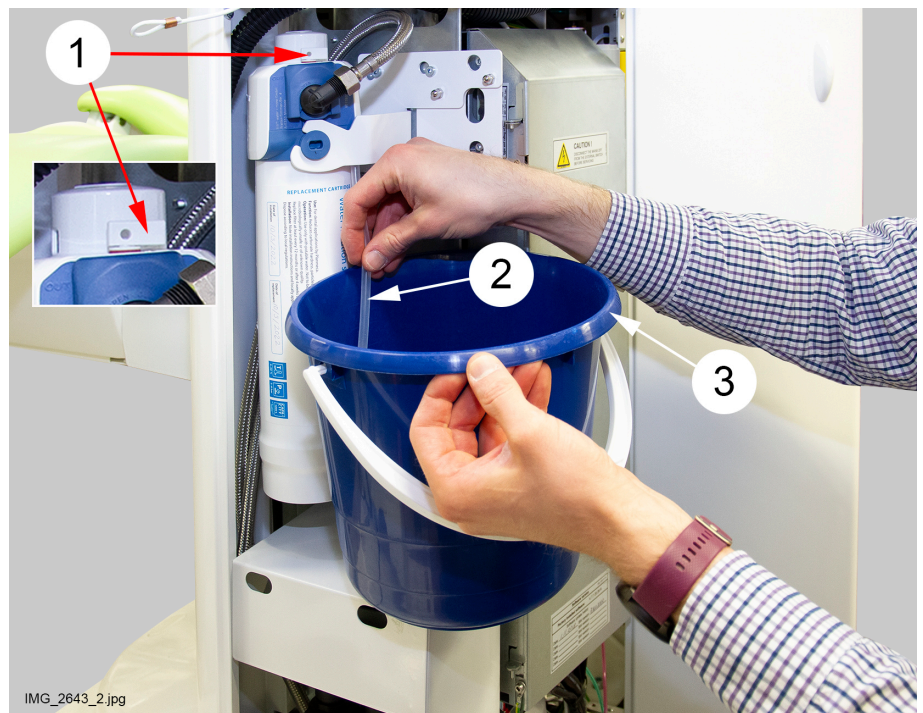

- 10.c. Close the flushing valve by turning the tap clockwise so that the red marking is no longer visible.
- 10.d. Plug the water outlet hose.
- 11. Turn the Planmeca Patrol assembly back into the dental unit.
- 12. Close the cuspidor door.

31 Help and error messages

31.1 Overview

The dental unit displays three types of safety messages: notifications, help messages and error messages.

Notifications are typically issued for guidance in maintenance situations, for example, when instruments are flushed. Notifications are blue in colour.

Help messages are green and provide helpful information for the user. They are displayed, for example, if you are using the unit or instrument incorrectly, or if the function is not allowed for some reason. The help message disappears automatically when the situation is corrected.



Some help messages have a **Close** button that allow you to close the message before it is automatically closed.



Error messages warn of a fault in the dental unit and require actions from the user. To correct the error situation, and thus to close the error message, follow the instructions in the message. Some error messages contain a **question mark** that you can press to receive more information about the error.

NOTE

The level of detail displayed in the error messages is configurable. Contact your Planmeca dealer.

When a help or error message is issued, it is displayed as a semi-transparent bar at the top of the control panel.

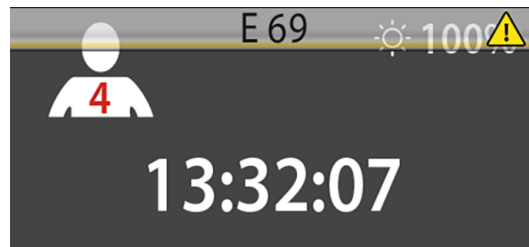

Press the help/error bar to open the help/error message.

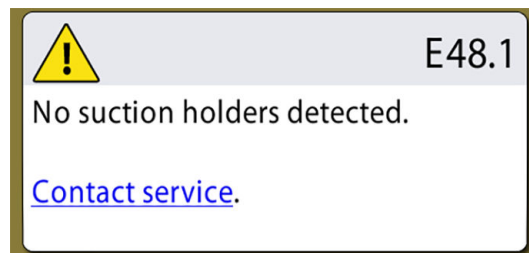

When you press the hyperlink *Contact service* in the help or error message, the service contact details are displayed. The details are only to be changed by a qualified Planmeca service technician.



The **Minimise** button allows you to minimise the help or error message to a help or error bar.

31.2 Viewing help and error message history

About this task

The dental unit keeps a log of all help and error messages. It can be viewed in the *About this unit* window.

Steps



1. Press **Program**.



2. Press **About this unit**.

NOTE

The following is an example only and does not necessarily portray the actual situation.

About this unit	
Unit type	Compact i v2
Unit serial number	UTTF123456
Unit SW version	7.11.0.302.B >
Service	>
Network settings	10.0.0.146 >
Message history	>
Bluetooth	>
Licences	>
Designed and Assembled by Planmeca in Finland	

3. Press **Message history**.

The following window opens.

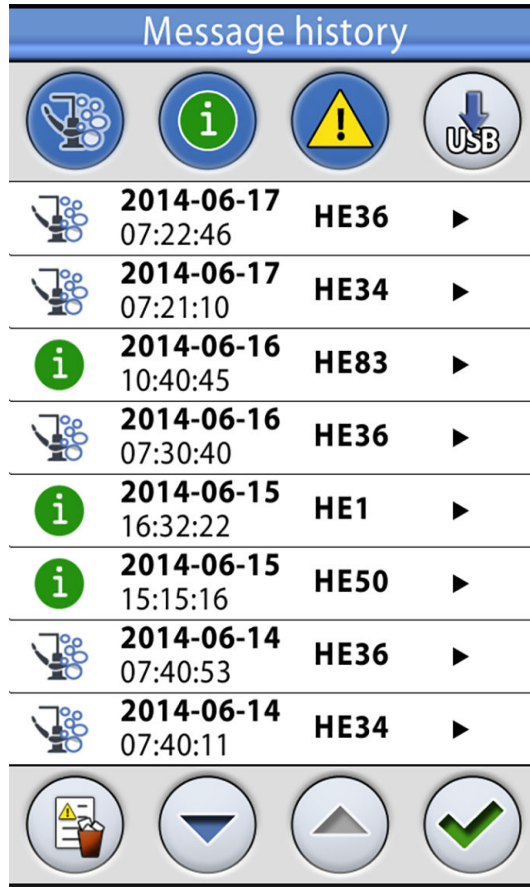

Move up and down on the list with the arrow buttons.

When you click on a message, the message is opened into a new window.

The message history window can be filtered by message type.

In the picture above, all types are listed:

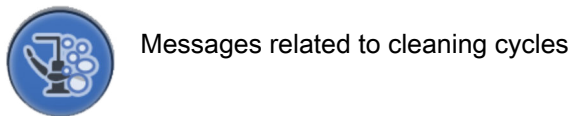

4. Optional: Filter messages by toggling the **Message type** buttons.

A grey button means that the message type is not listed, and a blue button that it is listed.



5. Optional: Delete the message history by pressing **Delete message history**.

A confirmation message is displayed. Confirm the deletion by pressing **OK**.

NOTE

Carefully consider when the deletion of message history is appropriate as it contains information that is valuable to the Planmeca service technician.



6. Press **OK** to close the window.

NOTE

The Save message history to USB -option is meant to be used only by a qualified Planmeca service technician.



31.3 Help messages

NOTE

The WCS related help messages can be disabled. Contact your Planmeca dealer.

NOTE

The list may contain help messages related to features that are not part of your unit configuration.

H 1 Amalgam collector is 95% full.

Replace or empty the collector as soon as possible, or at least before the next patient. Pressing the program button allows to continue the operation until the collector is 100% (totally) full.

H 2 Amalgam collector is 100% full.

Replace or empty the collector immediately. The suction system cannot be used before the collector is emptied or replaced.

H 3 Patient chair cannot be driven down because safety switch is activated.

Check that the space under the seat is free and nothing is touching the plate at the bottom. The chair can be driven normally after the possible obstruction has been removed.

H 3.1 Move mannequin arm back to driving sector to enable height adjustment.

The mannequin arm must be horizontally positioned to the driving sector to enable driving the mannequin arm up/down. Otherwise there is a risk of colliding the mannequin arm with the table.

H 4 This left-hand instrument position allows only syringe.

The leftmost position in the console is reserved for the syringe only. Replace this instrument with a syringe. Place the other instrument to one of the four right-hand places.

H 5 This instrument position does not accept syringe.

Remove the syringe from this position and replace it with any other kind of instrument. The syringe must be placed in the leftmost place.

H 6 Patient chair cannot be driven when instrument is in use.

Stop the instrument (release the foot control pedal) to be able to run the chair.

H 7 Patient chair up/down movement is not allowed when cuspidor door is open.

Close the cuspidor door to be able to run the chair up/down or to a pre-programmed position.

H 8 Chair height can not be programmed this high in automatic positions for patient safety reasons.

Run the chair slightly down to be able to program this position into memory.

H 9 This scaler cannot currently be used with this unit.

This scaler needs a dedicated electronics that is not installed, or the scaler electronics installed is not compatible with this scaler.

H 10 Wait while configuring the dental instrument setup.

Wait a few seconds for the unit to check your instrument configuration, since it has changed.

H 11 Software download mode is on.

H 12 Unit's internal error reporting is disabled.

The unit operates normally but no errors are reported (exhibition use). Use service mode n.15 to turn error reporting back on.

H 13 Instrument cannot run because of patient security violation.

Return the foot control pedal once to the middle position to start the instrument. Instruments do not start if the standard foot control pedal is already pushed to the right or left when the instrument is picked up from the instrument console.

H 14 This dental instrument is not recognised (new type of instrument).

To be able to operate this new instrument the MCB software must be updated.

Contact your Planmeca dealer.

H14.1 Instrument presets are reset to defaults.

Instrument presets are faulty. Presets are reset to defaults.

H14.2 Old type of instrument is detected. Dental unit console does not support old type of instrument.

Replace instrument by supported instrument.

H 15 This button has no function at the moment.

Instruments: Pick up a dental instrument before attempting to alter its settings; or if the instrument is selected, this function is not allowed with this instrument. Other buttons: the unit does not have this function.

H 16 Operating light is dimmed and polymerisation light can be used.

This feature enables easier work with composite materials, minimising the risk of operating light induced curing. This feature is triggered by picking up and returning the polymerisation light to its holder without starting it. The operating light returns to normal at the same instance any control is touched or another instrument selected. The feature can be disabled.

Contact your Planmeca dealer.

H 17 No syringe connected to instrument console.

The console syringe must be re-connected, otherwise there is an air-leak from the syringe quick-connector whenever an instrument or device that requires air pressure is used.

H 18 No instrument hose connected to this instrument place.

The instrument is picked up, but there is no hose connected at this location. Check that all hoses go to the right instrument arms.

H 19 No syringe connected to connector located on cuspidor.

The assistant's syringe must be re-connected, otherwise there is an air-leak from the assistant's syringe QC whenever an instrument or device that requires air pressure is used.

Contact your Planmeca dealer.

H 20 Wrong instrument connected to syringe connector on cuspidor or assistant instrument configuration is wrong.

Contact your Planmeca dealer.

H 21 Flow of both spray air and spray water are programmed to zero (no flow).

Contact your Planmeca dealer.

Enter the spray programming mode to set a flow other than zero.

H 22 Main air or water valve is set to be always closed in SM 12 (air) /13 (water).

This is a reminder that either of the main valves has been set to be always closed. The setting may be changed in service modes SM 12 (air) and SM 13 (water).

H 23 Automatic/manual chip blow cannot be used when sterile water function is selected.

H 24 Programming of selected setting is disabled.

The programming of the selected setting is disabled.
Contact your Planmeca dealer.

H 25 Planmeca Compact e help message: Patient chair cannot be driven into automatic chair position.

Contact your Planmeca dealer.

H 26 Drive chair upwards, then lower backrest. If patient chair is attached to unit, chair's automatic positions are not switched on.

Drive the chair upwards before lowering the backrest. If this help message is shown while the patient chair is attached to the unit, it means that you have forgotten to switch on the chair's automatic positions. To clear the message, put the operation mode switch on the cuspidor side of the chair base in the "AUTO" position (switch up).

H 27 Drive backrest upwards, then lower chair. If patient chair is attached to unit, chair's automatic positions are not switched on.

Drive the backrest upwards before lowering the chair. If this help message is shown while the patient chair is attached to the unit, it means that you have forgotten to switch on the chair's automatic positions. To clear the message, put the operation mode switch on the cuspidor side of the chair base in the "AUTO" position (switch up).

H 28 Planmeca Compact WE's help message.

Connect the lifter cable.

H 29 Drive chair downwards, then lower backrest. If patient chair is attached to unit, chair's automatic positions are not switched on.

Drive the chair downwards before lowering the backrest. If this help message is shown while the patient chair is attached to the unit, it means that you have forgotten to switch on the chair's automatic positions. To clear the message, put the operation mode switch on the cuspidor side of the chair base in the "AUTO" position (switch up).

H 30 Close water tap. Fill container with disinfectant up to groove and attach to unit.

H 31 Switch unit off, leave disinfectant in unit overnight (min. 8 h).

When unit is turned back on, disinfection procedure continues.

H31.1 Remove container, fill it up to groove with water and attach to unit.

H31.2 Attach container filled with water.

H 32 Container flushing completed.

Remove container from unit.

H 33 Open water tap.

H 34 No instruments selected when starting instrument flushing or waterline cleaning.

Select at least one instrument and syringe (remove from holder, bend the instrument arms) .

H 35 Instruments are locked for safety reasons.

Select instruments, place them in flushing holder, and press Instrument flushing button to start instrument flushing.

H35.1 Waterline cleaning cancelled or failed. Remove container.

Make sure water tap is open. Select instruments, place them in flushing holder and press Instrument flushing button to start instrument flushing.

H 36 Flushing ready. Return instruments to instrument console.

Also bend and release syringe's instrument arm once.

H36.1 Instrument flushing completed, but water flow was not detected for one or more instruments.

Run instruments for a while with spray water to ensure instrument flushing is sufficient.

H36.8 Low water pressure during final flushing.

Perform long instrument flushing to ensure instruments are flushed.

H 37 Waterline cleaning has been interrupted.**H 38 Low water pressure during final rinsing.**

When waterline cleaning is finished, perform long instrument flushing to ensure instruments are flushed.

H 39 Syringe misplaced or its flow not detected in waterline cleaning.

Return syringe to console. Then, select syringe (bend instrument arm) again and place it carefully in flushing holder.

H 40 Too many Bien-Air MX brushless micromotors.

A maximum of two is allowed.

H 41 Insert suction tubes to suction tube cleaning holder, add disinfectant and press green start button (upper button).**H41.1 Insert suction tubes to suction tube cleaning holder.****H41.2 Remove suction tubes from holder to start suction cleaning.****H 42 Suction cleaning completed. Return suction tubes to suction holder and close suction cleaning cover.****H42.1 Suction cleaning completed. Return suction tubes to suction holder.**

H 43 Suction cleaning cancelled. Return suction tubes to suction holder.

H 44 Incorrect suction tube amount detected. Return them to suction holder, place them back to suction tube cleaning holder and start cleaning.

H 45 Set WMS to Domestic Water Supply -mode and wait until WMS bottle is full. Then start suction cleaning.

Suction cleaning can not be used when WMS is set to Bottled Water -mode.

H 46 Suction use is forbidden or there are no suction tubes in dental unit configuration.

The value of service mode n.83 is 0.

H 47 Suction disinfectant pressure is low. (In automatised suction cleaning: Fill suction disinfectant container).

H47.1 Suction disinfectant level low. Fill suction disinfectant container.

H47.2 Suction disinfectant container filled.

H 48 WMS must be set to Bottled water off and Bottle on -modes before starting suction cleaning.

Bottled water off = domestic water is used Bottle on = bottle is used; domestic water is run through the bottle.

H 50 No cup in cup holder. Sensor does not recognise cup when pressing cup fill button.

Place a cup on the cup holder. Or change the setting of service mode n 116.

H 51 Bowl or tray is above patient chair when driving chair up.

If the unit has a bowl or a tray, move it to the home position. If the unit has an OP delivery arm safety switch, check that the OP delivery arm is not blocking the chair movement.

H 52 Patient chair can not be driven upward because safety switch of side delivery arm is released.

H52.1 Mannequin arm can not be driven upward because safety switch under the table is released.

H 53 Patient chair can not be driven downward because safety switch of side delivery arm is released.

H53.1 Mannequin arm can not be driven downward because safety switch of the arm is released.

H53.2 Patient chair can not be driven upward because the lift height is limited in service mode SM179.

H 54 Cup is inserted in cup holder.

Remove the cup and make sure the cup fill tube is above the bowl.

H 55 Disinfectant container attached. To start waterline cleaning, select instruments and press Waterline cleaning button.**H 57 Vision action failed. Select patient in Romexis.**

Select patient in Planmeca Romexis before performing Solanna Vision action.

H 59 OTR torque calibration needed.

For the OTR torque measurement result to be accurate, always perform calibration when changing the handpiece.

H59.1 OTR torque calibration started.

Do not touch the file during calibration. The file runs with full speed during calibration.

H59.2 OTR torque calibration cancelled.**H59.3 OTR torque calibration failed.**

Try calibration again and ensure that nothing touches the file during calibration. If calibration still fails after multiple attempts, contact service.

H59.4 OTR torque calibration performed successfully.**H59.5 OTR torque calibration interrupted.****H 60 WMS: Container almost empty in Domestic water supply -mode.**

Reduce water use for a moment.

H 61 WMS: Container almost empty in Bottled water -mode.

Reduce water use and fill the container as soon as possible.

H 62 WMS: Container switch is turned off.

Switch on the container switch.

H 63 Cuspidor door is open.

Close the door.

H 64 Fill container with disinfectant over upper sensor.**H 65 Fill container with water over upper sensor.****H 66 Wait 8 hours or switch unit off for the night.****H 67 Instrument flush cancelled. Return instruments to instrument console.**

H 68 Romexis connection lost.

Make sure the Ethernet cable is attached and Romexis is running.

H 69 Unable to create a new user. Maximum amount of local users exceeded.

H 70 Brushless micromotor is stuck or broken.

H 71 Romexis user ID already in use.

Check the ID, select another one, or allow rebind in Romexis.

H 72 Incompatible Romexis version.

PlanID is not supported with this version of Romexis.

H72.1 Incompatible Romexis version for current instrument.

User settings for currently active instrument can not be used. Romexis version does not support user instrument settings or presets for currently active instrument. Check the instrument settings before using instrument and update Romexis.

H 73 Failed to copy user profile from Romexis.

Failed to copy user profile from Romexis.

H73.1 Failed to save user settings.

H 74 PlanID reader missing.

PlanID reader is either missing or not functional.

H 75 Annual maintenance in xx days.

Contact service for annual maintenance.

H 76 Annual maintenance performed.

H79.1 Serial number chip missing.

Serial number chip missing. Contact service.

H 80 Headrest length safety feature activated when driving headrest. Check that nothing is blocking headrest movements.

Check that nothing is blocking the headrest movement. The headrest can be driven normally after the possible obstruction has been removed.

H80.1 Headrest length drive limit activated when driving headrest.

Check that nothing is blocking headrest movements.

Faulty length motor, motor cable, non-lubricated slider rail or position potentiometer may cause this problem.

H 81 Headrest angle B safety feature activated when driving headrest. Check that nothing is blocking headrest movements.

Check that nothing is blocking the headrest movement. The headrest can be driven normally after the possible obstruction has been removed.

Faulty angle B motor, motor cable or position sensor may cause this problem.

H81.1 Headrest angle A drive limit activated when driving headrest.

Check that nothing is blocking the headrest movement.

Faulty angle A motor, motor cable or position sensor may cause this problem.

H 82 Connecting to wireless foot control was successful.

Connection was established with the requested foot control.

H 83 Foot control handle pressed down.

Release the foot control handle.

H 84 Connecting to wireless foot control failed.

Connection with the requested foot control could not be established. Make sure the foot control is active (connect to a charger, if possible), is in the vicinity of the unit, and try again.

H 85 Software update denied. Chair was moving or instrument was in use while starting software update.

The chair was moving or an instrument was in use while starting the software update.

H 86 Software update denied. Incorrect control panel type was detected while starting software update.

An incorrect control panel type was detected while starting the software update.

H 87 Software update halted. Activate the wireless foot control by pressing the handle.

Wireless foot control has to be activated before it can be updated.

H 88 Wireless foot control configuration was successful.

Wireless foot control channel and power settings were successfully changed.

H 89 Wireless foot control configuration failed.

Wireless foot control channel and power settings could not be changed. Make sure the foot control is active (connect to a charger, if possible), is in the vicinity of the unit, and try again.

H90.1 Measure water chlorine level.

Run at least 50 ml of water from the syringe to the cup. Move the test strip back and forth in the water for 30 seconds. Compare the strip colour with the colour scheme. Select the chlorine level on the control panel according

to the measurement. Below 0.2 (LOW), 0.2 - 0.8 (OK), above 0.8 (HIGH). If the chlorine level is continuously too low, contact service.

H90.6 Measured chlorine level low.

Normal use chlorine level increased by +15%.

H90.7 Measured chlorine level OK.

No change to normal use chlorine level.

H90.8 Measured chlorine level high.

Normal use chlorine level decreased by -5%.

H 94 Clock calibration failed. Maximum calibration range exceeded.

H 95 Patient chair automatic position cannot be reached because legrest is unlocked or armrests are blocking movement.

H 96 PlanID tag already in use.

PlanID tag assigned to another user.

H96.1 Different user already logged in.

The unit has rejected a login request because a different user is already logged in.

H 97 Failed to assign PlanID tag to user.

Check Romexis connection.

H 98 User not found.

User not found with this PlanID tag. Create a new user or select an existing Romexis user and assign the PlanID tag.

H98.1 User login failed.

Retry login or reboot the unit. If problem persists, contact service.

H98.2 RFID unknown.

The RFID is unknown to the system.

H 99 Unit has been switched off without performing long flushing after water has been used. Perform long flushing.

This help message can be disabled, contact your Planmeca dealer.

HE200 Detected new software update. Confirm to install?

HE201 Detected new software update SD-card. Confirm to install 5.3.0.9.R ?

HE210 Software update. Installing to Control panel bootloader sw. DO NOT TURN POWER OFF.

Do not turn the power off while the software is being updated.

HE212 Software update. Installing to Control panel application sw. DO NOT TURN POWER OFF.

Do not turn the power off while the software is being updated.

HE214 Software update. Installing to Control panel application sw. DO NOT TURN POWER OFF.

Do not turn the power off while the software is being updated.

HE216 Software update. Downloading from server. DO NOT TURN POWER OFF.

Do not turn the power off while downloading software from the server.

HE218 Software update. Installing to Main PCB. DO NOT TURN POWER OFF.

Do not turn the power off while the software is being updated.

END Flushing completed. Remove syringe from flushing holder and return it to console. If syringe is removed, return it to flushing holder.

DOOR Cuspidor door is open.

Close the door.

FC.LD Move foot control pedal to leftmost position. Press pedal down and hold. While holding, push centre knob briefly in 'chair up' direction.

Move the foot control pedal to the leftmost position. Press the pedal down and hold. While holding, push the centre knob briefly in the 'chair up' direction.

FC.LU Move foot control pedal to leftmost position and hold. While holding, push centre knob briefly in 'chair up' direction.

Move the foot control pedal to the leftmost position and hold. While holding, push the centre knob briefly in the 'chair up' direction.

FC.CD Press foot control pedal down and hold. While holding, push centre knob briefly in 'chair up' direction.

Press the foot control pedal down and hold. While holding, push the centre knob briefly in the 'chair up' direction.

FC.CU Keep foot control pedal in rest position (centre). Push centre knob briefly in 'chair up' direction.

Keep the foot control pedal in the rest position (centre). Push the centre knob briefly in the 'chair up' direction.

FC.RD Move foot control pedal to rightmost position. Press pedal down and hold. While holding, push centre knob briefly in 'chair up' direction.

Move the foot control pedal to the rightmost position. Press the pedal down and hold. While holding, push the centre knob briefly in the 'chair up' direction.

FC.RU Move foot control pedal to rightmost position and hold. While holding, push centre knob briefly in 'chair up' direction.

Move the foot control pedal to the rightmost position and hold. While holding, push the centre knob briefly in the 'chair up' direction.

FC.-- To exit foot control calibration mode, press and hold down calibration switch for 4 seconds.

H 7003 Control panel is temporarily disabled due to interference on touch screen.

Make sure the touch screen is clean and dry.

If the problem continues, contact service.

31.4 Error messages

The error messages are mainly intended to assist the technician. If an error message is displayed, contact service.

For more detailed information, see *Planmeca Compact i Touch/Classic technical manual*.

NOTE

The lists may contain error messages related to features that are not part of your unit configuration.

31.4.1 General error messages

E1.01 Main water valve short circuit.

Disconnect valve and check if error disappears.

E1.02 Main air valve short circuit.

Disconnect valve and check if error disappears.

E1.03 Bowl rinse valve short circuit.

Disconnect valve and check if error disappears.

E1.04 Cup filling valve short circuit.

Disconnect valve and check if error disappears.

E1.05 Water flush valve short circuit.

Disconnect valve and check if error disappears.

E1.06 Separator pulse valve short circuit.

Disconnect valve and check if error disappears.

E1.07 Ejector valve short circuit.

Disconnect valve and check if error disappears.

E1.08 Extra out 1 short circuit.

Disconnect valve and check if error disappears.

E1.09 Extra out 2 short circuit.

Disconnect valve and check if error disappears.

E1.10 Extra out 3 short circuit.

Disconnect valve and check if error disappears.

E1.11 Separator start signal / Microvac's start valve short circuit.**E1.12 Assistant syringe water valve short circuit.**

Disconnect valve and check if error disappears.

E1.13 Separator alarm reset signal short circuit.

Disconnect output and check if error disappears.

E1.14 PLANET output (ELMP) short circuit.

Disconnect output and check if error disappears.

E2.01 Incoming water valve open circuit.

The following list indicates which output is causing the trouble.

These errors can be detected when the circuit is dead.

E2.02 Incoming air valve open circuit.

Error can be detected when circuit is dead.

E2.03 Bowl rinse valve open circuit.

Error can be detected when circuit is dead.

E2.04 Cup filling valve open circuit.

Error can be detected when circuit is dead.

E2.05 Main Control PCB output open circuit warning.**E2.06 Separator pulse valve open circuit.**

Error can be detected when circuit is dead.

E2.07 Main Control PCB output open circuit warning.**E2.08 Main Control PCB output open circuit warning.****E2.09 Main Control PCB output open circuit warning.****E2.10 Main Control PCB output open circuit warning.****E2.11 Separator start signal open circuit / Microvac valve open circuit.****E2.12 Assistant syringe water valve open circuit.**

Error can be detected when circuit is dead.

E2.13 Separator alarm reset signal open circuit.

Error can be detected when circuit is dead.

E2.14 Main Control PCB output open circuit warning.

E2.15 Not used or not in the manuals.

E3.1 Incoming air pressure compared to water pressure is too low.

Ensure that air pressure main switch is on. If problem persists, contact service.

E3.2 Internal water pressure too low.

Check dental unit's incoming water pressure. Ensure that dental unit inlet water tap is open.

E3.4 Internal air pressure (after regulator) is too low.

Ensure that air pressure main switch is on. If problem persists, contact service.

E3.5 Internal air pressure (after pres. regulator) is too high.

Check pressure regulator, pressure sensor and pressure block connector.

E3.6 Waterline cleaning feed pressure too low.

Check and adjust waterline cleaning feed pressure. Replace waterline cleaning feed regulator if problem still exists.

E3.7 Waterline cleaning flush pressure too low.

Check dental unit's incoming water pressure. Ensure that dental unit inlet water tap is open.

E4.1 Short circuit in cable from MCB to control panel / suction holder in branch 1.

E4.2 Short circuit in cable from MCB to control panel / suction holder in branch 2.

E4.3 Communication bus (CAN) is not operational or CAN devices are disconnected (foot control, operation light, motorised headrest, uWmc).

E4.4 Communication bus (Console CAN) is not operational.

E5 Unsupported device attached.

Compact i Classic does not support the use of certain devices. Contact service for necessary upgrade.

E6.01 Cuspidor up -safety circuit error.

Safety circuit self-check failed.

E6.02 Cuspidor down -safety circuit error.

Safety circuit self-check failed.

E6.03 Chair down -safety circuit error.

Safety circuit self-check failed.

E6.04 Bowl up -safety circuit error.

Safety circuit self-check failed.

E6.05 Bowl down -safety circuit error.

Safety circuit self-check failed.

E6.07 Console up -safety circuit error.

Safety circuit self-check failed.

E6.08 Console down -safety circuit error.

Safety circuit self-check failed.

E6.09 Emergency stop -safety circuit error.

Safety switch jumper missing from Main PCB connector P35. Contact service.

31.4.2 Power supply related error messages**WARNING**

If a fuse has blown, contact your Planmeca dealer. Fuses must be changed only by a qualified Planmeca service technician.

E7 Power supply related error messages. IPS voltage failure on MCB.**E7.01 Instrument power supply overcurrent shutdown.**

Instrument power supply may be shortcircuited or selected instrument hose may be faulty.

E9 Internal operating voltage too low. Unit functionality may be limited.

E10 Internal operating voltage too high.

E11.1 OP-light fuse (F5) and/or Water heater fuse (F7) has blown on the MCB.

E11.2 Separator fuse (F6) and/or Syringe heater fuse (F8) has blown on the MCB.

E11.3 Either of the +24V electronics fuses (F9 or F10) has blown on the MCB.

E11.4 Rectifier D5 or D1 short circuit or either of the 24V electronics fuses (F3 or F4) has blown on the MCB. Chair, instrument and headrest control not allowed.

E11.5 Separator fuse (F5) has blown on the MCB.

E11.6 Water heater fuse (F6) has blown on the MCB.

E11.7 Syringe heater fuse (F7) has blown on the MCB.

E11.8 Polymerisation light fuse (F8) has blown on the MCB.

E12.1 SELV voltage too low. Unit functionality may be limited.

E12.2 SELV voltage too high.

E13 Mains frequency outside acceptable range.

E14 IPS temperature measurement sensor error.

E15 IPS heatsink is running too hot on MCB.

E16 Attached scaler electronics is of new type.

E16.1 New type of scaler electronics is attached to MCB.

Update MCB software.

E16.2 New type of scaler electronics is attached to IMUX.

Update MCB software.

E16.3 Scaler electronics slot does not match with scaler hose connection.

E16.4 Other instrument than scaler is connected to slot where scaler electronics is.

E17 Power Supply related error messages.

E18 Power Supply related error messages.

31.4.3 Control panel related error messages

E19.1 Control panel in branch 1 is of new type.

Update MCB software.

E19.2 Control panel in branch 2 is of new type.

Update MCB software.

E20.1 Control panel 1 button stuck.

Control panel button is stuck during self test.

E20.2 Control panel 2 button stuck.

Control panel button is stuck during self test.

E21 Control panel related error messages.

E22 Control panel related error messages.

31.4.4 Instrument related error messages

E23 Polymerisation light bulb has blown or is not properly attached to socket.

The MCB monitors the current flowing from the IPS to the polymerisation light bulb. If the current is abnormally small, this error is generated. Check the bulb and the condition of the bulb socket. Some lights (LYSTA) have in series with the bulb connected a temperature fuse that might have triggered (overheating). Check also the condition of the quick-connector pins. If it still does not come on, check that the micromotor or the scaler operates to make sure that the cables in the arm between the MCB and IMUX are OK.

E23.1 Instrument overtemperature error.

Ensure that the instrument handpiece is in proper condition. Heavy use for long time may cause overtemperature error.

E23.2 Micromotor error; phase missing.

Check that the micromotor and hose are connected. If the problem persists, the micromotor may be faulty or the hose broken. Contact service.

E23.3 Instrument undervoltage error.

E23.4 Instrument power protection error.

E23.5 Instrument EEPROM error.

E23.6 Instrument overvoltage error.

E23.7 Instrument data communication error.

Check that instrument hose is properly connected. Do not unmount hose when instrument is selected.

E23.8 Apex locator / Morita micromotor PCB failure

E23.9 Unable to save instrument settings to selected preset.

E25 Satelec mini LED polymerisation light requires newer IMUX PCB version.

The use of the Satelec mini LED requires newer IMUX PCB version.

31.4.5 Instrument multiplexer related error messages

E28.1 Reference resistor signal out of bounds when unit is switched on.

E28.2 Active instrument signal out of bounds.

Error in hose identification system in IMUX. Ensure that the instrument's quick connector is properly attached.

E28.3 Syringe signal out of bounds.

Error in hose identification system in IMUX. Ensure that the instrument's quick connector is properly attached.

E28.4 Reference resistor signal out of bounds when instrument is activated.

Ensure that the instrument's quick connector is properly attached.

E28.5 Syringe signal changes during use (blinking).

Error in hose identification system in IMUX. Ensure that the instrument's quick connector is properly attached.

E29 Voltage error in fibre light power supply in IMUX.

If there is a problem with one instrument only, replace the hose. If the problem is with several instruments or the hose is ok, contact service.

E32.1 IMUX is not responding. IMUX cable disconnected or failure in cable or IMUX.

The MCB generates this error if there is any reason why it cannot communicate with the IMUX.

E32.2 IMUX software is not compatible (IMUX is of new type) with MCB software.

E32.3 IMUX data error (cable short circuit).

E32.4 IMUX communication error.

E32.5 Wrong IMUX type or wrong unit type.

E33.1 Syringe select valve short circuit.

E33.2 Instrument 1 select valve short circuit.

E33.3 Instrument 2 select valve short circuit.

E33.4 Instrument 3 select valve short circuit.

E33.5 Instrument 4 select valve short circuit.

E33.6 Instrument multiplexer related error messages.

E33.7 Drive/Cooling air valve short circuit.

E33.8 Air coolant valve short circuit.

E33.9 Water coolant valve short circuit.

E34.1 Syringe select valve open circuit.

E34.2 Instrument 1 select valve open circuit.

E34.3 Instrument 2 select valve open circuit.

E34.4 Instrument 3 select valve open circuit.

E34.5 Instrument 4 select valve open circuit.

E34.6 Instrument multiplexer related error messages.

E34.7 Drive/Cooling air valve open circuit.

E34.8 Air coolant valve circuit.

E34.9 Water coolant valve circuit.

E35.1 Drive/Cooling air pressure sensor output below 0.2 V.

E35.2 Air coolant pressure sensor output below 0.2 V.

E35.3 Water coolant pressure sensor output below 0.2 V.

E35.4 Differential pressure sensor output below 0.2 V.

E36.1 Drive/Cooling air measurement over range.

Check if micromotor handpiece has air- and waterlines. Check if instrument, handpiece or hose is blocked.

E36.2 Spray air measurement over range.

Check if micromotor handpiece has air- and waterlines. Switch off spray water and air if there are no air- and waterlines in instrument or handpiece.

E36.3 Spray water measurement over range.

Check if micromotor handpiece has air- and waterlines. Switch off spray water and air if there are no air- and waterlines in instrument or handpiece.

E36.4 Differential pressure sensor output above 5 V.

E37 Pressure sensor cable not properly attached to IMUX.

E39 Drive (cooling) air valve control servo cannot maintain pressure to instrument.

E42 Air coolant (spray air) control servo cannot maintain required pressure.

E45 Water coolant (spray water) control servo cannot maintain required pressure.

31.4.6 Suction holder related error messages

E47 Suction holder is of new type.

The recently attached suction holder is of a new type and it is not recognised by the control system. Update the MCB software. The new software is also compatible with the older type suction holders.

E47.1 Suction holder in branch 1 is of new type.

E47.2 Suction holder in branch 2 is of new type.

E48.1 No suction holders detected.

If the information given to the unit in the service mode is in conflict with the detected number of suction holders, this error is generated. The unit is aware of a built-in separator, but cannot find a functioning suction holder. Either the holder is missing or faulty, or the cable to the holder is loose or faulty.

E48.2 Suction holder related error messages.**E48.3 Suction holder related error messages.****E48.4 Suction holder related error messages.****E49.1 Suction holder PCB or its cable is faulty in branch 1.**

Either the holder is missing or faulty, or the cable to the holder is loose or faulty. The problem can be intermittent.

E49.2 Suction holder PCB or its cable is faulty in branch 2.

Either the holder is missing or faulty, or the cable to the holder is loose or faulty. The problem can be intermittent.

E50 Unidentified STCS jumper configuration.**E50.1 Water management system (WMS) must be set to Bottle water off -mode when starting suction cleaning.****E50.2 Suction disinfectant pump is not running.****31.4.7 Foot control related error messages****E51.1 Foot control related error messages.****E51.2 Foot control is not responding.**

Ensure that the foot control cable is properly attached to the unit. If it is, contact service.

E51.3 Foot control pedal was pressed down when dental unit was switched on.

Restart the unit without touching the foot control.

E51.4 Foot control pedal was not in home position when dental unit was switched on.

Restart the unit without touching the foot control.

E51.5 Foot control's chair control knob was not in home position when dental unit was switched on.

Restart the unit without touching the foot control.

E51.6 Foot control left knob is either stuck or active at power-up or after pedal use.**E51.7 Foot control right knob is either stuck or active at power-up or after pedal use.****E52 Foot control is of new type, update MCB software.**

The recently attached foot control is of a new type, or its software is not compatible with the MCB software. Update the MCB software. The new software on the MCB is also compatible with the older version(s) of the Prostyle Compact foot controls.

E52.1 Incompatible wireless foot control receiver software.

E52.2 Incompatible wireless foot control software.

E52.3 Incompatible foot control software.

E53 Foot control data error (cable short circuit).

E54.0 Foot control error.

These errors inform that the foot control calibration failed for some reason.

E54.1 Foot control EEPROM write failure.

E54.2 Foot control EEPROM read failure.

E54.3 Pedal too far from sensors, channel A.

E54.4 Pedal too far from sensors, channel B.

E54.5 Sensor plate is tilted too much to either side, checksum error.

E54.6 Sensor plate is too close to PCB, channel A.

E54.7 Sensor plate is too close to PCB, channel B.

E54.8 Foot control re-trigger error.

E54.9 Foot control calibration error.

E55 Wireless foot control connection lost

31.4.8 Operating light related error messages

E56 Operating light erroneously connected or short circuit in push button.

E57 Incompatible SingLED software

E58 Operating light bulb burned out.

Replace bulb.

31.4.9 Separator system related error messages

E59.1 Separator reports functional error.

The separator is signalling an error output (either Metasys (59.1) or Dürr (59.2)). Please check the separator documentation.

E59.2 Separator reports functional error.

Please check the separator documentation.

E60 Separator is not responding or separator cable is faulty.

E61 Separator is flooded with too much water.

E62 Newly attached separator is of new type and cannot be controlled by MCB.

E63.1 Water management system (WMS) seems to be installed, although it should not be (according to service mode).

E63.2 No Water management system (WMS) is installed, although it should be according to service mode.

31.4.10 Patient chair related error messages

E64 Lift motor position potentiometer or its cable is faulty or disconnected.

E65 Lift motor does not run or no signal from position potentiometer.

E65.1 Lift motor does not run. EmeStop relay PCB/cables or position sensor/ cable may be faulty.

E66 Lift motor or its position potentiometer cable has a wrong connection.

E67 Backrest position potentiometer or its cable is faulty or disconnected.

E68 Backrest motor does not run or no signal from position potentiometer.

E68.1 Backrest motor does not run. EmeStop relay PCB/ cables or position sensor/ cable may be faulty.

E69 Backrest motor or its position potentiometer cable has a wrong connection.

E70.1 Lift motor error.

Restart the unit. If error still occurs, contact service.

E70.2 Backrest motor error.

Restart the unit. If error still occurs, contact service.

31.4.11 MAIN CPU related error messages

E72.1 Program (Flash-EPROM) error. Main software is corrupted. Replace Flash-EPROM.

E72.2 Program (Flash-EPROM) error. Boot software is corrupted. Replace Flash-EPROM.

E72.3 Program (Flash-EPROM) error.

E72.4 Data transfer error while updating main PCB SW from control panel memory device.

E73.1 EEPROM error, CPU EEPROM erase/program failure, replace CPU.

E73.2 CPU configuration register contents are wrong, replace CPU.

E73.3 CPU EEPROM checksum error.

E73.4 CPU EEPROM checksum programmed. Replace CPU if error occurs often.

E75.1 CPU error, WD reset.

E75.2 Illegal OP-code.

E75.3 Illegal vector.

E75.6 Mains voltage failure.

E75.7 Clock monitor reset.

E76 Main PCB hardware test failed.

E76.1 Unknown PCB version. Software upgrade required.

E79 IMUX water pressure cannot be released during waterline cleaning cycle.

E79.1 IMUX water pressure rose during waterline cleaning cycle when pressure rise was not expected.

31.4.12 Headrest related error messages

E80.1 Motorised headrest is not found (according to service mode configuration).

E80.2 Motorised headrest is found, but is not set in service mode configuration.

E80.3 Headrest joystick (dentist side) stuck or cable broken.

E80.4 Headrest joystick (assistant side) stuck or cable broken.

E80.5 Motorised headrest motor A potentiometer or cable is faulty or

disconnected.

E80.6 Motorised headrest motor B potentiometer or cable is faulty or disconnected.

E80.7 Motorised headrest length potentiometer or cable is faulty or disconnected.

E81 Motorised headrest communication error (may be too old or wrong software or loose cables or short circuit).

E81.1 Motorised headrest communication error.

E82 Headrest software is incompatible with MCB software.

Headrest or MCB software should be upgraded.

E82.1 Headrest software is incompatible with MCB software.

Headrest or MCB software should be upgraded.

E82.2 Incompatible headrest software.

31.4.13 Water leak related error messages

E90 Water leak detected.

Main water valve is closed.

Water leak sensor has detected a leak. Check inside the unit for water leaks.

E90.1 Water leak detected. Water use allowed temporarily.

The use of water is temporarily allowed. Check for water leak inside dental unit.

31.4.14 Maintenance related errors

E91 Annual maintenance overdue.

Annual maintenance has not been performed within the specified period.

31.4.15 Software upgrade error messages

E99 Software upgrade failure.

Retry upgrade.

Make sure upgrade media is properly connected and contains a valid software package.

E99.1 MCB software upgrade failure.

Retry upgrade.

Software package may have been corrupt or hardware failure on MCB.

E99.2 IMUX software upgrade failure.

Retry upgrade.

Software package may have been corrupt or hardware failure. Check connection between MCB and IMUX.

E99.3 Control panel software upgrade failure.

Retry upgrade.

Software package may have been corrupt or hardware failure. Check connection between MCB and control panel.

E99.4 Operating light software upgrade failure.

Retry upgrade.

Software package may have been corrupt or hardware failure. Check connection between MCB and operating light.

E99.5 Motorised headrest software upgrade failure.

Retry upgrade.

Software package may have been corrupt or hardware failure. Check connection between MCB and headrest.

E99.6 Foot control software upgrade failure.

Retry upgrade.

Software package may have been corrupt or hardware failure. Check connection between MCB and foot control.

E99.7 Wireless foot control software upgrade failure.

Retry upgrade.

Software package may have been corrupt or hardware failure. Check connection between MCB and wireless foot control.

E99.8 Wireless foot control receiver software upgrade failure.

Retry upgrade.

Software package may have been corrupt or hardware failure. Check connection between MCB and wireless foot control receiver.

E99.9 PlanID reader software upgrade failure.

Retry upgrade.

Software package may have been corrupt or hardware failure. Check connection between MCB and PlanID reader.

31.4.16 Error messages generated by control panel

EP19.3 Control panel version mismatch.

Update the main PCB or control panel software.

EP19.5 Control panel software upgrade has failed or memory card is faulty.

Insert the updated software media into the control panel.

EP21.1 Control panel display is faulty.

Replace the control panel.

EP21.2 Control panel data error.

Ensure that the control panel data cable is properly connected.

EP21.5 Unable to read Main PCB software version.

The main PCB software may not support the control panel, or the control panel data cable is not properly connected.

EP21.6 Control panel software not installed or software error.

Insert the updated software media into the control panel.

EP21.7 Touch panel is not working.

32 Disposal

In order to reduce the environmental load over the product's entire life cycle, Planmeca products are designed to be as safe as possible to dispose of. Planmeca products fulfil the requirements of Directives RoHS, REACH and WEEE.

Disposal of obsolete units is the responsibility of the waste possessor. The risks involved and the necessary precautions must be taken into account when handling waste products.

Parts which can be recycled should always be taken to the appropriate processing centres, after the surfaces, waterlines and suction lines have been disinfected, and hazardous waste has been removed. All parts and components containing hazardous materials must be disposed of in accordance with waste legislation and instructions issued by the local environmental authorities.

The following parts contain hazardous waste:

- Amalgam separators in dental units, including filters and amalgam collector /deposit cup (amalgam)
- Suction systems. All components in contact with suction and drain flow paths are to be handled as potentially biohazardous.

Batteries must be disposed of in accordance with local waste legislation and instructions, and by following the requirements of EU battery regulation (EU) 2023/1542 as applicable.

The following parts contain batteries:

- Dental unit wireless foot control
- Circuit boards (may contain)

33 Technical information

33.1 Technical specifications

Original manufacturer	
PLANMECA Oy, Asentajankatu 6, 00880 Helsinki, FINLAND Phone: +358 20 7795 500, fax: +358 20 7795 555, www.planmeca.com	
Colours	
Painted parts:	RAL-9016
Upholstery colours:	Please consult your dealer for availability
Mechanical dimensions	
Installed:	(H x D x W) 1210 mm x 963 mm x 1990 mm (see template for details)
Weight	
150 kg (331 lbs)	
Maximum allowed load on patient seat	
Maximum allowed patient weight 185 kg (407 lbs) and accessories load of 15 kg (33 lbs)	
Environmental conditions	
Transportation conditions	
Temperatures:	-20°C to +60°C (-4°F to +140°F)
Relative humidity:	5% RH to 95% RH; non-condensing humidity
Air pressure:	700 hPa to 1060 hPa (10.2 psi to 15.4 psi)
Storage conditions	
Temperatures:	-5°C to +60°C (+23°F to +140°F)
Relative humidity:	5% RH to 95% RH; non-condensing humidity
Air pressure:	700 hPa to 1060 hPa (10.2 psi to 15.4 psi)
If the unit has been stored at temperatures below +10 °C (+50 °F) for more than a few hours, time must be allowed for the unit to reach room temperature in the original packing before connecting the unit to the mains voltage.	
Operating conditions	
Temperatures:	+15°C to +35°C (+59°F to +95°F)
Relative humidity:	5% RH to 95% RH; non-condensing humidity
Air pressure:	800 hPa to 1060 hPa (11.6 psi to 15.4 psi)
Altitude:	< 2000 m (less than 1.25 miles)
Mains voltage and frequency	
Mains voltage setting:	100V~ 115V~ 220-240V~
Mains frequency:	50 or 60 Hz
Fuse rating and type	

F1, F2 = Schurter 0001.1014 10A/250V/FAST ACTING/HIGH BR CAP. (100V, 115V)	
F1, F2 = Bussmann S501-10-R 10A 250V FAST ACTING/HIGH BR CAP. (100V, 115V)	
F1, F2 = Schurter 0001.1012 6.3A/250V/FAST ACTING/HIGH BR CAP. (220V – 240V)	
F1, F2 = Bussmann S501-6.3-R 6.3A 250V FAST ACTING/HIGH BR CAP. (220V- 240V)	
F3, F4 = 4A/250V/Fast act./High br. cap, Schurter 0001.1010 OR Bussmann S501-4-R	
F5 = 8A/250V/Fast act./High br. cap, Schurter 0001.1013 OR Bussmann S501-8-R	
F6 - F8 = 6.3A/250V/Fast act./High br. cap, Schurter 0001.1012 OR Bussmann S501-6.3-R	
Power consumption	
Idle unit:	≈ 60 VA (unit not in use, OP-light turned on)
Typical average:	≈ 350 VA (during patient treatment)
Maximum:	1450 VA (at maximum rated mains voltage, both chair motors running)
Electrical classification	
Class I	
Operation of chair lift and backrest motors	
Intermittent operation, ED 6%, 25 sec "ON", 400 sec. "OFF"	
Water supply	
Pressure range:	min. 300kPa (44 psi), max. 900 kPa (130 psi) In dental units with Planmeca WEK water disinfection system, the pressure range must be 300 - 600 kPa (44 – 87 psi). In dental units with Planmeca Patrol by BWT water filtration system, the pressure range must be 300 - 800 kPa (44 – 116 psi).
Flow rate:	≥ 4 l / min (maximum consumption at any instance)
Quality:	hardness; ≤ 8°dH
pH:	6.5 – 8.5
Maximum particle size:	< 100 µm
Maximum water conductivity:	2000 uS/cm
Connection:	1/4"

Backflow prevention:	<p>The water supply line must be equipped with a backflow prevention valve according to local requirements. E.g. in most European countries according to EN1717 standard, BA Type backflow preventer.</p> <p>In dental units with Planmeca WEK water disinfection system, a backflow prevention valve is not needed as the water supply line is separated from mains water with an AB type air gap.</p>
Air supply	
Pressure range:	min. 550 kPa (80 psi), max. 900 kPa (130 psi)
Flow rate:	≥ 55 litres / minute (maximum consumption at any instance)
Humidity:	dew point not greater than -20 °C at atmospheric pressure
Quality:	medical grade, dry and oil-free
Oil contamination:	max. 0.5 mg/m ³
Particulate contamination:	≤ 100 particles per cubic meter for 1 µm to 5 µm particle size
Connection:	1/4"
Water and air filters	
Water filter:	25 µm (internal), 5 µm (external suggested)
Air filter:	25 µm (internal)
<p>Replacement of water and air filters should be performed by qualified service technician according to the maintenance schedule.</p> <p>See section "Annual maintenance" on page 7.</p>	
Suction connection	
Vacuum:	≥ 150 mbar
Flow rate:	≥ 550 l / min
Connection:	Ø 50 / 46 mm
Type:	Medium volume
Class:	Wet or dry depending on installed options
Drain connection	
Capacity:	min. 10 l/min
Connection:	Ø 50 / 46 mm
Water and air quick-connectors (optional)	
Output pressure:	water 2.8 bar, air 5.5 bar (regulated internal water and air pressure)
Wireless foot control power supply (optional)	
<p>Power supply ingress protection less than IPX1. Foot control battery charging is not allowed while treating a patient.</p> <p>Type: MENB1010A0903F01, GSM40A09-P1L, MPU16A-104</p>	

Power supply ingress protection at least IPX1. Foot control battery charging is allowed while treating a patient.	
Type:	ME10A0903F01, ME20A0903F01
Wireless foot control (optional)	
Battery size:	AA, HR6
Battery type:	NiMH 1.2V, min 2000mAh, low self-discharge, UL-listed (USA, Canada only)
Planmeca ProSensor power supply (optional)	
Phihong Single Port Injector	
Type:	PSA16U-480 (POE)
Input voltage:	100-240 VAC (50-60 Hz)
Output voltage:	48VDC
Max. output current:	0.35 A
Insulation voltage	
Primary-secondary	3000VDC

Suction system cleaning, Planmeca approved suction disinfectant

Procedure	Dosage	Affect time
Suction system cleaning	Suction disinfectant concentration is 3.6%	Min. 2 minutes; can be adjusted

Planmeca approved disinfectants for the suction system are Dürr Orotol Plus and ORBI-Sept Evacuation System Disinfection Concentrate. For more information on these disinfectants, please refer to the manufacturer’s documentation.



33.2 Detachable parts

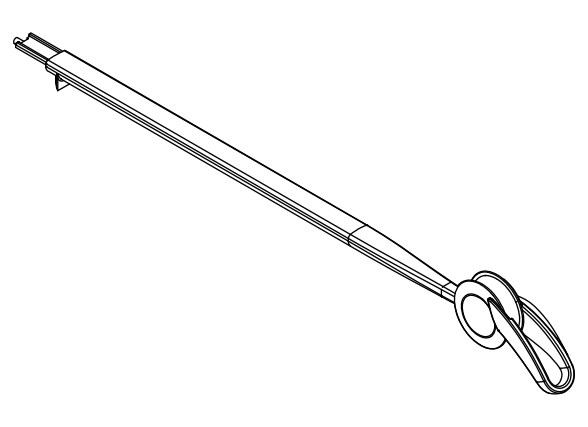

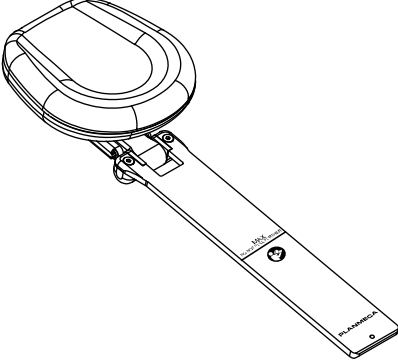
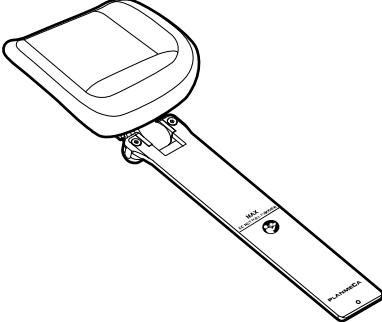
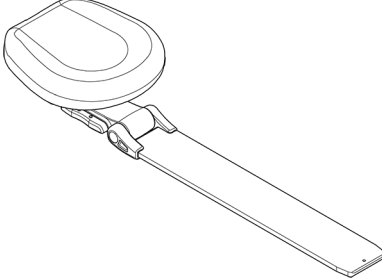
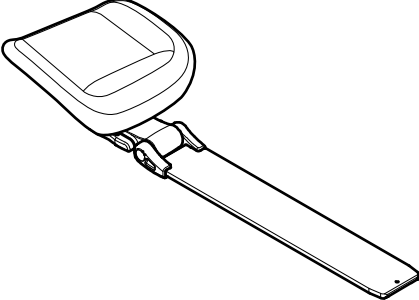
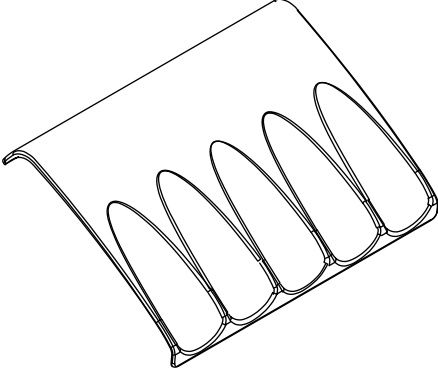

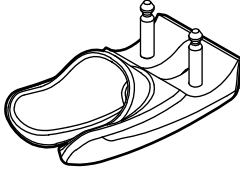
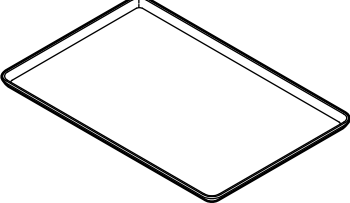
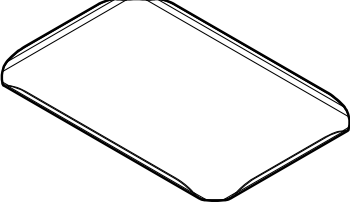
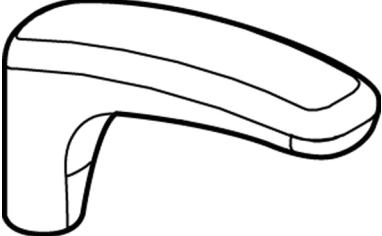
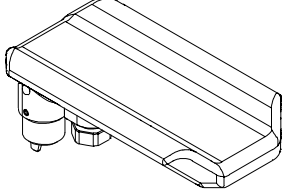
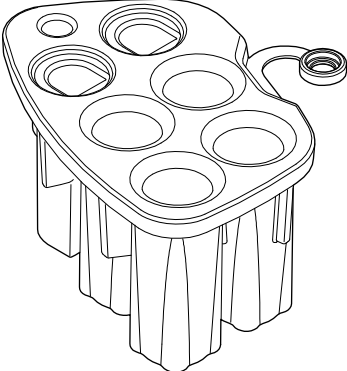
Use only genuine Planmeca parts.

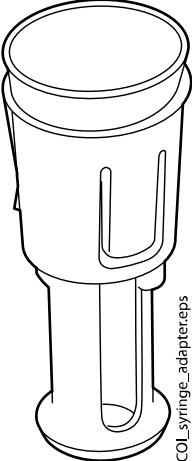
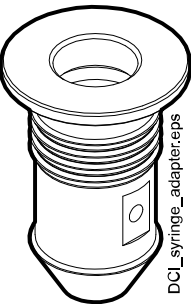
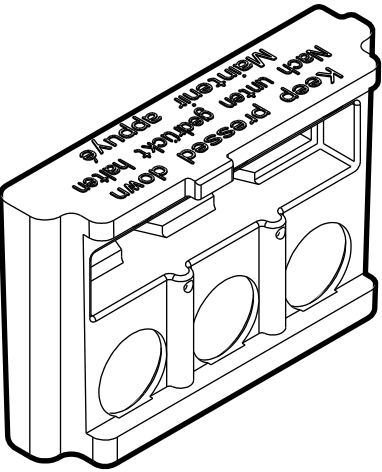

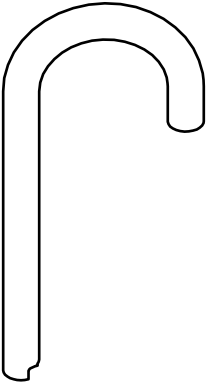
	<p>Balanced instrument arms</p>
---	---------------------------------

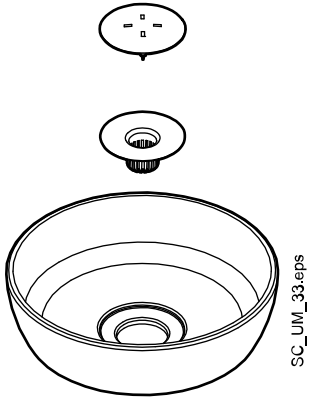
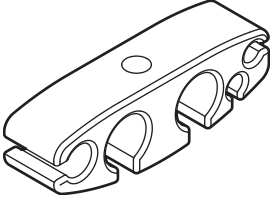



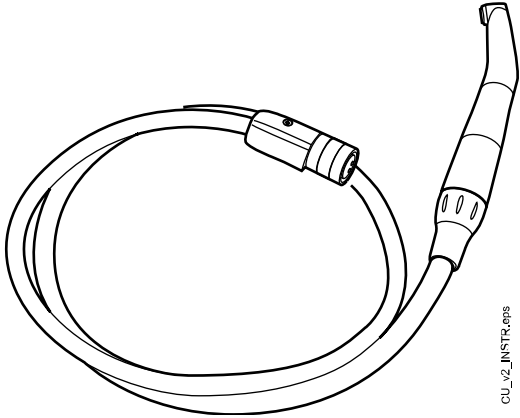
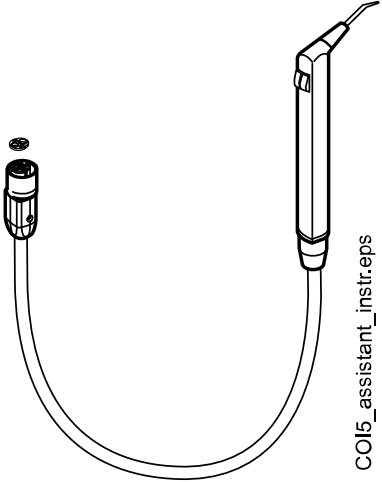

	Standard headrest with oval cushion
	Standard headrest with surgical cushion
	Swift headrest with oval cushion
	Swift headrest with surgical cushion
	Hygienic membrane

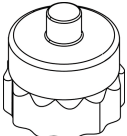
	<p>HT instrument holder</p>
	<p>Top tray (size 2)</p>
	<p>Quick connect tray (size 1 and 2)</p>
	<p>Armrests</p>
	<p>Surgical armrest (optional)</p>
	<p>Instrument flushing holder</p>

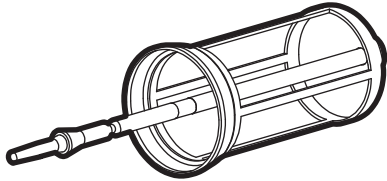
 <p>COL_syringe_adapter.eps</p>	Syringe adapter for Luzzani Minibright 6-way syringe
 <p>DCI_syringe_adapter.eps</p>	Syringe adapter for DCI syringe
 <p>Keep until further notice Nicht weiter abgeben pressed down</p>	Suction tube cleaning holder
	Suction tube cleaning holder plug
	Cup fill tube

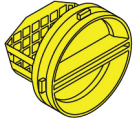
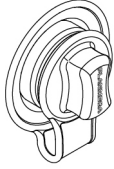
	<p>Bowl, filter and filter cap</p>
	<p>Tube holder</p>
	<p>Suction tubes</p>
	<p>Suction handpiece assembly with tilting head (Planmeca) and bushing</p>
	<p>Suction handpiece assembly with Billund heads</p>
	<p>Suction handpiece assembly with Dürr heads</p>

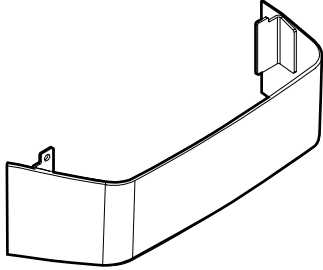
 <p style="text-align: right; font-size: small;">CU_v2 INSTR.eps</p>	<p>Dentist's instruments and hoses</p>
 <p style="text-align: right; font-size: small;">CO15_assistant_instr.eps</p>	<p>Assistant's instruments and hoses</p>
	<p>Sterile water hoses</p>
	<p>Planmeca Patrol filter (optional)</p>
	<p>Planmeca Patrol blind cap (optional)</p>

	Disposable filters
	Filter cap
	Dürr spittoon bowl valve 7560-700-57 CAP
	Container cap yellow (NCS S 0580-Y)
	Dürr deposit cup
	Operating light handle
	Side cover plate for cuspidor
	Foot cover

33.3 Applied parts

Applied parts are parts of the dental unit that in normal treatment situations come into contact with the patient.

The applied parts of this dental unit include the instruments and their handpieces, the patient chair with upholstery, and the armrests.

33.4 Instrument classifications

The electrical classification of the instrument is marked on the instrument hose either as B or BF. If there is no marking, no electricity flows through the instrument.



Type B



Type BF

The following lists the instruments that are available for the Planmeca dental unit and their electrical classification type.

Instrument classifications

Instrument	Type
DCI autoclavable 3-way syringe	B
Luzzani Ergo 3-way syringe	B
Luzzani Minibright 6-way syringe with LED	B
PM fibre optic turbine hose S	B
Bien-Air MCX brushless micromotor with LED	B
Bien-Air MX2 Plus brushless micromotor with LED	B
Bien-Air MX-i LED implantology micromotor	B
KaVo KL703 LED micromotor	B
KaVo KL703 LED with endo micromotor	B
SycoTec SLM-E Typ 810 brushless micromotor with LED	B
Morita TORX micromotor	B
Planmeca Piezon LED (EMS) scaler	B
LM-ProPower Ultra scaler	B
LM-ProPower UltraLED scaler	B
Satelec Newtron scaler	B
Satelec Newtron LED scaler	B
Planmeca Lumion Plus LED polymerisation light	B
Planmeca Somia USB intraoral camera	BF
KaVo DIAGNOcam Vision Full HD intraoral camera	B
Planmeca Emerald S intraoral scanner	B

33.5 Dimensions

33.5.1 Positioning of patient, dentist and assistant

The following picture shows an example of how to position the dentist and assistant during four-handed treatment.

The patient must always be positioned in the patient chair, with arms and legs resting on the upholstery. The dentist and assistant can move within the areas marked in the picture below.

NOTE

The following picture is an example only and presents one possible scenario. The actual positioning of dentist and assistant depends on the used working method, treatment situation, region etc. and can therefore not be explicitly stated in this manual.

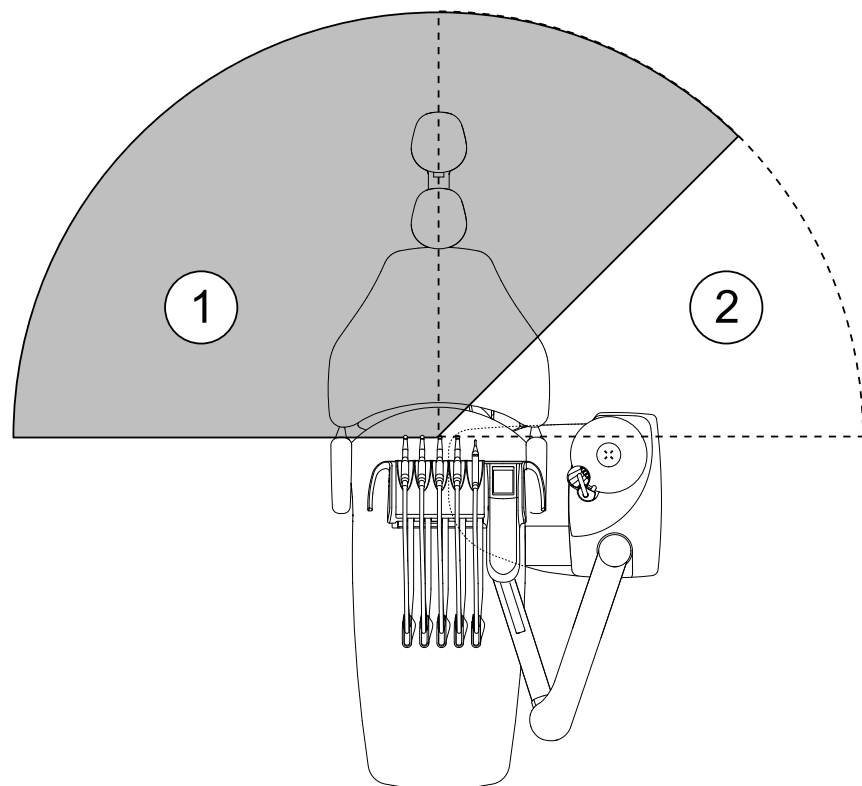

1. Dentist's area
2. Assistant's area

33.5.2 Patient area

The patient area is 1.5 m (59.1") in each direction from the dental unit.

The external PC, its keyboard and mouse, as well as the Planmeca ProSensor power supply and the Planmeca ProX generator assembly must be located outside the patient area. The dentist, assistant and patient must not touch the equipment outside the patient area during treatment.

CAUTION

Use only Planmeca specified devices inside the patient area.

CAUTION

The floor of the patient area must be dry.

NOTE

Connect only Planmeca specified devices to the dental unit.

NOTE

The external PC must be protectively earthed and IEC 60950 or IEC 62368 -approved (CE marked).

NOTE

The monitor must fulfil IEC 60601-1 Ed 3.1 requirements.

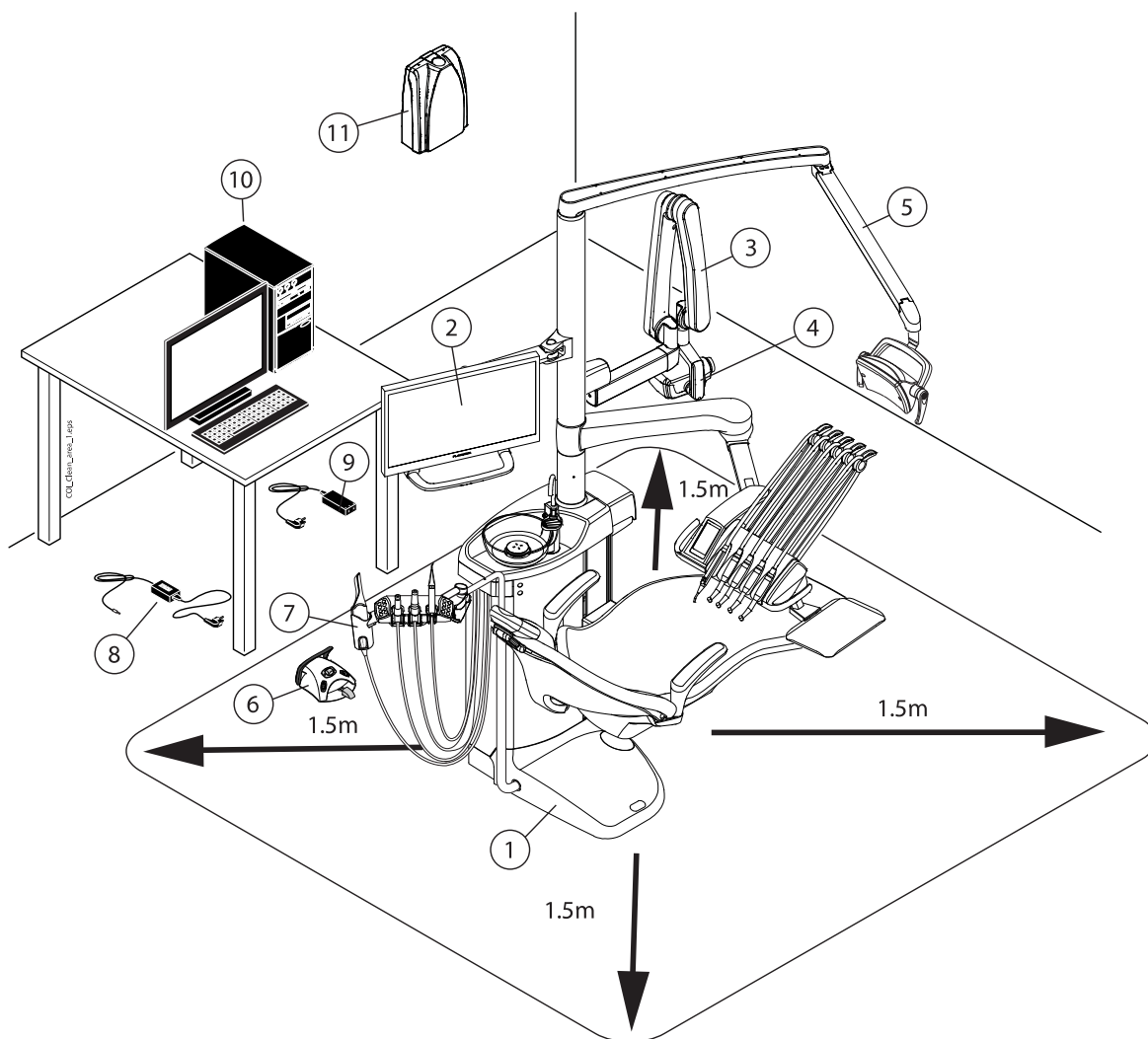

Inside patient area:	Outside patient area:
1. Dental unit	8. Foot control battery charger *
2. Planmeca monitor	9. Planmeca ProSensor PoE port and power cable
3. Planmeca ProX X-ray tube head and arm assembly	10. External PC
4. Planmeca ProSensor control box	11. Planmeca ProX generator assembly
5. Planmeca operating light	
6. Foot control. Use only IEC 60601-1 approved power source supplied by Planmeca	
7. Planmeca intraoral scanner	

* If the foot control power supply is of type ME10A0903F01 or ME20A0903F01, the battery can be charged while treating a patient and thus used inside the patient area. Check the label on the power supply to ensure whether the battery can be charged while treating a patient.

33.5.3 Over-the-patient delivery with balanced instrument arms

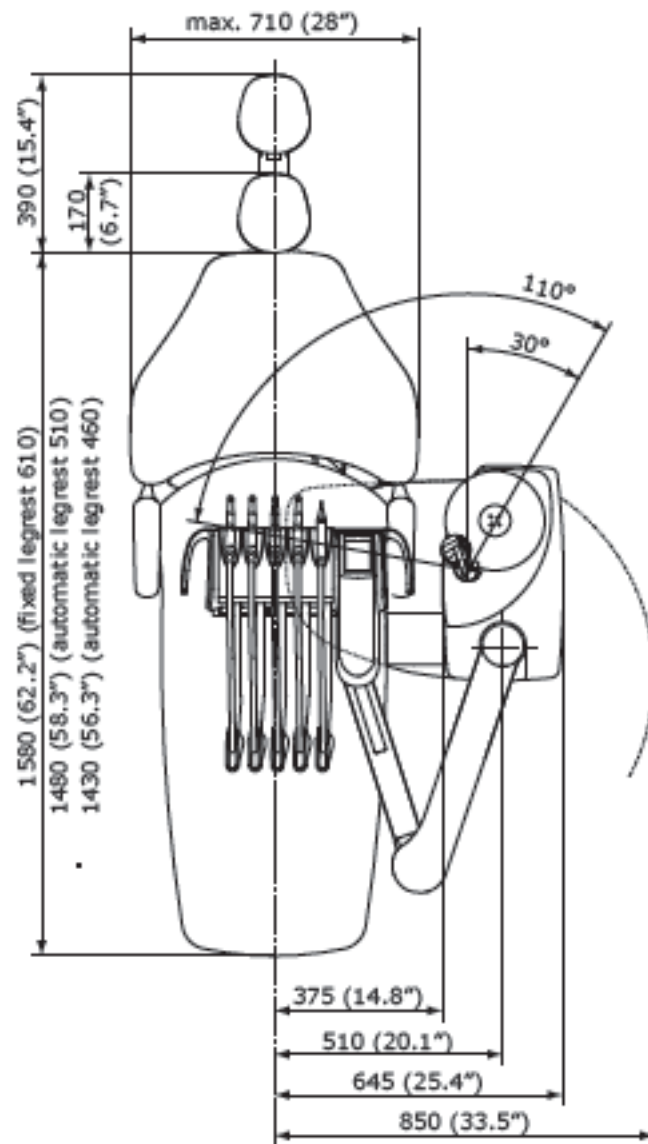

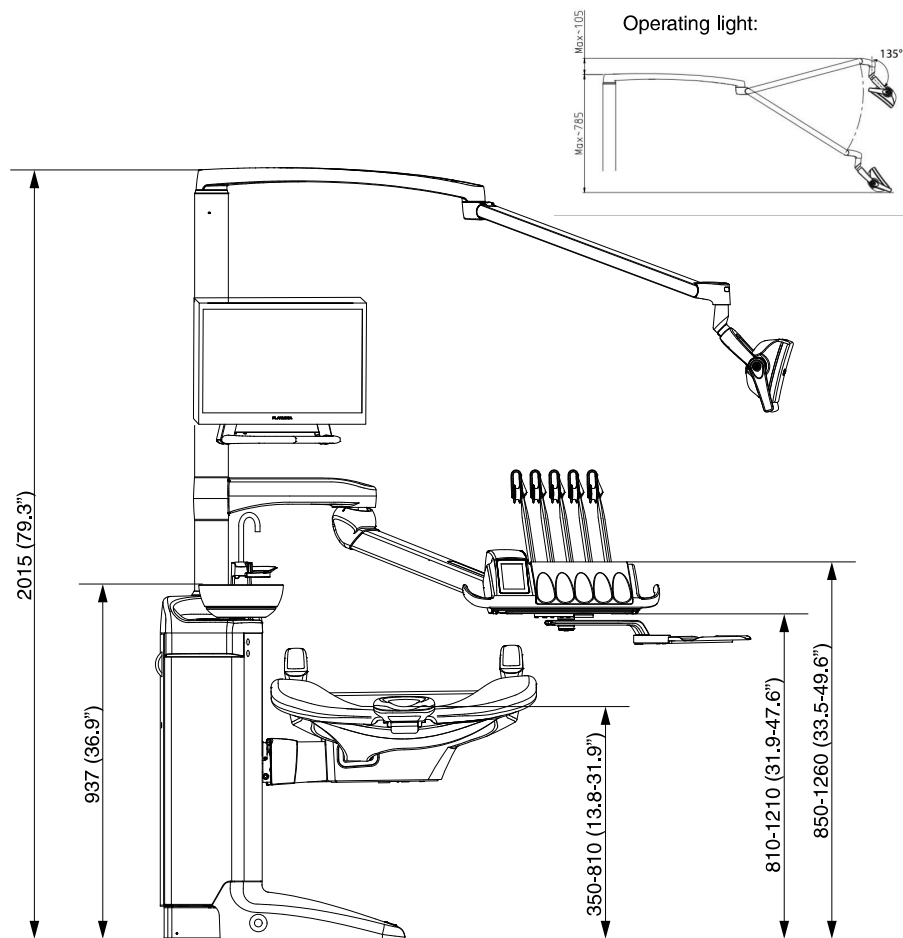

33.5.4 Over-the-patient delivery with hanging-tube instruments

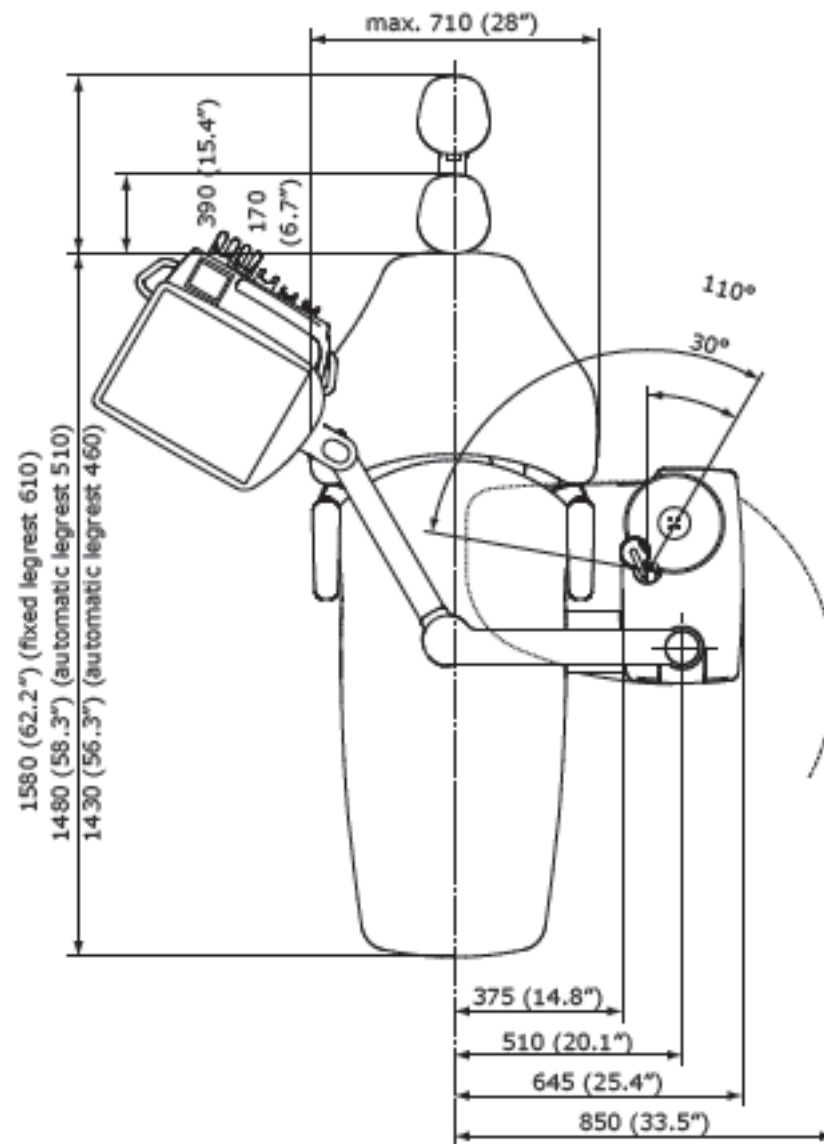

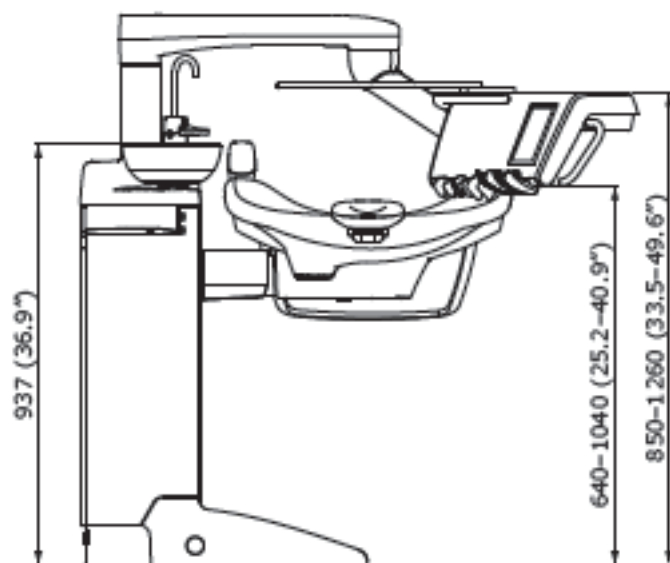

33.5.5 Side delivery with hanging-tube instruments

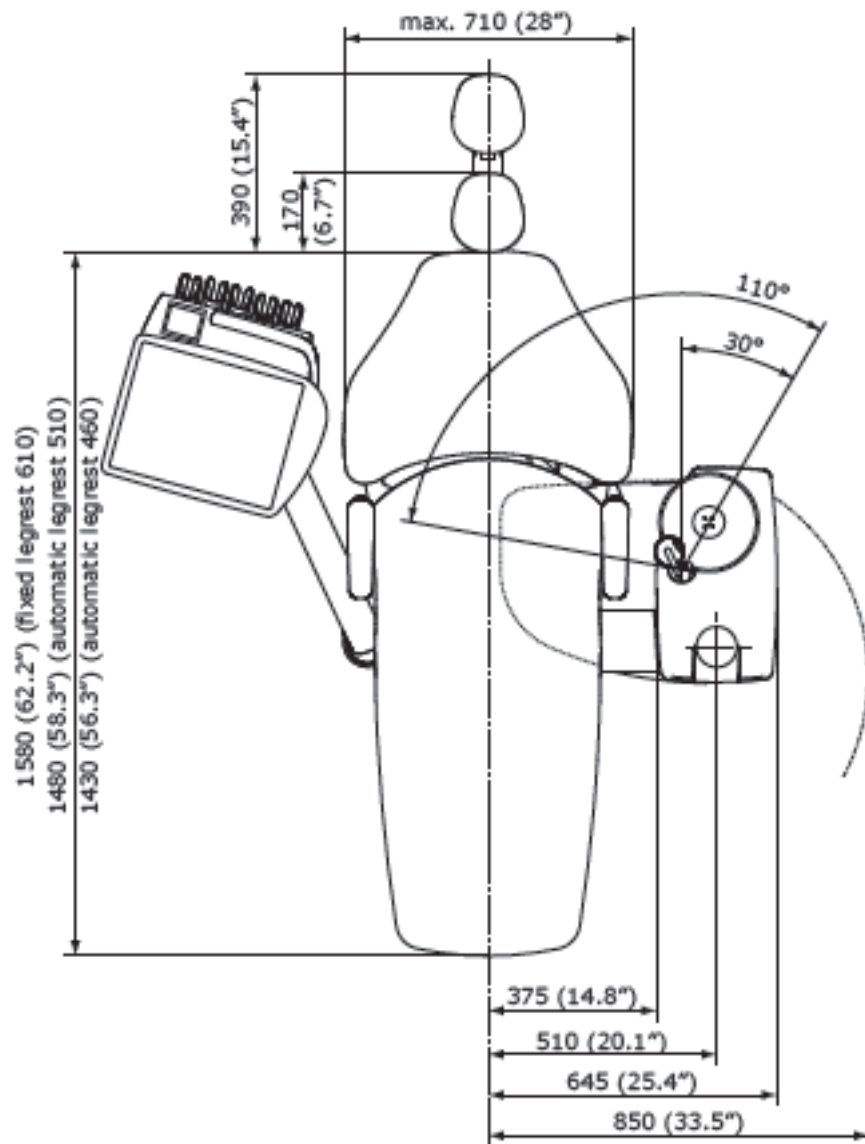

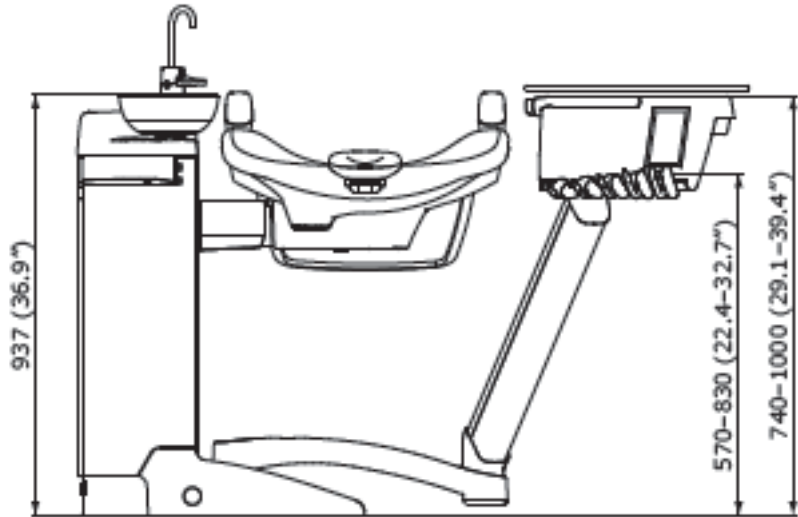

33.6 Planmeca Compact i dental unit water consumption

Part	Water consumption
Bowl	The flow rate is approx. 2.5 litres (0.66 gallons) per minute. The flow rate can be configured.
Cup fill	The cup filling is adjusted for the size of cup you use.
Syringe	The flow rate is approx. 0.1 litres (0.03 gallons) per minute.
Handpieces	The flow rate is approx. 0.05 litres (0.01 gallons) per minute.
Suction system	The flow rate is approx. 0.4 litres (0.11 gallons) / minute when the suction is on, and the amount depends on which suction system is used in the dental unit. The water flow keeps the suction system clean when in use.
Suction system cleaning cycle	Cleaning is done once a day and uses 2.5 litres (0.66 gallons) of water.

34 Planmeca as EU importer

Planmeca is the EU importer for the following manufacturers:

E.M.S Electro Medical Systems S.A

Rue Vuarpilliere 31, CH-1260 Nyon, Switzerland

EU authorised representative:

EMS France SARL

Route de Pontarlier 32, 39460 Foncine le Haut, France

J. Morita MFG. Corp.

680 Higashihama Minami-cho Fushimi-ku Kyoto 612-8533, Japan

EU authorised representative:

Medical Technology Promedt Consulting GmbH

Altenhofstrasse 80, 66386 St. Ingbert, Germany

Dental Components, LLC dba DCI International

305 North Springbrook Rd Newberg, Oregon 97132, USA

EU authorised representative:

Dental Components Europe (DCE)

56 Bis Avenue de la Lanterne, 06200 Nice, France

35 Certifications

35.1 CE

Hereby, Planmeca Oy declares that the radio equipment type PlanID™ is in compliance with Directive 2014/53/EU.

The full text of the EU declaration of conformity is available upon request.

35.2 EU Declaration of Conformity for PlanID RFID-reader

Hereby, Planmeca Oy declares that the radio equipment type PlanID™ is in compliance with Directive 2014/53/EU.

The full text of the EU declaration of conformity is available upon request.

35.3 EAC Declaration of Conformity for PlanID RFID-reader

This device has been tested to comply with the applicable standards. The full text of the EAC declaration of conformity is available upon request.

If an operational failure of the device is detected, consult your local Planmeca dealer for assistance.

For date of manufacture of the device please see type label on device.

35.4 FCC Class B Notice for wireless foot control

This device complies with Part 15 of the FCC Rules. Operation is subject to the following two conditions:

1. This device may not cause harmful interference.
2. This device must accept any interference received, including interference that may cause undesired operation.

Note: This equipment has been tested and found to comply with the limits for a Class B digital device, pursuant to Part 15 of the FCC Rules. These limits are designed to provide reasonable protection against harmful interference in a residential installation. This equipment generates, uses and can radiate radio frequency energy and, if not installed and used in accordance with the instructions, may cause harmful interference to radio communications. However, there is no guarantee that interference will not occur in a particular installation. If this equipment does cause harmful interference to radio or television reception, which can be determined by turning the equipment off and on, the user is encouraged to try to correct the interference by one or more of the following measures:

- Reorient or relocate the receiving antenna.
- Increase the separation between the equipment and receiver.
- Connect the equipment into an outlet on a circuit different from that to which the receiver is connected.
- Consult the dealer or an experienced radio/television technician for help.

Modifications: Any modifications made to this device that are not approved by Planmeca may void the authority granted to the user by the FCC to operate this equipment.

35.5 FCC Class B Notice for PlanID RFID-reader

This device complies with Part 15 of the FCC Rules. Operation is subject to the following two conditions:

1. This device may not cause harmful interference.
2. This device must accept any interference received, including interference that may cause undesired operation.

Note: This equipment has been tested and found to comply with the limits for a Class B digital device, pursuant to Part 15 of the FCC Rules. These limits are designed to provide reasonable protection against harmful interference in a residential installation. This equipment generates, uses and can radiate radio frequency energy and, if not installed and used in accordance with the instructions, may cause harmful interference to radio communications. However, there is no guarantee that interference will not occur in a particular installation. If this equipment does cause harmful interference to radio or television reception, which can be determined by turning the equipment off and on, the user is encouraged to try to correct the interference by one or more of the following measures:

- Reorient or relocate the receiving antenna.
- Increase the separation between the equipment and receiver.
- Connect the equipment into an outlet on a circuit different from that to which the receiver is connected.
- Consult the dealer or an experienced radio/television technician for help.

Modifications: Any modifications made to this device that are not approved by Planmeca may void the authority granted to the user by the FCC to operate this equipment.

35.6 Industry Canada (IC) Compliance Statement

This device complies with Industry Canada licence-exempt RSS standard(s). Operation is subject to the following two conditions:

(1) this device may not cause interference, and (2) this device must accept any interference, including interference that may cause undesired operation of the device.

35.7 Industrie Canada (IC) Déclaration de conformité

Le présent appareil est conforme aux CNR d'Industrie Canada applicables aux appareils radio exempts de licence. L'exploitation est autorisée aux deux conditions suivantes:

(1) l'appareil ne doit pas produire de brouillage, et (2) l'utilisateur de l'appareil doit accepter tout brouillage radioélectrique subi, même si le brouillage est susceptible d'en compromettre le fonctionnement.

35.8 RF Exposure

This device has been tested for compliance with FCC RF exposure limits in a portable configuration. At least 15 cm of separation distance between the PlanID device and the user's body must be maintained at all times. This device must not be used with any other antenna or transmitter that has not been approved to operate in conjunction with this device.

PLANMECA

Planmeca Oy | Asentajankatu 6 | 00880 Helsinki | Finland

tel. +358 20 7795 500 | fax +358 20 7795 555 | sales@planmeca.com | www.planmeca.com

